

NITTO KOHKI AUTO HINGES

FLAG TYPE



AUTO HINGE

Flag type series (Table of models with specifications)

	Model number		Type of door	Door size applicable (mm)			Door weight (kg) (Max)	Closing force (N·m)	Stop mechanics	Stop angle	Max. Opening angle	Color										
	Right hand opening	Left hand opening		W (Max)	H (Max)	D (Min)																
P.4	300 Series Empty hinge	311S (Available for both right and left)	Wood, aluminum (Indoor use)	800	2000	30	30	5.0	○	85°~180°	180° Left or right one side opening	Silver Bronze Ivory Gold										
		310 (Available for both right and left)						—	—	—												
P.5	1000 Series	1111R	Wooden door Aluminum door Light steel door	850	2000	30	35	7.9	—	—	180° Left or right one side opening	Silver Bronze Silver Bronze										
		1111SR							1111SL	○			85°									
		1121R							1121L	—			—									
		1121SR							1121SL	○			85°									
P.6	1000 Series	1211R	Wooden door Aluminum door Light steel door	850	2000	30	35	7.9	—	—	180° Left or right one side opening	Silver Bronze Silver Bronze										
		1211SR							1211SL	○			85°									
		1221R							1221L	—			—									
		1221SR							1221SL	○			85°									
P.5	1000 Series	1110R	Wooden door Aluminum door Light steel door	850	2000	30	35	7.9	—	—	180° Left or right one side opening	Silver Bronze Silver Bronze										
		1110L							1110L	—			—									
		1120R							1120L	—			—									
		1120L							1120L	—			—									
P.6	1000 Series	1210R	Wooden door Aluminum door Light steel door	850	2000	30	35	7.9	—	—	180° Left or right one side opening	Silver Bronze Silver Bronze										
		1210L							1210L	—			—									
		1220R							1220L	—			—									
		1220L							1220L	—			—									
P.7	100 Series	112R	Wooden door Light steel door (122T for steel frame)	900	2100	30	40	10.0	—	—	180° Left or right one side opening	Silver or Bronze Silver Silver or Bronze Silver										
		112SR							112SL	○			85° and 150°									
		122R-T							122L-T	—			—									
P.8		100 Series	122SR-T	Wooden door Light steel door (122T for steel frame)	900	2100	30	40	10.0	○			85° and 150°	180° Left or right one side opening	Silver or Bronze Silver Silver or Bronze Silver							
			113R							113L			—			—						
			113SR							113SL			○			85° and 150°						
P.9			100 Series	113R TRISET	Wooden door Aluminum door	1000	2200	30	80	20.0			—			—	180° Left or right one side opening	Silver or Bronze Silver Silver or Bronze Silver				
				113SR TRISET									113SL TRISET			○			85° and 150°			
				122R-AT									122L-AT			—			—			
P.10				100 Series	122SR-AT	Wooden door Light steel door (122T for steel frame)	900	2100	30	40			10.0			○			85° and 150°	180° Left or right one side opening	Silver or Bronze Silver Silver or Bronze Silver	
					132R											132L			—			—
					132SR											132SL			○			85° and 150°
P.11	100 Series				143R-T	Steel door	900	2100	30	60	15.0	—	—			180° Left or right one side opening			Silver or Bronze Silver Silver or Bronze Silver			
					143SR-T							143SL-T	○									85° and 150°
					143R-AT							143L-AT	—									—
P.12		100 Series			143SR-AT	Steel door	900	2100	30	60	15.0	○	85° and 150°	180° Left or right one side opening	Silver or Bronze Silver Silver or Bronze Silver							
					110R							110L	—									—
					120R-T							120L-T	—									—
P.7			100 Series		120R-AT	Wooden door Light steel door (120T for steel frame)	900	2100	30	40	10.0	—	—				180° Left or right one side opening	Silver or Bronze Silver Silver or Bronze Silver				
					130R							130L	—									—
					140R-T							140L-T	—									—
P.8				100 Series	140R-AT	Aluminum door Light steel door Partition door	900	2100	30	60	15.0	○	85° and 150°							180° Left or right one side opening	Silver or Bronze Silver Silver or Bronze Silver	
					140R-T							140L-T	—									—
					244R-T							244L-T	—									—
P.11	100 Series				244SR-T	Steel door	1200	2100	40	120	22.6	○	85° and 150°			180° Left or right one side opening			Silver Silver Silver or Bronze Silver			
					240R-T							240L-T	—									—
					240R-T							240L-T	—									—

	Model number		Type of door	Door size applicable (mm)			Door weight (kg) (Max)	Closing force (N-m)	Stop mechanics	Stop angle	Max. Opening angle	Color								
	Right hand opening	Left hand opening		W (Max)	H (Max)	D (Min)														
P.17	700 Series	733R	733L	Aluminum door Stainless door Steel door	900	2100	40	120	15.0	—	—	180° Left or right one side opening	Silver							
		733SR	733SL							○	85° and 150°									
		Empty hinge 730R	730L							—	—									
P.19	PC Series	113R-PC	113L-PC	Wooden door Aluminum door Light steel door	900	2100	30	40	15.0	—	—	180° Left or right one side opening	Silver							
113SR-PC		113SL-PC	○							85° and 150°										
P.20		133R-PC	133L-PC	Aluminum door Light steel door						—	—			—	—	—	—	—	—	—
P.21		133SR-PC	133SL-PC																	
P.21		143R-T-PC	143L-T-PC	Steel door						1200	2100			40	120	22.6	—	—	180° Left or right one side opening	Silver
P.22		143SR-T-PC	143SL-T-PC														○	85° and 150°		
P.22		244R-T-PC	244L-T-PC														—	—		
P.22		244SR-T-PC	244SL-T-PC														○	85° and 150°		
P.19	Empty hinge	110R-PC	110L-PC	Wooden door Light steel door	900	2100	30	40	—	—	—	—								
P.20		130R-PC	130L-PC	Aluminum door Light steel door									60							
P.21		140R-T-PC	140L-T-PC	Steel door										900	2100	40	120			
P.22		240R-T-PC	240L-T-PC																	
P.23	153 Series	NK153R	NK153L	Glass door	900	2100	8 10 12	60	15.0	—	—	180° Left or right one side opening	Silver							
P.24		NK153SR	NK153SL							○	85° and 150°									
		NK153R TRISET	NK153L TRISET							—	—									
		NK153SR TRISET	NK153SL TRISET							○	85° and 150°									
	Empty hinge	NK150R	NK150L		1000	2200	8 / 10 / 12	80	—	—										

- Each article is a combination of a spring hinge and a damper hinge (except for empty hinges).
- For opening orientation, each article designation gives an R to represent right-handed opening, and an L to represent left-handed opening. The opening orientation of the 300 series is for both right- and left-handed opening.
- The "S" in an article designation means that the product has a stop (with an internal stop mechanism).
- Every model with a -T or an -AT at the end of its article designation has a tap hole (M6) for installing it on a hinge flap. Nitto Kohki is ready to produce products of the same model but without such tap holes. (Examples: with tap hole, 143R-T; without tap hole, 143-R)
- The 300 and 1000 series with empty hinges are in packages of two pairs each, and the 100, 200, 700 and PC series come in packages of one pair each.

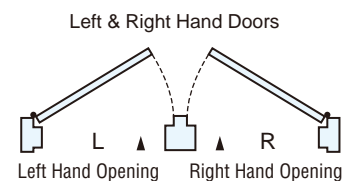

Comfort in a widening range of applications

Nitto Kohki's Auto Hinges of the flag type

They match all kinds of doors and make their images stand out beautifully.

Flag type

300, 1000, 100, and 200 series

Simple design

The hinges double as door closers, thus giving the doors a neat-looking finish. Their simple and beautiful designs match all kinds of doors.

A wide range of uses

They can also be used on arch doors that are not readily compatible with other door closers and doors with no head rails.

Sufficient door-closing power

The 100 and 200 series incorporate two springs (weak and strong) and a switching mechanism (clutch) for them, thus giving a small but sufficient door-closing power.

An internal stop mechanism

The 300 series comes with an automatic mechanism for stopping closings at 85° to 180° (free stops), the 1000 series at 85°, and the 100 and 200 series at 85° and 150°.

Simple adjustment of closing speed

The speed can easily be adjusted with the mere use of a screwdriver.

Easy to install

These hinges are installed in exactly the same manner as conventional flag-type hinges. They do not require much labor. They are easy to handle.

Outstanding durability

They are so structured as to undergo little friction, thus achieving outstanding durability.

Table of applicable doors

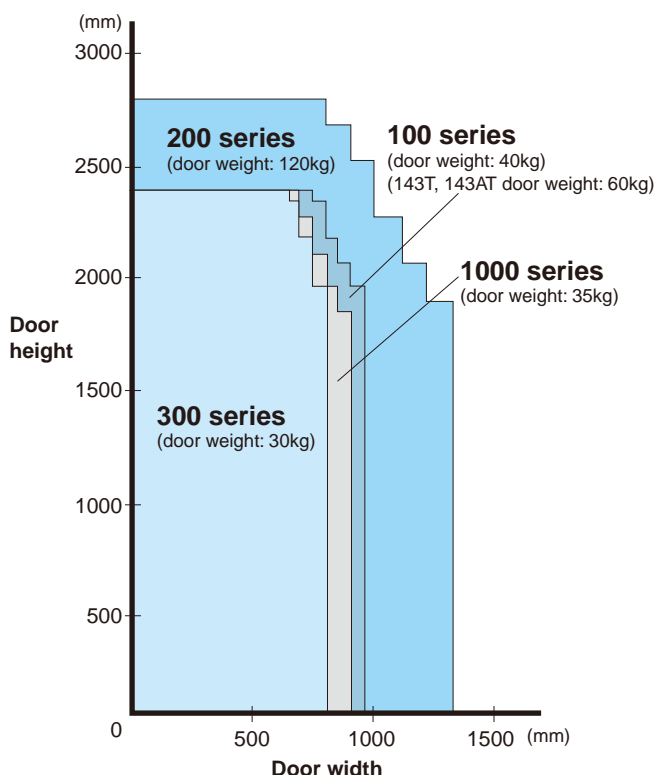

Spring hinge

(with an internal self-closing and stop mechanism)

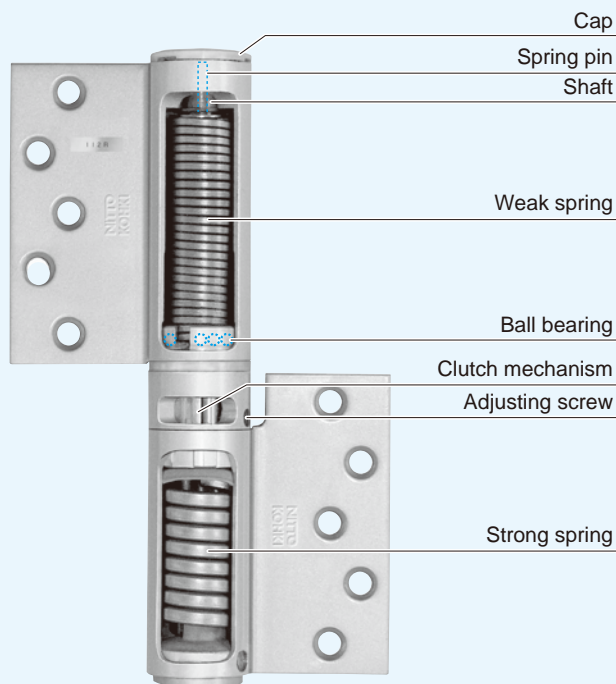

Damper hinge

(with an internal control mechanism for closing speed)

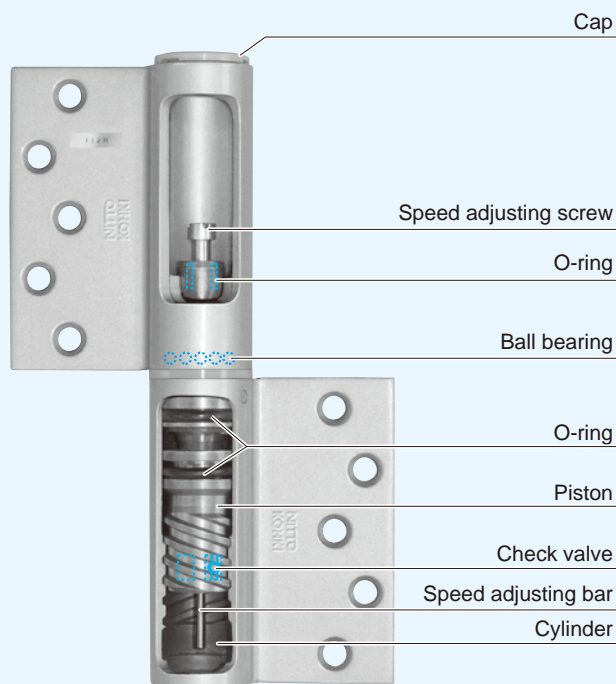

- Each model consists of a spring hinge and a damper hinge.
- This diagram represents the structure of the 100 series.

Model Number		Door Size Applicable (mm)			Door Weight (kg)	Closing Force (N-m)	Stop Mechanism	Location of Stop	Max. Opening Angle	Surface Color
		W	H	D						
311S		800(Max)	2000(Max)	30(Min)	30(Max)	5.0	○	85°~180°	180° Left or Right One-side Opening	Silver Bronze ivory gold
Empty Hinge	310					—	—	—		

● Available for both right-opening and left-opening doors.



EXTERNAL DIMENSIONS

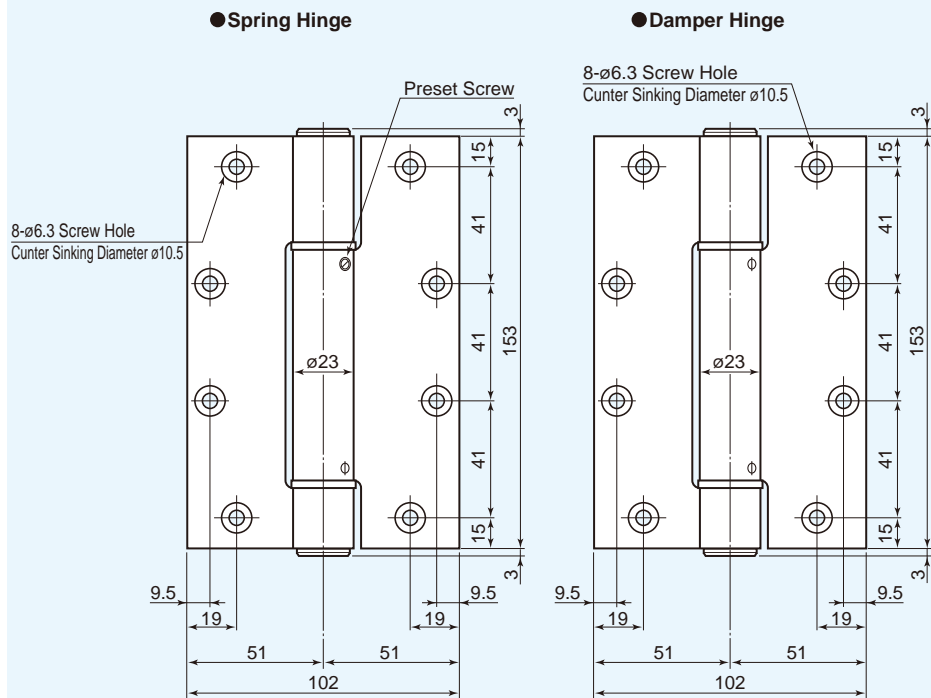

Remarks

1. Surface treatment is by a baked coating of melamine resin.
2. When using them on wooden doors, use lauan or harder wood.
3. The tapping screws furnished with the products and designed specifically for installation are 25mm long. If the frame is wooden, use a frame at least 25mm thick. If an aluminum, lightweight steel door is involved, use steel screws (flat screws M5).
4. Allow at least 3mm of space between outer edge of door and frame.

FITTING DIAGRAMS

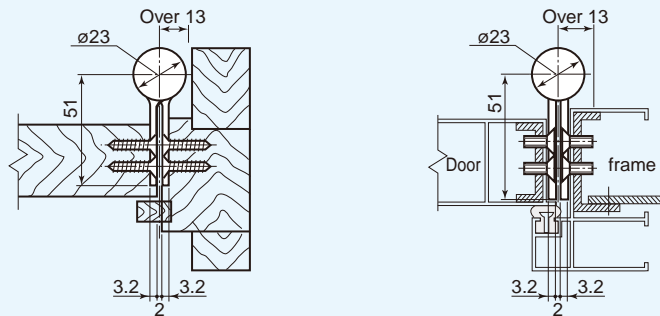

Wooden Doors

Aluminium Doors

1000series Model 1100

Model Number		Door Size Applicable(mm)			Door Weight (kg)	Closing Force (N-m)	Stop Mechanism	Location of Stop	Max. Opening Angle	Surface Color
Right hand door	Left hand door	W	H	D						
1111R	1111L	850(Max)	2000(Max)	30(Min)	35(Max)	7.9	—	85°	180° Left or Right One-side Opening	Silver
1111SR	1111SL									Bronze
1121R	1121L									Bronze
1121SR	1121SL									Bronze
Empty Hinge	1110R	1110L				—	—	—		Silver
	1120R	1120L								Bronze



EXTERNAL DIMENSIONS Left Hand Door

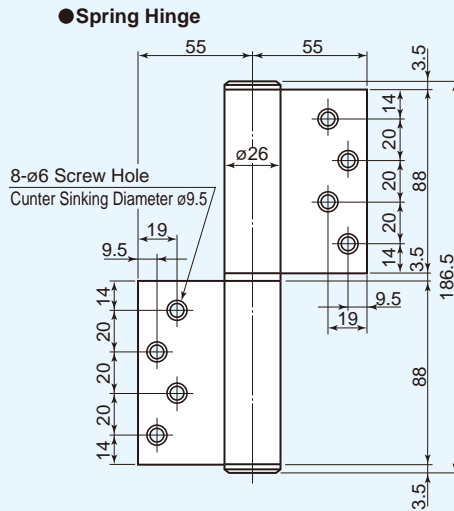

Right Hand Door

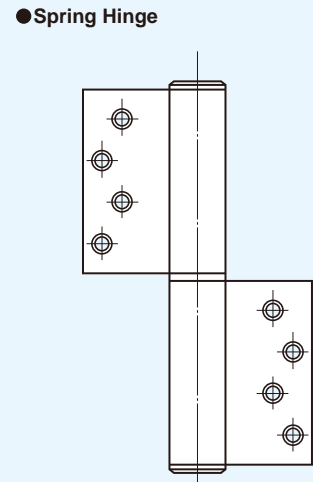

● Damper Hinge

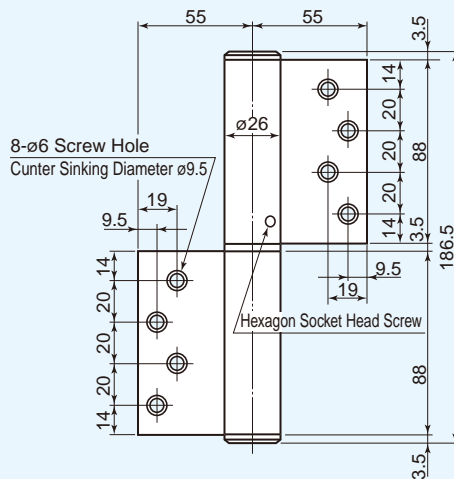

● Damper Hinge

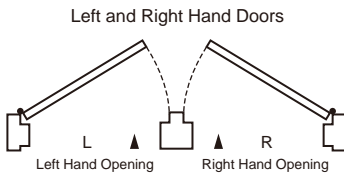
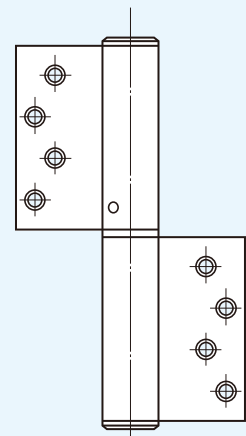

Remarks

1. The door and frame materials to which the hinge is to be fitted should be of hard wood such as lauan or harder.
2. Because the attached screws for fitting are 25mm long, the thickness of the frame should be over 25mm.
3. Allow at least 5mm of space between outer edge of door and frame.
4. Body material : Aluminum
Surface treatment :
Silver(anodic oxide coating)
Bronze(baked epoxy resin coating)

FITTING DIAGRAMS

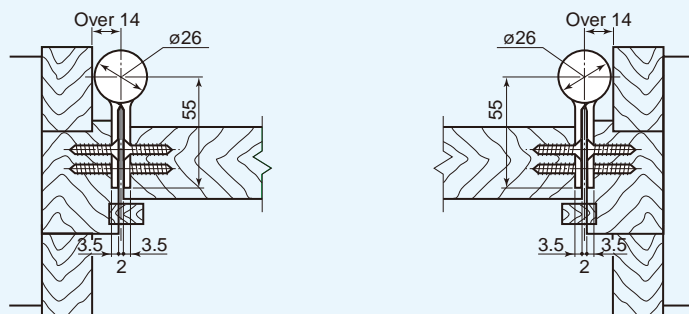

Model Number		Door Size Applicable(mm)			Door Weight (kg)	Closing Force (N-m)	Stop Mechanism	Location of Stop	Max. Opening Angle	Surface Color
Right hand door	Left hand door	W	H	D						
1211R	1211L	850(Max)	2000(Max)	30(Min)	35(Max)	7.9	—	85°	180° Left or Right One-side Opening	Silver
1211SR	1211SL									Bronze
1221R	1221L									Silver
1221SR	1221SL									Bronze
Empty Hinge	1210R	1210L				—	—	—		Silver
	1220R	1220L								Bronze



EXTERNAL DIMENSIONS

Left Hand Door

● Spring Hinge

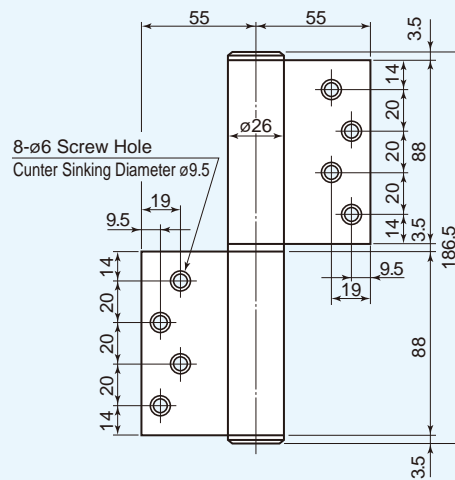

Right Hand Door

● Spring Hinge

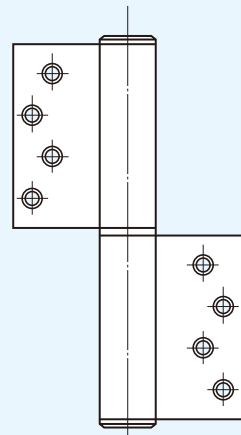

● Damper Hinge

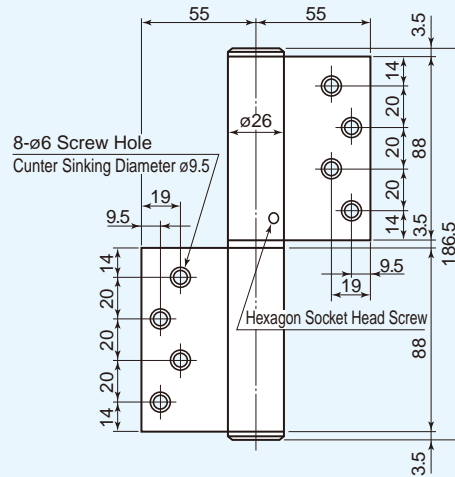

● Damper Hinge

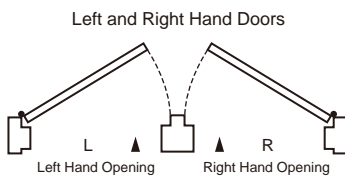
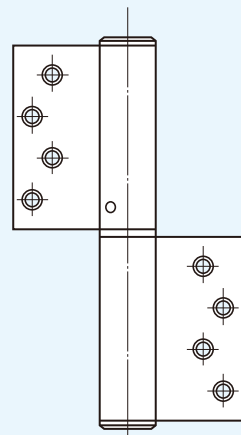

Remarks

1. For the wing fitting place on the door and frame, a steel plate of over 2.3mm thickness and 300mm length must be used as a reinforcing material.
2. Use the screws included in package for installation.
3. Allow at least 5mm of space between outer edge of door and frame.
4. Body material : Aluminum
Surface treatment :
Silver(anodic oxide coating)
Bronze(baked epoxy resin coating)

FITTING DIAGRAMS

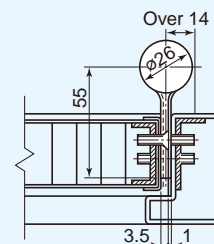
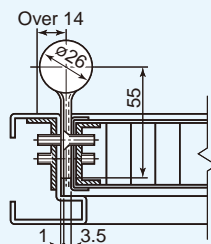

100series

Model 112

Model Number		Door Size Applicable(mm)			Door Weight (kg)	Closing Force (N-m)	Stop Mechanism	Location of Stop	Max. Opening Angle	Surface Color
Right hand door	Left hand door	W	H	D						
112R	112L	900(Max)	2100(Max)	30(Min)	40(Max)	10.0	—	85° & 150°	180° Left or Right One-side Opening	Silver & Bronze
112SR	112SL									
Empty Hinge	110R / 110L									



EXTERNAL DIMENSIONS

Left Hand Door

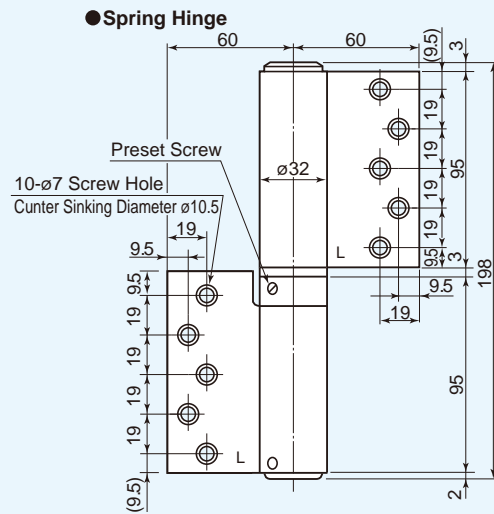

Right Hand Door

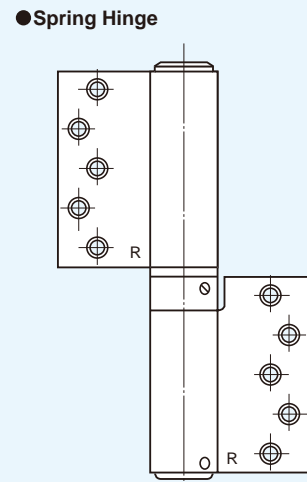

● Damper Hinge

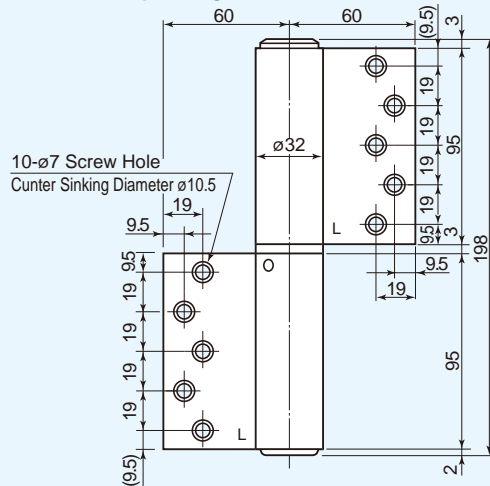

● Damper Hinge

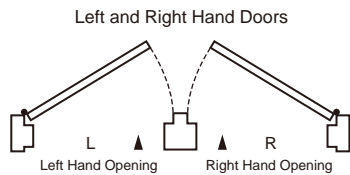
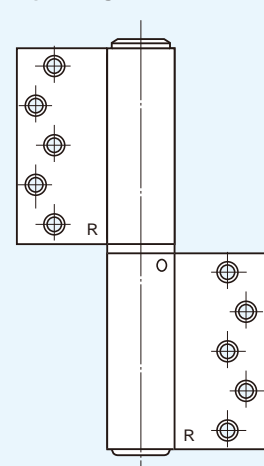

Remarks

1. The door and frame materials to which the hinge is to be fitted should be of hard wood such as lauan or harder.
2. Because the attached screws for fitting are 25mm long, the thickness of the frame should be over 25mm.
3. Allow at least 5mm of space between outer edge of door and frame.
4. The R type is also available for the corner of blade.
5. Surface treatment is by a baked coating of melamine resin.
6. Always allow for a door stopper to prevent the door from opening wider than 180°.

FITTING DIAGRAMS

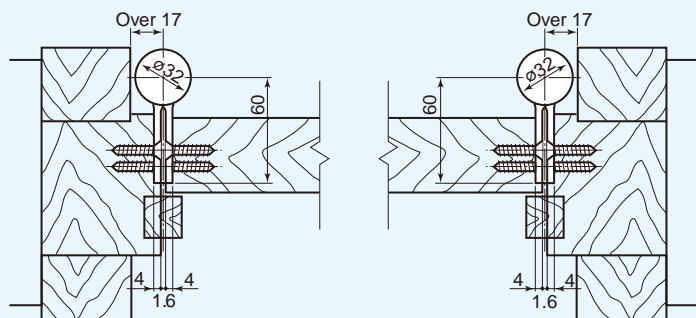

Model Number		Door Size Applicable(mm)			Door Weight (kg)	Closing Force (N-m)	Stop Mechanism	Location of Stop	Max. Opening Angle	Surface Color		
Right hand door	Left hand door	W	H	D								
122R-T	122L-T	900(Max)	2100(Max)	30(Min)	40(Max)	10.0	—	—	180° Left or Right One-side Opening	Silver		
122SR-T	122SL-T										○	85° & 150°
Empty Hinge	120R-T / 120L-T										—	—



EXTERNAL DIMENSIONS

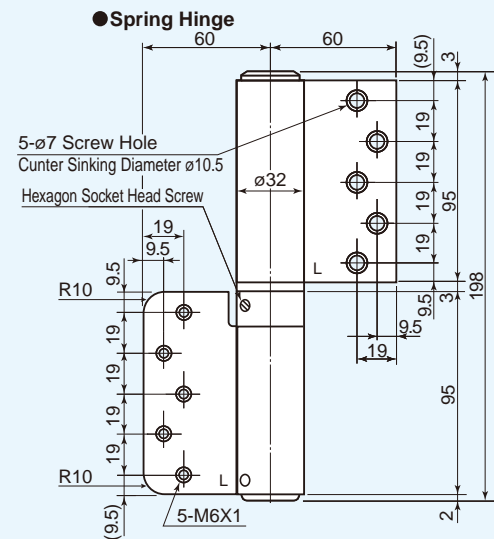

Right Hand Door

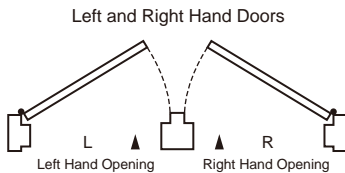
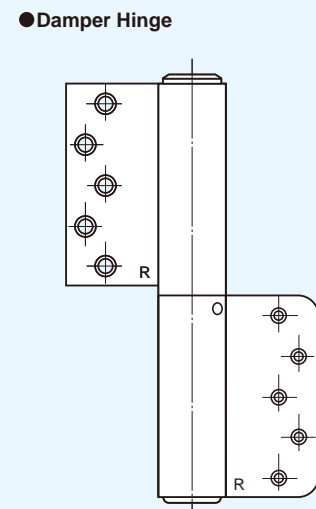
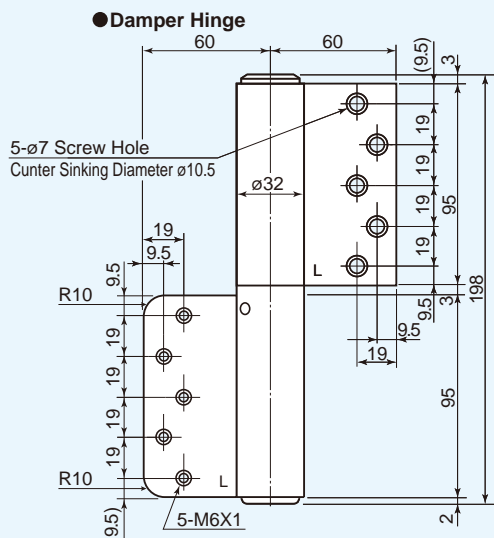
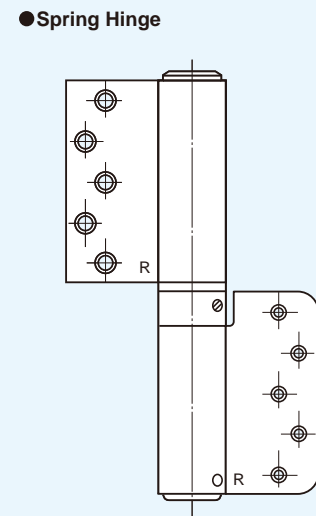

Remarks

1. For the blade fitting place on the frame, a steel plate of over 2.3mm thickness and 300mm length must be used as a reinforcing material.
2. For the blade fitting on the frame, use M6 flat screw. (Avoid installation by welding.)
3. For the blade fitting place on the door use a hard wood such as lauan or harder.
4. Allow at least 5mm of space between at outer edge of door and frame.
5. Surface treatment is by a baked coating of melamine resin.
6. Always allow for a door stopper to prevent the door from opening wider than 180°.

FITTING DIAGRAMS

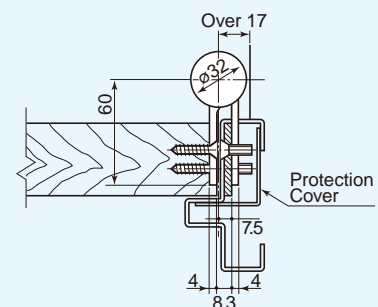
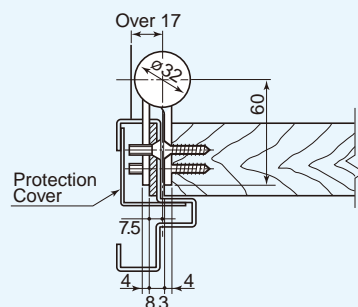

100 series

Model 113

Model Number			Door Size Applicable(mm)			Door Weight (kg)	Closing Force (N-m)	Stop Mechanism	Location of Stop	Max. Opening Angle	Surface Color
Right hand door	Left hand door		W	H	D						
113R	113L		900(Max)	2100(Max)	30(Min)	60(Max)	15.0	— ○	85° & 150°	180° Left or Right One-side Opening	Silver
113SR	113SL										
Empty Hinge	110R	110L									

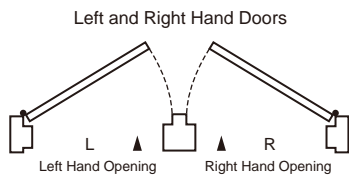

Remarks

1. The door and frame materials to which the hinge is to be fitted should be of hard wood such as lauan or harder.
2. Because the attached screws for fitting are 25mm long, the thickness of the frame should be over 25mm.
3. Allow at least 5mm of space between outer edge of door and frame.
4. The edge type is also available for the corner of leaves.
5. Surface treatment is by a baked coating of melamine resin.
6. Always allow for a door stopper to prevent the door from opening wider than 180°.

EXTERNAL DIMENSIONS

Left Hand Door

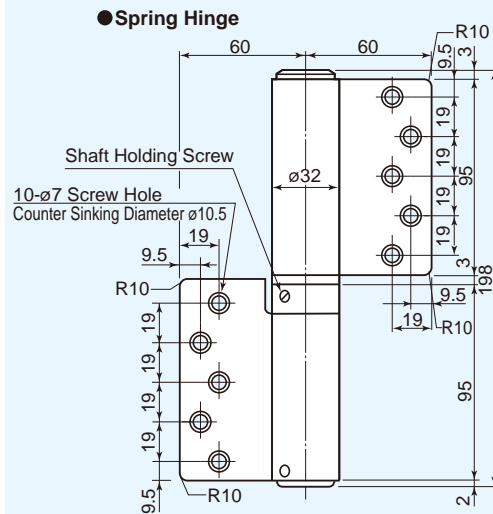

Right Hand Door

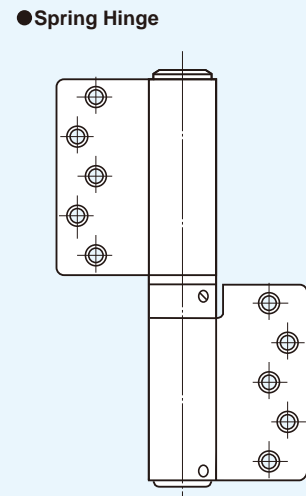

● Damper Hinge

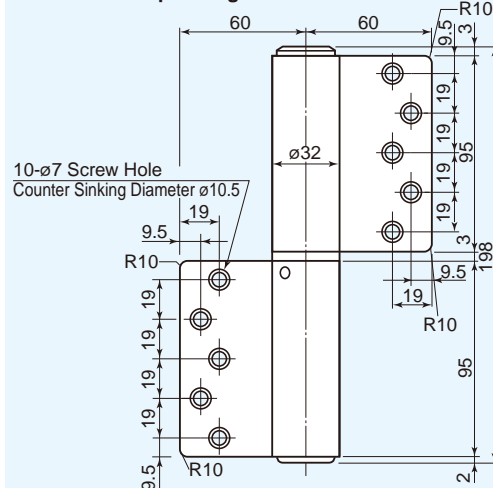

● Damper Hinge

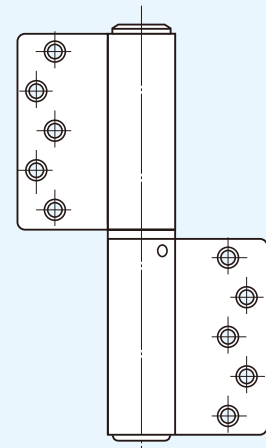

FITTING DIAGRAMS

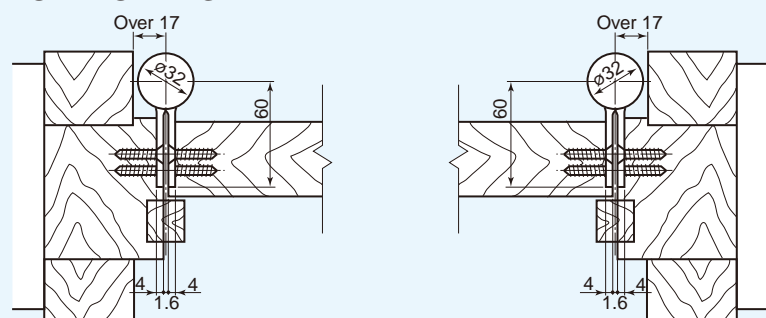

100series

Model 113 (TRI-SET)

Model Number		Door Size Applicable(mm)			Door Weight (kg)	Closing Force (N-m)	Stop Mechanism	Location of Stop	Max. Opening Angle	Surface Color
Right hand door	Left hand door	W	H	D						
113R (TRI-SET)	113L (TRI-SET)	1000(Max)	2200(Max)	30(Min)	80(Max)	20.0	—	—	180° Left or Right One-side Opening	Silver
113SR (TRI-SET)	113SL (TRI-SET)									
—		—			—		—		—	

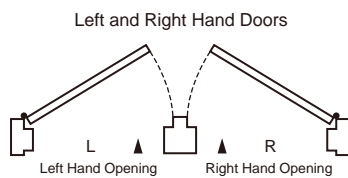

Remarks

1. The door and frame materials to which the hinge is to be fitted should be of hard wood such as lauan or harder.
2. Because the attached screws for fitting are 30mm long, the thickness of the frame should be over 30mm.
3. Allow at least 5mm of space between outer edge of door and frame.
4. The edge type is also available for the corner of leaves.
5. Surface treatment is by a baked coating of melamine resin.
6. Always allow for a door stopper to prevent the door from opening wider than 180°.

EXTERNAL DIMENSIONS

Left Hand Door

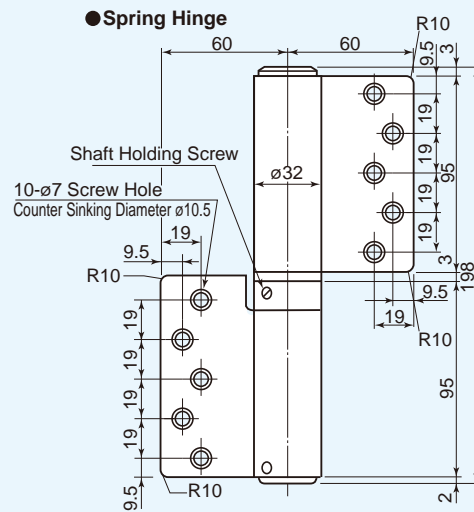

Right Hand Door

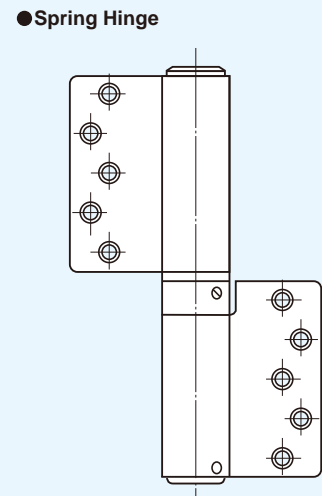

● Damper Hinge

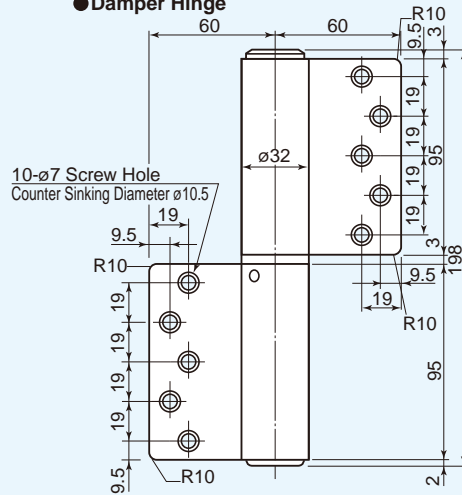

● Damper Hinge

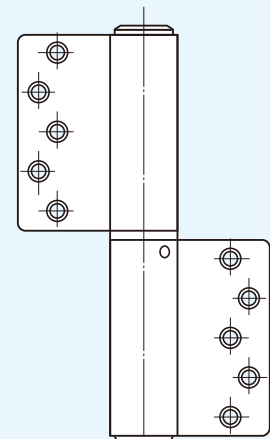

FITTING DIAGRAMS

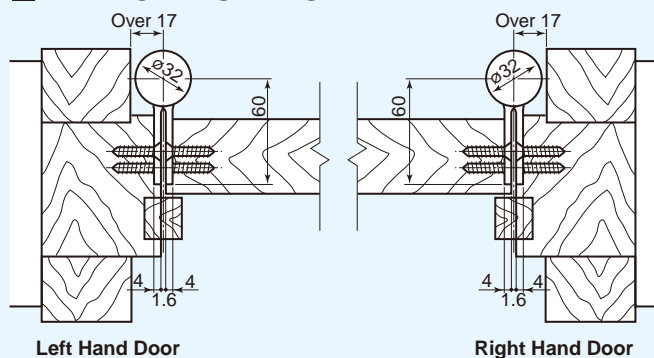

Installation

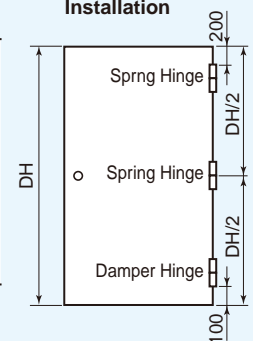

Model Number			Door Size Applicable(mm)			Door Weight (kg)	Closing Force (N·m)	Stop Mechanism	Location of Stop	Max. Opening Angle	Surface Color
Right hand door	Left hand door		W	H	D						
122R-AT	122L-AT		900(Max)	2100(Max)	30(Min)	40(Max)	10.0	—	—	180° Left or Right One-side Opening	Silver
122SR-AT	122SL-AT										
Empty Hinge	120R-AT	120L-AT									

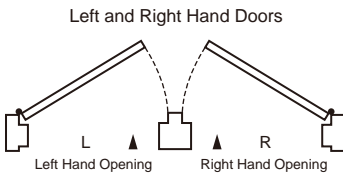

Remarks

- For the blade fitting place on the frame, a steel plate of over 2.3mm thickness and 300mm length must be used as a reinforcing material.
- For the blade fitting on the frame, use M6 flat screw. (NOT include)
□ dimension can be used. when cut the blade. (Avoid installation by welding.)
- For the blade fitting place on the door use a hard wood such as lauan or harder.
- Allow at least 5mm of space between at outer edge of door and frame.
- Surface treatment is by a baked coating of melamine resin.
- Always allow for a door stopper to prevent the door from opening wider than 180°.

EXTERNAL DIMENSIONS

Left Hand Door

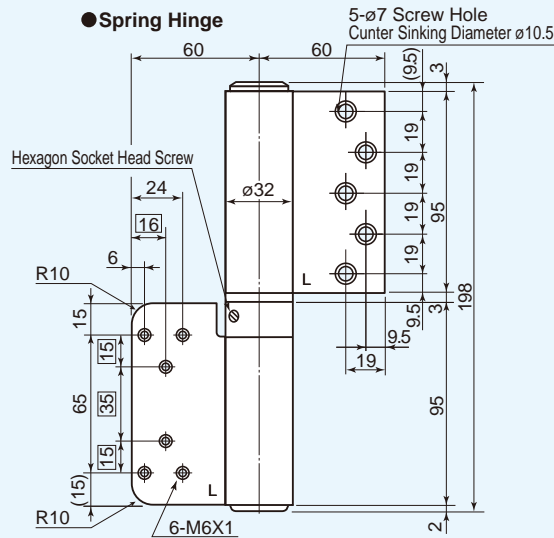

Right Hand Door

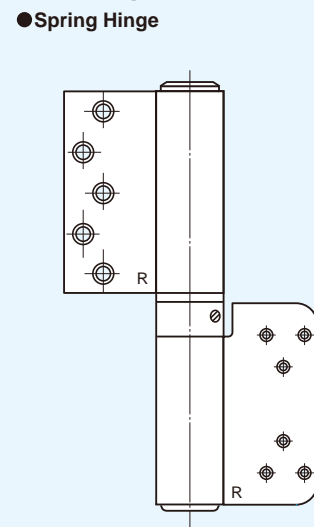

Damper Hinge

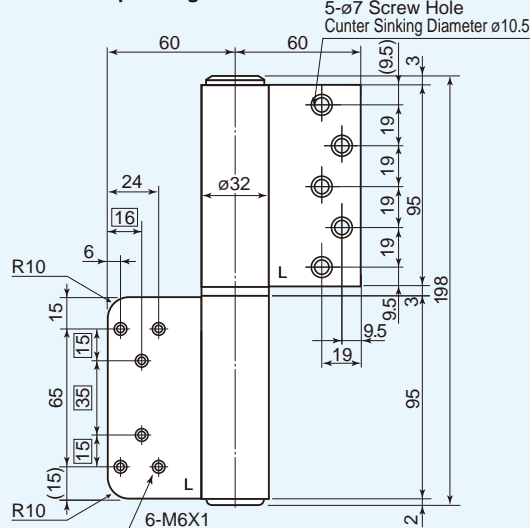

Damper Hinge

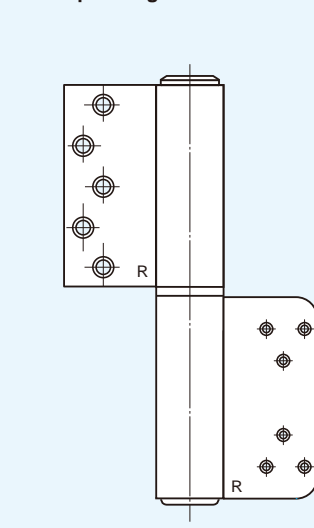

FITTING DIAGRAMS

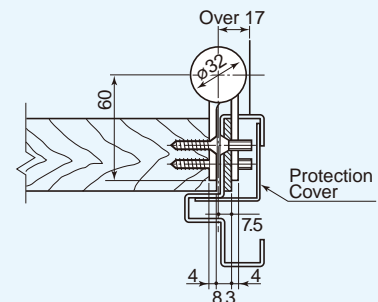
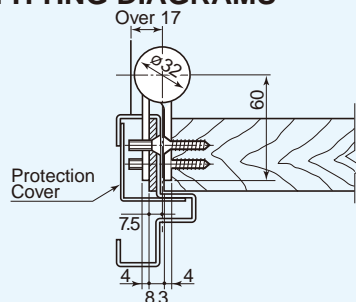

Model Number		Door Size Applicable(mm)			Door Weight (kg)	Closing Force (N-m)	Stop Mechanism	Location of Stop	Max. Opening Angle	Surface Color		
Right hand door	Left hand door	W	H	D								
132R	132L	900(Max)	2100(Max)	30(Min)	40(Max)	10.0	—	—	180° Left or Right One-side Opening	Silver		
132SR	132SL										○	85° & 150°
Empty Hinge	130R										130L	—



EXTERNAL DIMENSIONS

Left Hand Door

● Spring Hinge

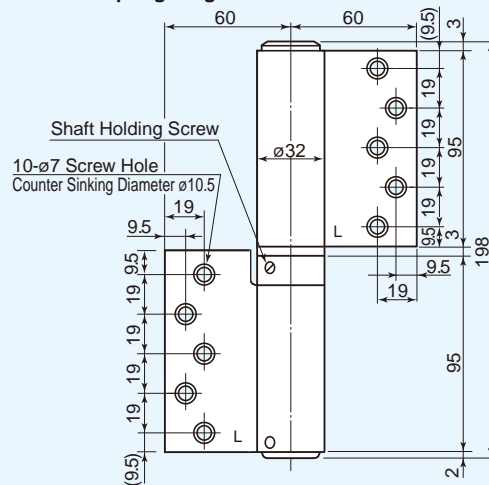

Right Hand Door

● Spring Hinge

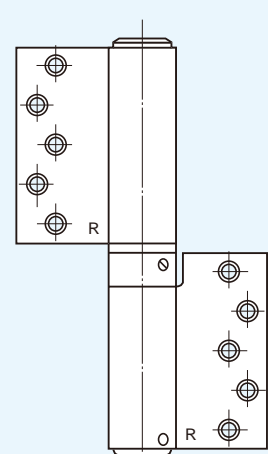

● Damper Hinge

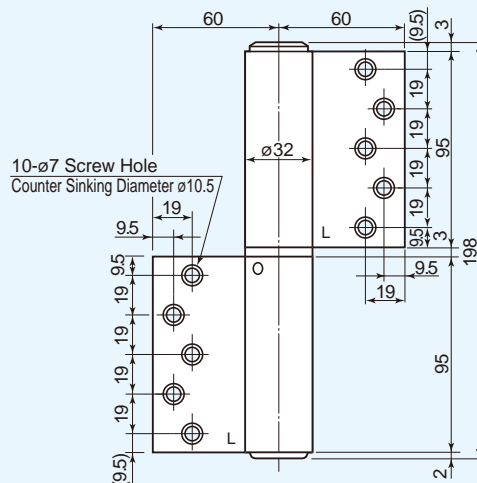

● Damper Hinge

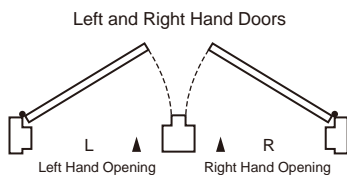
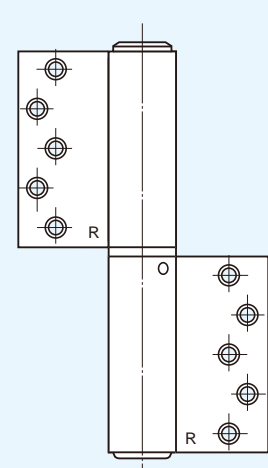

Remarks

1. For the wing fitting place on the door and frame, a steel plate of over 2.3mm thickness and 300mm length must be used as a reinforcing material.
2. Use the screws included in package for installation.
3. Allow at least 5mm of space between outer edge of door and frame.
4. Surface treatment is by a baked coating of melamine resin.
5. Always allow for a door stopper to prevent the door from opening wider than 180°.

FITTING DIAGRAMS

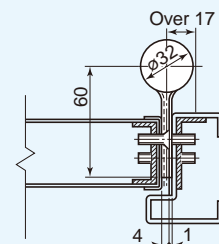
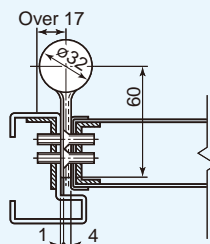

100series Model 143T

Model Number			Door Size Applicable(mm)			Door Weight (kg)	Closing Force (N-m)	Stop Mechanism	Location of Stop	Max. Opening Angle	Surface Color
Right hand door	Left hand door	W	H	D							
143R-T	143L-T	900(Max)	2100(Max)	30(Min)	60(Max)	15.0	—	—	180° Left or Right One-side Opening	Silver	
143SR-T	143SL-T										
Empty Hinge	140R-T / 140L-T										

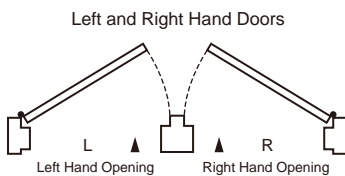

Remarks

1. For the blade fitting place on the door and frame, a steel plate of over 2.3mm thickness and 300mm length must be used as a reinforcing material.
2. For the blade fitting on the door and frame, use M6 flat screw X5 pcs. (Avoid installation by welding.)(not include)
3. In case of applying to a fire protection door, use the model (143R, 143L) without a stop.
4. Allow at least 5mm of space between at outer edge of door and frame.
5. Surface treatment is by a baked coating of melamine resin.
6. Always allow for a door stopper to prevent the door from opening wider than 180°.

EXTERNAL DIMENSIONS
Left Hand Door

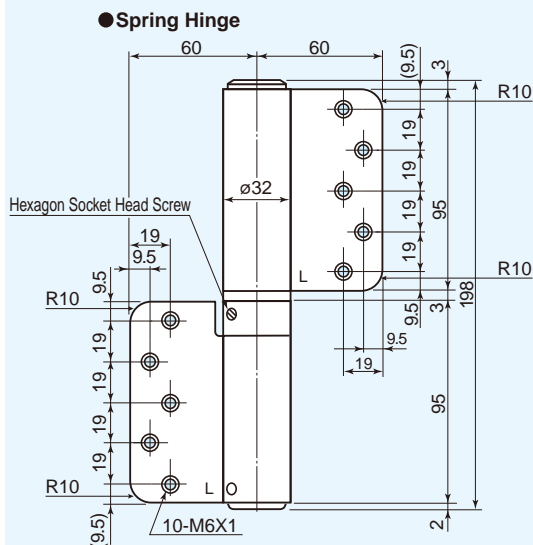

Right Hand Door
● Spring Hinge

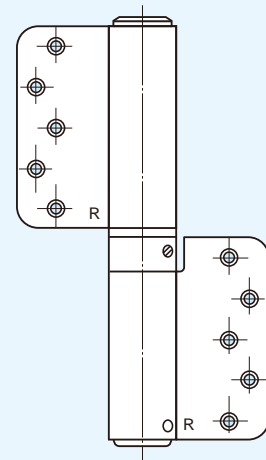

● Damper Hinge

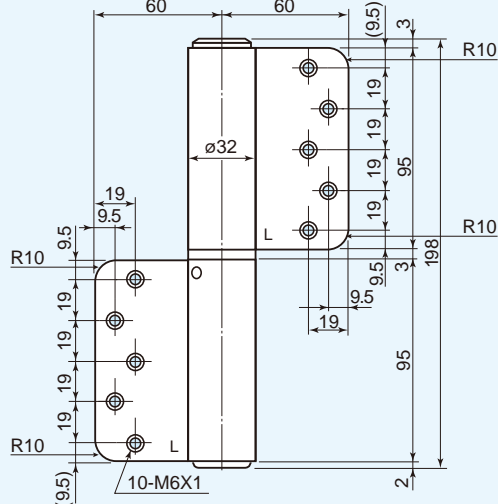

● Damper Hinge

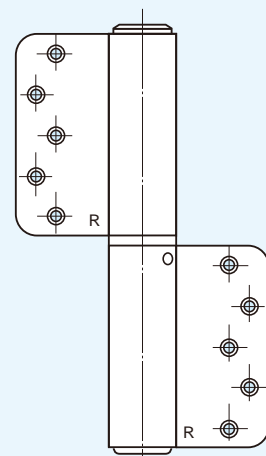

FITTING DIAGRAMS

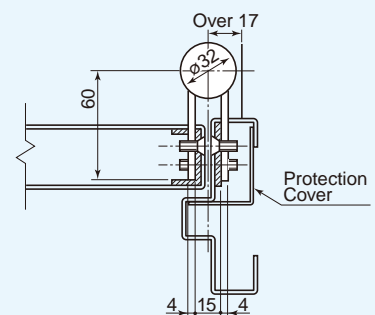
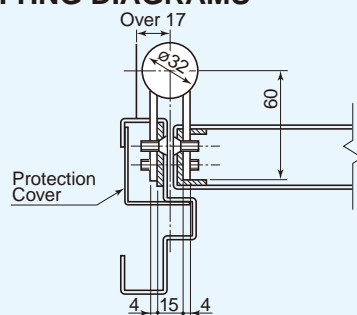

100series

Model 143AT

Model Number		Door Size Applicable(mm)			Door Weight (kg)	Closing Force (N-m)	Stop Mechanism	Location of Stop	Max. Opening Angle	Surface Color
Right hand door	Left hand door	W	H	D						
143R-AT	143L-AT	900(Max)	2100(Max)	30(Min)	60(Max)	15.0	—	—	180° Left or Right One-side Opening	Silver
143SR-AT	143SL-AT									
Empty Hinge	140R-AT / 140L-AT					—	—	—		

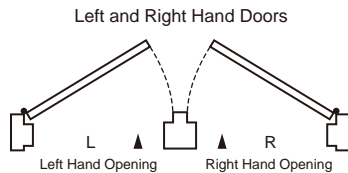

Remarks

- For the blade fitting place on the frame, a steel plate of over 2.3mm thickness and 300mm length must be used as a reinforcing material.
- For the blade fitting on the frame, use M6 flat screw X5 pcs. (NOT include)
 [] dimension can be used. when cut the blade. (Avoid installation by welding.)
- For the blade fitting place on the door use a hard wood such as lauan or harder.
- Allow at least 5mm of space between at outer edge of door and frame.
- Surface treatment is by a baked coating of melamine resin.
- Always allow for a door stopper to prevent the door from opening wider than 180°.

EXTERNAL DIMENSIONS

Left Hand Door

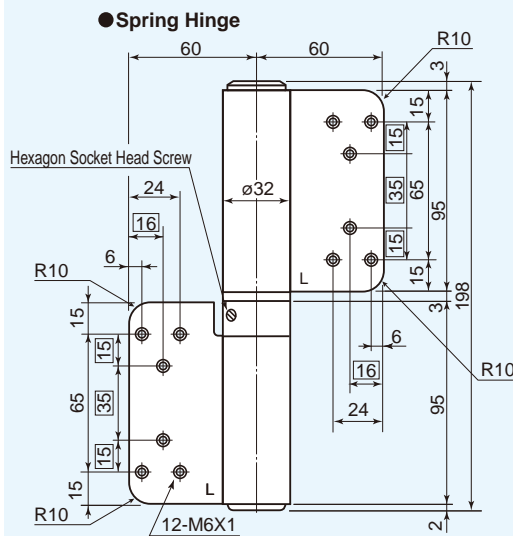

Right Hand Door

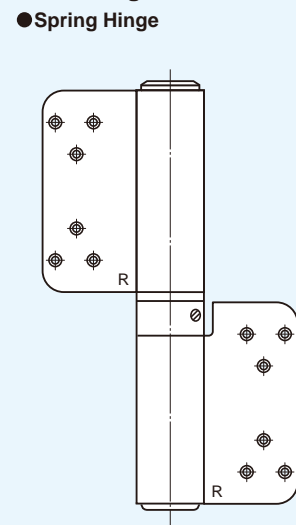

● Damper Hinge

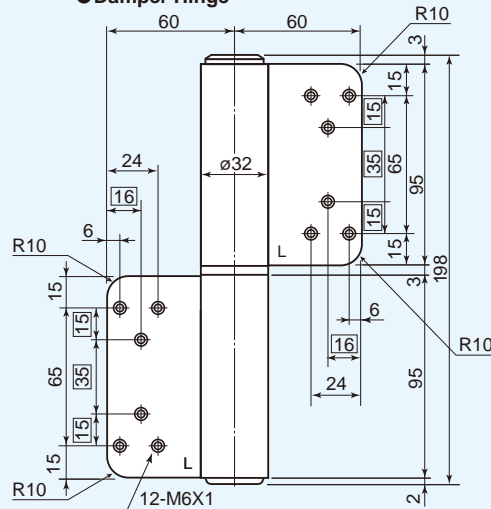

● Damper Hinge

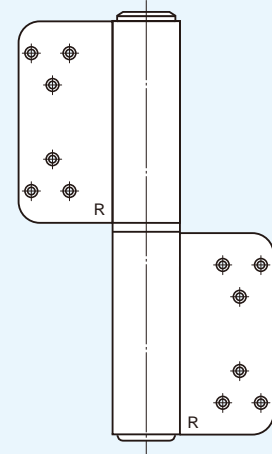

FITTING DIAGRAMS

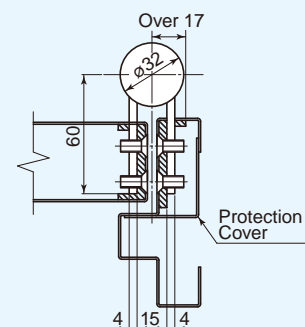
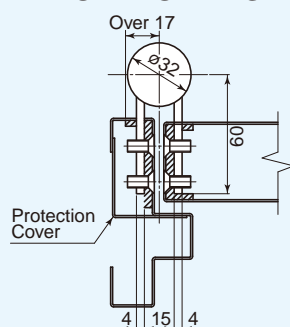

200series

Model 244T

Model Number			Door Size Applicable(mm)			Door Weight (kg)	Closing Force (N·m)	Stop Mechanism	Location of Stop	Max. Opening Angle	Surface Color
Right hand door	Left hand door	W	H	D							
244R-T	244L-T	1200(Max)	2100(Max)	40(Min)	120(Max)	22.6	—	—	180° Left or Right One-side Opening	Silver	
244SR-T	244SL-T										85° & 150°
Empty Hinge	240R-T / 240L-T					—	—	—	—	—	—

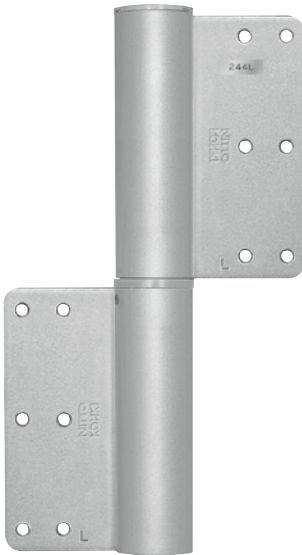

EXTERNAL DIMENSIONS

Left Hand Door

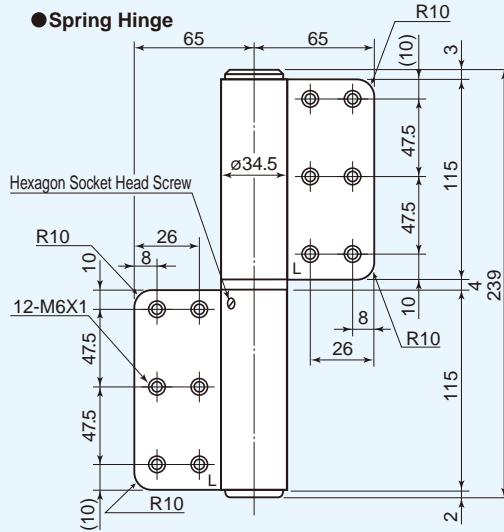

Right Hand Door

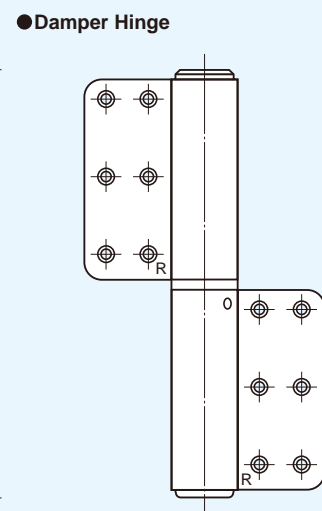
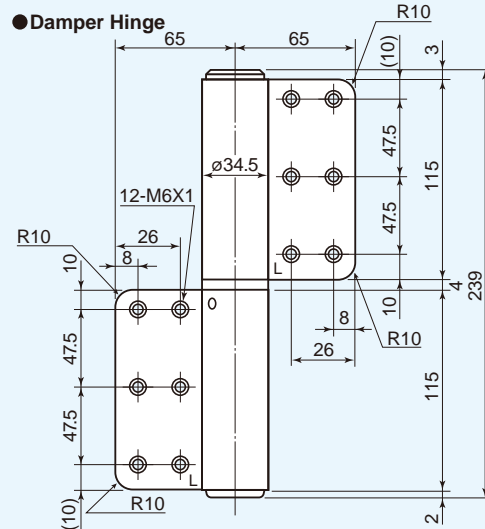
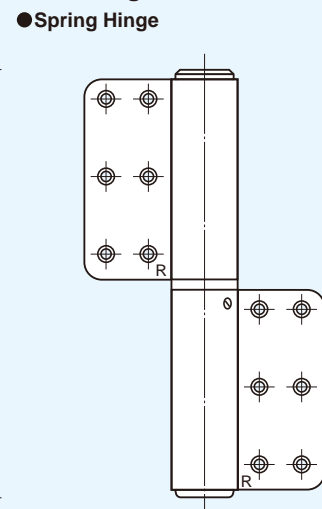

FITTING DIAGRAMS

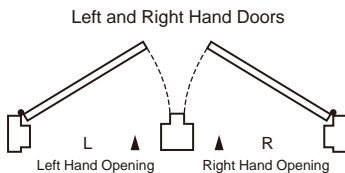
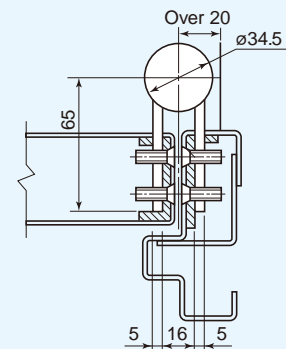
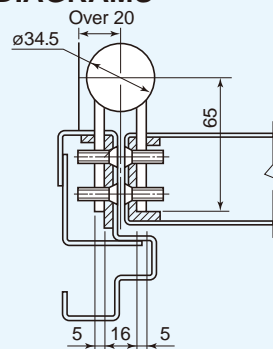

Remarks

1. For the blade fitting place on the door and frame, a steel plate of over 3.2mm thickness and 300mm length must be used as a reinforcing material.
2. For the blade fitting on the door and frame, use M6 flat screw X6 pcs. (Avoid installation by welding.)(Not include)
3. In case of applying to a fire protection door, use the model (244R-T, 244L-T) without a stop.
4. Allow at least 5mm of space between at outer edge of door and frame.
5. Surface treatment is by a baked coating of melamine resin.
6. Always allow for a door stopper to prevent the door from opening wider than 180°.

300 series

Installation procedure

- Suspend the door, then install the hinges.

Spring hinge

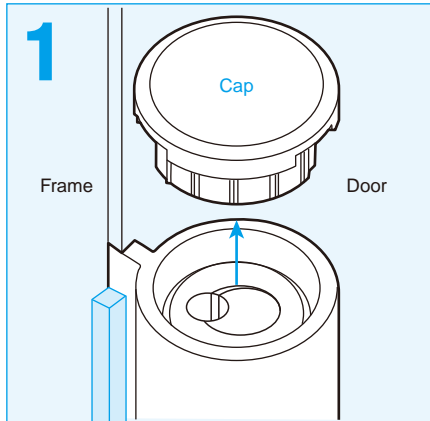

- Install the door, then remove the cap.

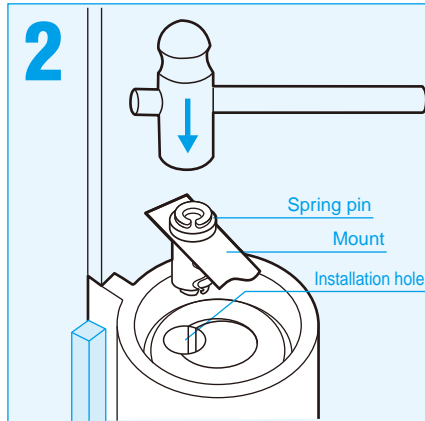

- Open the door 10° to 15° or so. Drive the furnished spring pin securely into the installation hole according to the explanations about the mount. Then install the cap.

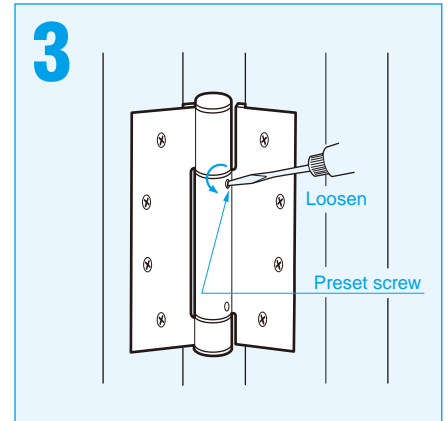

- Open the door about 90°. Turn the preset screw by 3 to 4 turns counterclockwise, then make it stick out from the hinge surface by about 1mm.

Damper hinge

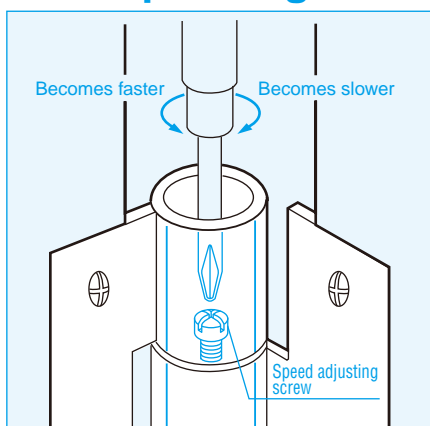

- Turn the speed adjusting screw according to the instructions given on the cap of the damper hinge, thus adjusting the door-closing speed. Then apply the cap.

Cautions on installation

- Center the spring hinge and damper hinge securely.

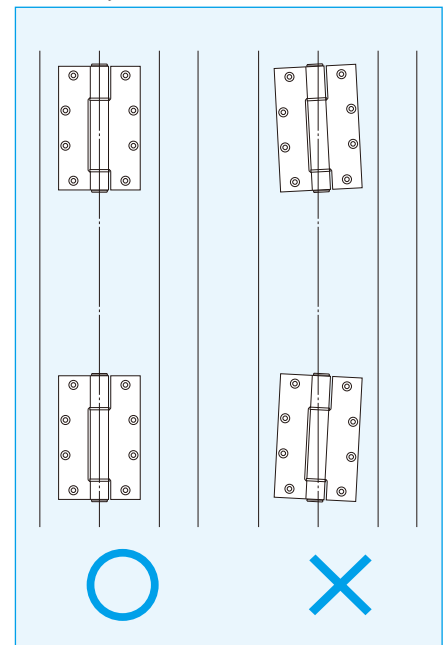

How to remove the door

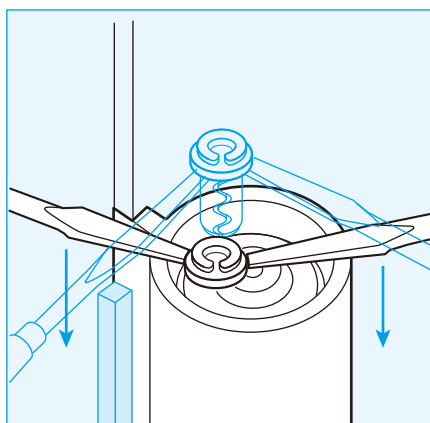

- ① Open the door about 90°, turn the preset screw clockwise by 3-4 turns, thus retightening it as before.
- ② Close the door, and the door will stop at about 5°. Detach the spring pin as shown in the left-hand figure. (Do not close the door by overstraining it before pulling out the spring pin.)
- ③ To make the spring work again, use a new spring pin.

1000 series

Installation procedure

- Suspend the door, then install the hinges.

*When suspending the door, align the notch in the shaft of the damper hinge with the hole in the door-side flap.

Spring hinge

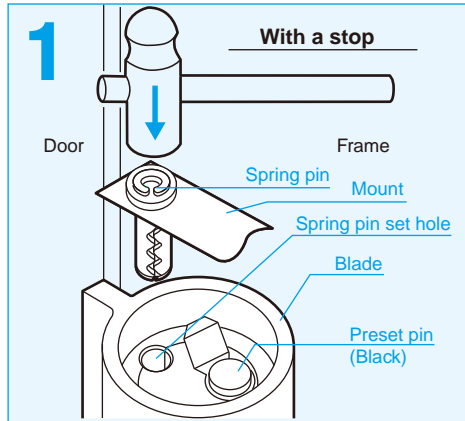

- With the door ajar about 5 to 15 degrees, hammer the silver colored spring pin into the spring set hole.

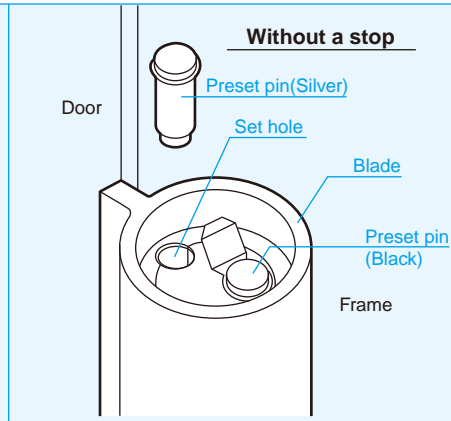

- With the door ajar about 5 to 15 degrees, insert the set pin firmly in to the spring set hole. The set pin (silver) is located inside the upper cap of the spring hinge.

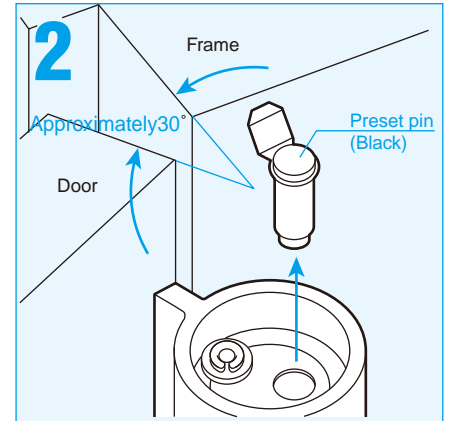

- Next open the door approximately 30° and make sure to pull out the black pre-set pin.

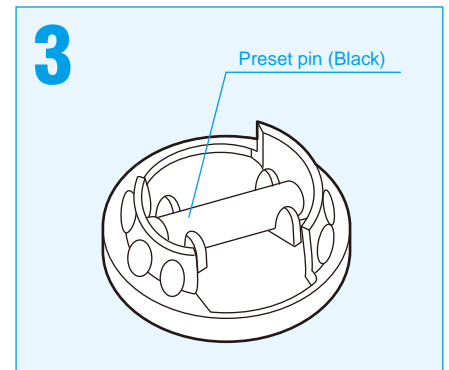

- Then place the pre-set pin you have just removed, in the cap and store it there.

Damper hinge

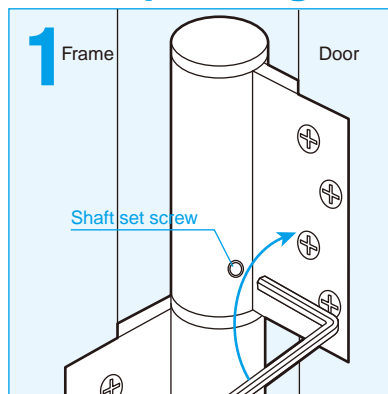

- Screw the damper hinge's hexagon socket head screw tightly with the hexagon wrench enclosed.

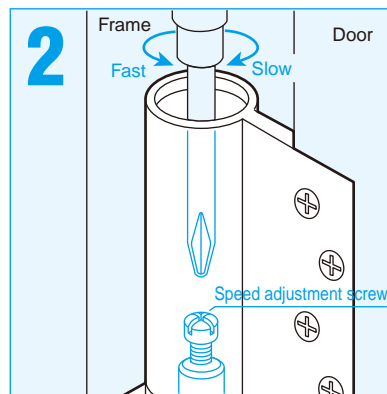

- Finally to set the door closing speed, turn the speed adjustment screw in the damper hinge to the desired speed.

Removal of the door

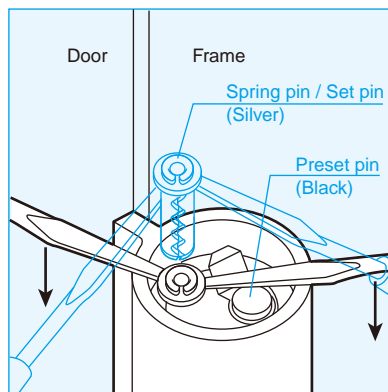

When taking off the Auto Hinge, do everything in exactly the opposite of when you fastened it to the door.

- ① When taking off the Auto Hinge, do everything in exactly the opposite of when you fastened it to the door.
- ② Loosen the damper hinge's hexagon socket screw. Next remove the spring hinge's upper cap. Open the door approximately 30° and take the stored preset pin from the cap. Then push it into the pre-set pin hole firmly. If you don't push it in firmly enough it may come out and the spring will become loose.
- ③ Close the door approximately 5° and take out the spring pin, as shown in the drawing on the left side. And you can take off the hinge.
- ④ It is dangerous to remove the fitting screws when the spring is still wound.

100/200/NK series

Installation procedure

- Suspend the door, then install the hinges.

*When suspending the door, align the notch in the shaft of the damper hinge with the hole in the door-side flap.

Spring hinge

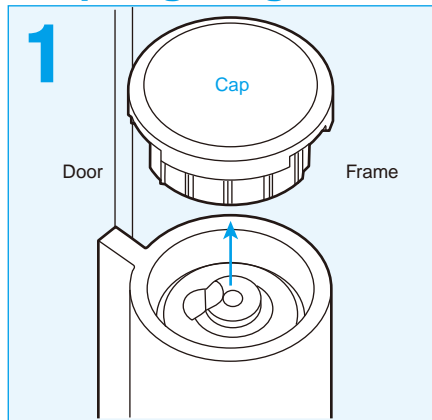

- Remove the cap.

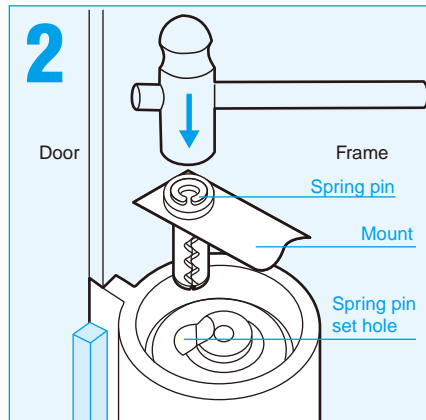

- Drive the spring pin.
- Open the door by about 0° to 10°, align the installation hole, and drive the spring pin securely according to the instructions given on the mount. Do not use a screw or anything similar as an alternative.

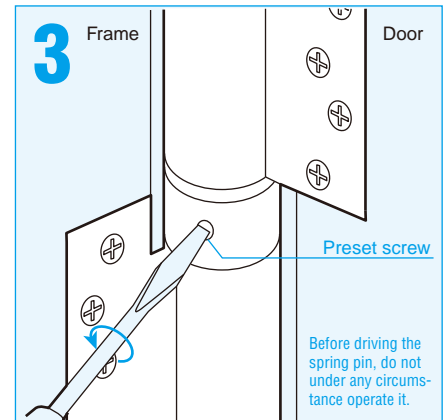

- Open the door by about 90°, turn the preset screw counterclockwise by 3-4 turns, and make it stick out by about 1mm from the hinge surface. Before driving the spring pin, do not under any circumstances operate it.

Damper hinge

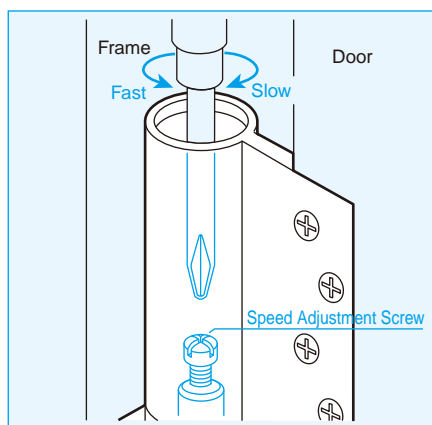

- Finally to set the door closing speed, remove the cap from damper hinge and turn the speed adjustment screw in the damper hinge to the desired.

Removal of the door

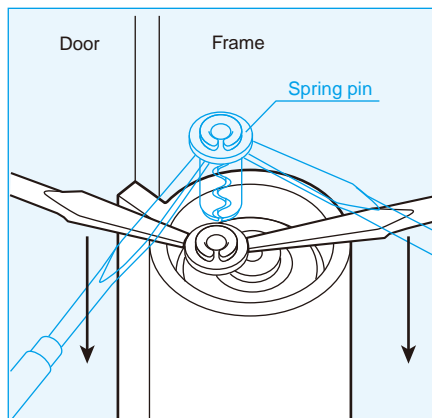

- ① Open the door by about 90°, turn the preset screw clockwise by 3-4 turns, and retighten it as before.
- ② Close the door, and it will stop at about 5°. Therefore pull out the spring pin as shown in the left-hand figure, then remove the door. (*Do not close the door by overstraining it before pulling out the spring pin.)
- ③ To suspend it again, do so at the angle at which the door was removed (the angle at which there is the shaft notch in the damper hinge).

700 series

Installation procedure

- Suspend the door, then install the hinges.

*When suspending the door, align the notch in the shaft of the damper hinge with the hole in the door-side flap.

● Spring hinge

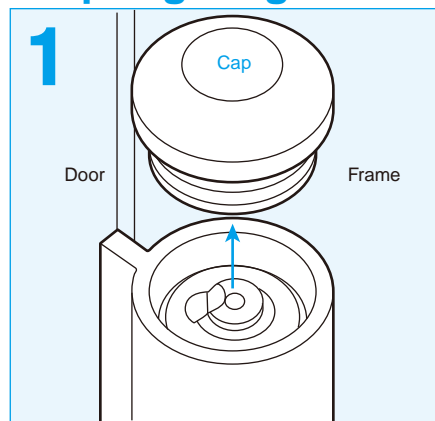

- Remove the cap.

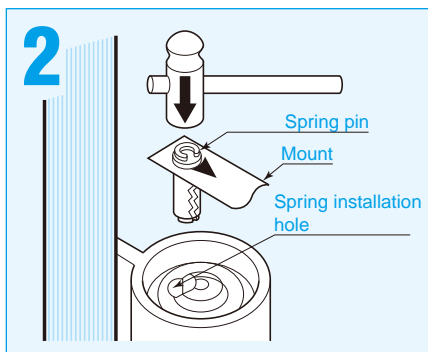

- Drive the spring pin.
- Open the door by about 0° to 10°, align the installation hole, and drive the spring pin securely according to the instructions given on the mount. Do not use a screw or anything similar as an alternative.

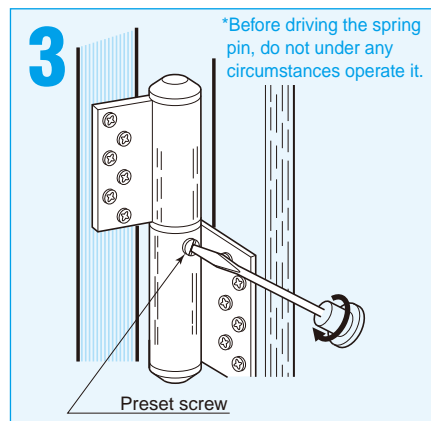

- Open the door by about 90°, turn the preset screw counterclockwise by 3-4 turns, and make it stick out by about 1mm from the hinge surface. Before driving the spring pin, do not under any circumstances operate it.

● Damper hinge

● How to suspend the door

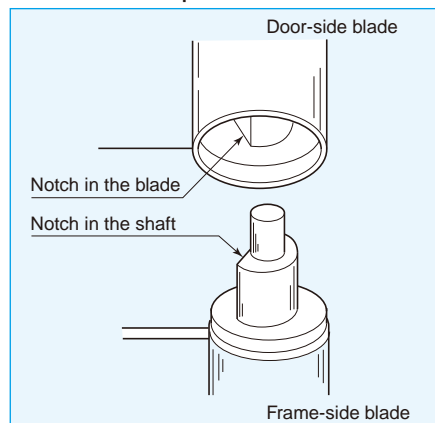

- Align the label on the cap with the notch in the shaft.
- The damper hinge, when handled singly, has a clearance between the top and the bottom blade. When it is installed and the door is suspended, the clearance will disappear, so that it will be installed to automatic speed adjustment. There is therefore no problem. After suspending the door, check that there is no clearance between the top and the bottom blade.

● How to set the door-closing speed

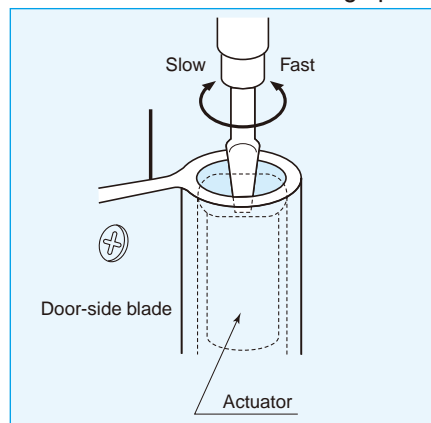

● How to remove the door

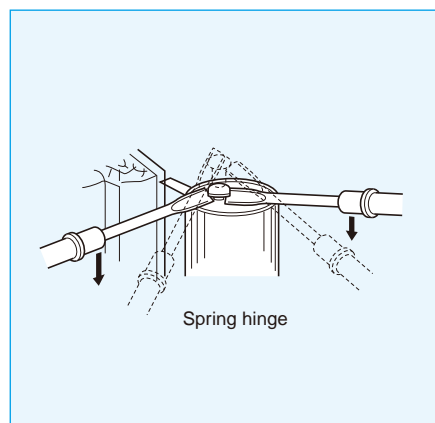

- ① Open the door by about 90°, turn the preset screw clockwise by 3-4 turns, and retighten it as before.
- ② Close the door, and it will stop at about 5°. Therefore pull out the spring pin as shown in the left-hand figure, then remove the door. (*Do not close the door by overstraining it before pulling out the spring pin.)
- ③ To suspend it again, do so at the angle at which the door was removed (the angle at which there is the shaft notch in the damper hinge).

*For any questions about the handling procedure, please consult the Hinge Sales Sect. or any office of Nitto Kohki.

*Should any hinge break down, pull out the spring pin (see "How to remove the door" in the figure above) and turn the speed adjusting screw to maximize the speed. You can then use it similarly to ordinary hinges.

AUTO HINGES

Mounting position Flag Type Auto Hinges

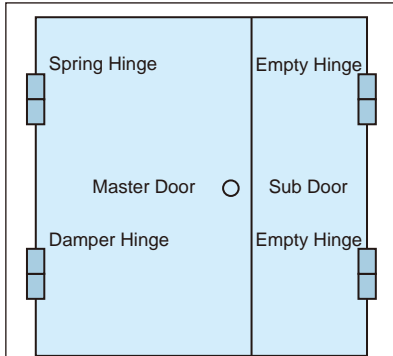

- In case the sub door doesn't require automatic closing mechanism, the empty hinges which is the same appearance as the Auto Hinge without interior mechanism can be applied.

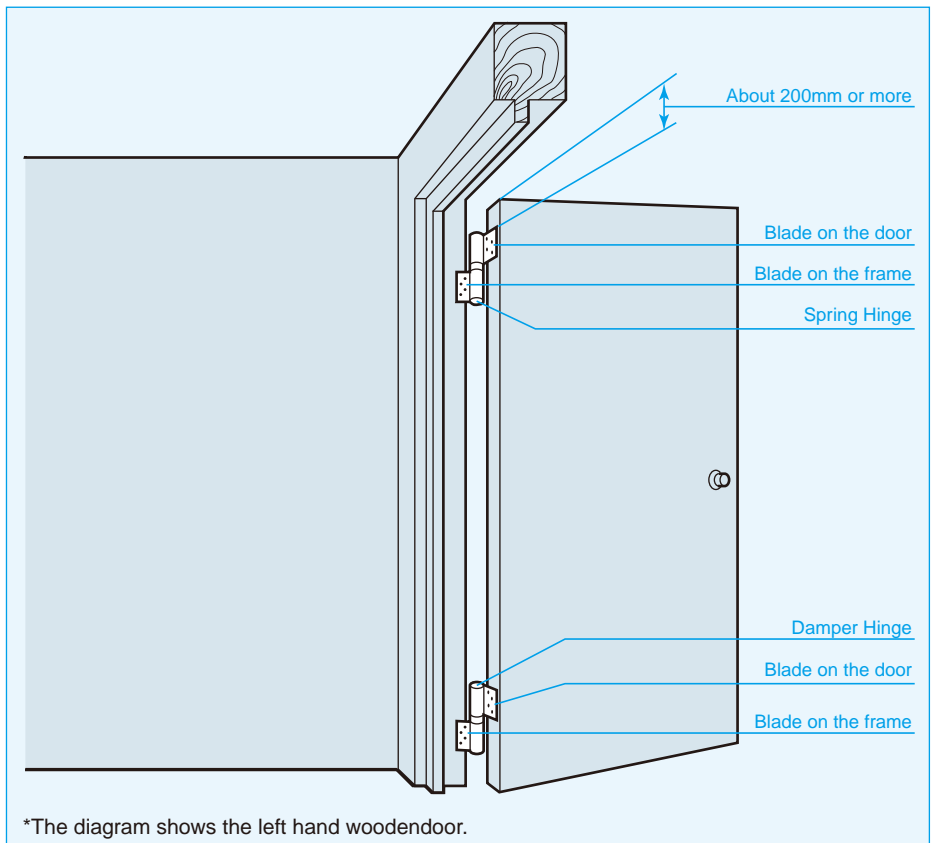

*The diagram shows the left hand wooddoor.

Handling precautions

- Attach the hinge blades in parallel with the door frame.

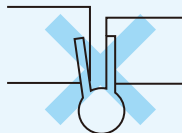

- Do not bend the blades.

- Do not hit the hinge with undue force.

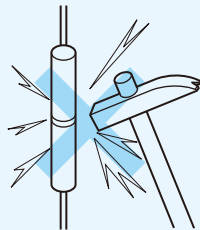

- Hold the door opening to 180 degrees or less.

Opening the door wider than 180 degrees would damage the clutch mechanism to prevent it from closing (that is, it remains locked). To avoid this, install a doorstop or similar obstacle.

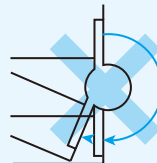

- Do not leave the Auto Hinge in places where it is exposed to direct moisture, or splash it with water. (Except pc and 700 series)

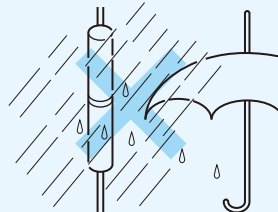

- Do not weld the blades.

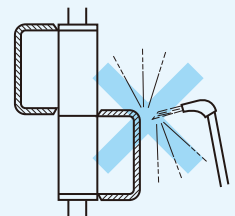

- Avoid bending the hinge blades, or using the hinge in places where it is exposed to strong winds.

OTHER RELATED PRODUCTS

Center Hang type



- Most suitable for fire protection, open smoke ventilation and normally-opened / closed doors and air supply doors.
- Concealed type (door built-in type.)

Concealed



- Can be selected stop or with out stop by select.
- 2 way closing speed.
- Door built-in type.

Create



- Projecting type door closer
- Automatically closes a door with quiet in combined use of a capsule with built-in spring and hydraulic device and a special pivot hinge.
- Simple design
- Provided with arm-free construction, presenting simple design and beauty fit for any door.

Sliding closer

- The endless, viscosity resistance system (patent pending) is employed to offer a compact, lightweight, long-life closer.
- The door closing speed can easily be adjusted for a desired level.
- The temperature compensation function (patent pending) is incorporated so that the closing speed remains virtually the same even when the ambient temperature changes.

Horizontal type

NSC Series

For Bath
NSC-CB Series

Inclined type

DSC Series



⚠ Safety precautions

- To avoid personal injury and other accidents, thoroughly read the precautions set forth in the "Instruction Manual" or "Catalog" and properly complete the installation and adjustment procedures before use.
- Ensure that the door closing speed is properly adjusted at all times. If it is too high, personal injury may result.

NITTO KOHKI CO.,LTD.

Head Office and Research Center
Nakaikigami 2-9-4, Ohta-ku, Tokyo 146-8555 Japan
Phone:03(3755)1111 Fax:03(3753)8791

Overseas Auto Hinge Sales Division
Yokoyama Bldg. 7F, Nishi-Nippori 2-40-3, Arakawa-ku,
Tokyo 116-0013 Japan
Phone:03(5850)5781 Fax:03(3801)6001

Product info http://www.nitto-kohki.co.jp/Seihin_Info/HINGE/

Contact us Kentokyo@nitto-kohki.co.jp

★ Specifications and designs are subject to change at any time without notice.



● This document was made with recycle paper, and printed using soy-based inks.