

# GS 700A

## SOFT-CLOSE HARDWARE FOR HANGING SLIDING DOOR

Optimal Door Specification:

Features:

1. Single slide with bi-directional soft closing.
2. Adjustable soft-closing travel according to the door weight.
3. Maximum soft closing travel: 115mm.

Weight Capacity: 100KG

Door Thickness: Min. 30mm.

Door width: Max. 1500mm, Min 530mm.

Door Height Adjustment:  $\pm 3$ mm with Quick Release Base

Including Screws: 6 pc's for Aluminum Track; 12 pc's for Quick Release Base

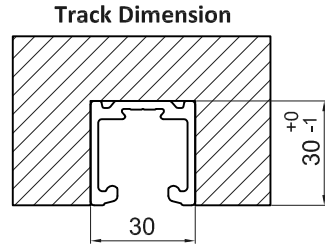

### GS 700A Components:

Contents	Bi-Directional Soft-Close Kits	Actuator	Allen Key	Repair Block	Adjustment Wrench	Quick Release Base	Hanger	Door Bottom Guide	Aluminum Track
Part									
Quantity	1	2	1	1	1	2	1	1	Not Included

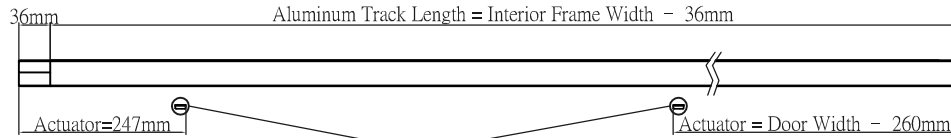

The weight of the door may influence the closing performance of the soft-close kits. Adjust the positions of the two actuators to attain the desired closing results.

Note: Make sure both sides are opened before installing.

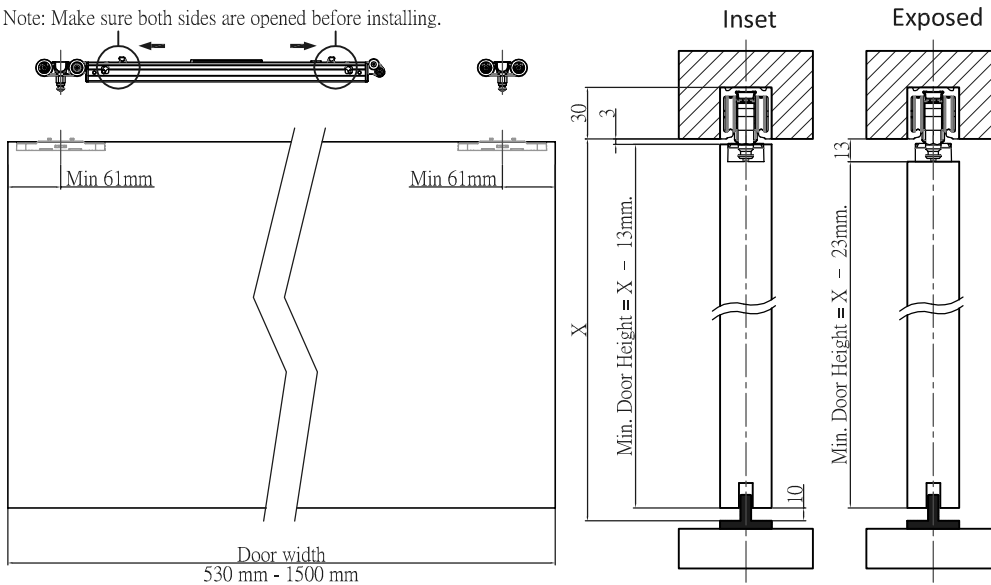

Size of the sink for assembling the quick release base on the door.

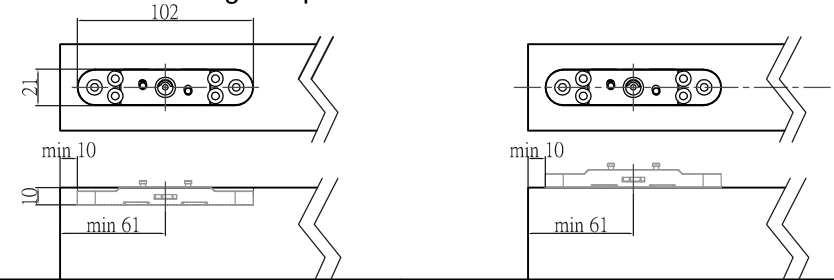

### Fixing the rail:

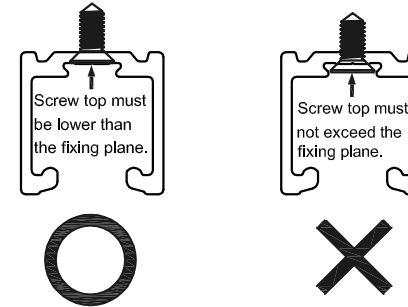

### Before disassembling the door:

1. Please place buffer under the gap of the door before disassembling, in order to prevent damage to the quick release base.

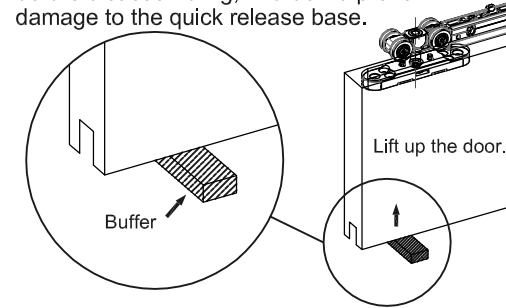

### Installation Procedures:

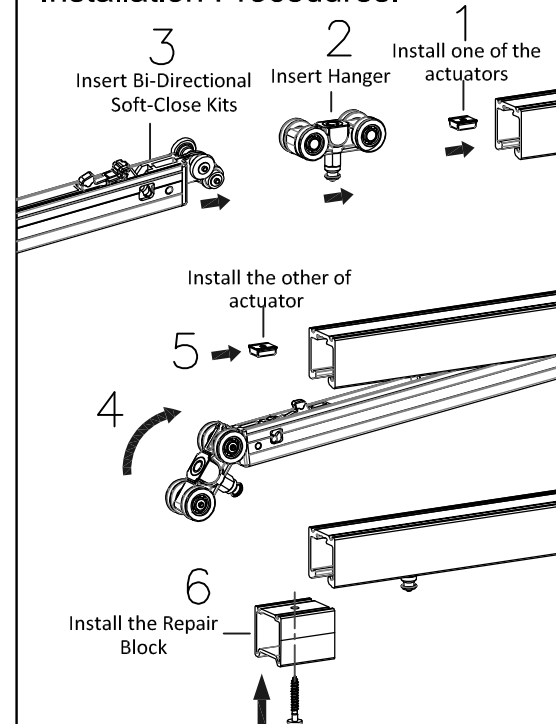

2. Please put the wrench between the hanger and the quick release base as the picture shows.

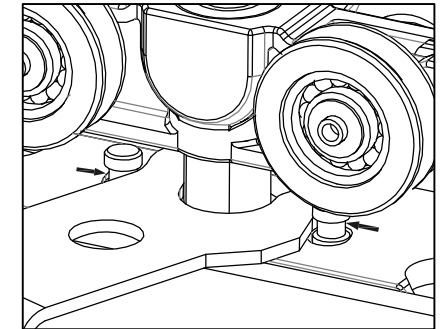

3. Please lift up the door before disassembling.

Turn the wrench clockwise about 8 degrees to disassemble the door.

