









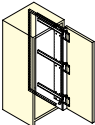

# WARDROBE & CABINET DOOR HARDWARE



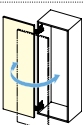

## POCKET DOOR SYSTEMS

| Picture   | Item Name              | Door Weight (kg) | Page      |
|---|------------------------|------------------|-----------|
|  | ALT-2V-220 (INSET)     | 5 - 10           | 602 - 607 |
|  | ALT-2V-5 (OVERLAY)     | 5 - 10           | 608 - 613 |
|  | ALT-F (INSET, FOLDING) | 10               | 614 - 615 |
|  | TSSL-2V (INSET)        | 20               | 616 - 617 |



## FLUSH / LATERAL OPENING DOOR SYSTEMS

| Picture   | Item Name                      | Door Weight (kg) | Page          |
|---|--------------------------------|------------------|---------------|
|   | FAD-5                          | 5                | 632           |
|  | LIN-X450, 600                  | 17, 24           | 624 - 628     |
|  | FAD-20                         | 20               | 633           |
|  | MFU-1000                       | 30               | 622 - 623     |
|  | FAD-44                         | 35               | 634 - 635     |
|  | FAD-54 (PARTITION)             | 35               | 636 - 637     |
|  | LIN-X800, LIN-X800H <b>NEW</b> | 40               | 601-1 - 601-2 |
|  | LIN-X1000                      | 90               | 629 - 631     |



## SLIDING DOOR SYSTEMS

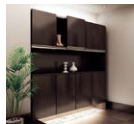





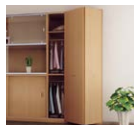











| Picture   | Item Name | Door Weight (kg)       | Page         |
|---|-----------|------------------------|--------------|
|  | ASDF-1    | 4                      | 643          |
|  | OX        | 5                      | 638 - 639    |
|  | XL-GC     | <b>FOR GLASS DOORS</b> | 12 640 - 642 |











## MULTIPLE MOTION DOOR SYSTEMS

| Picture   | Item Name | Door Weight (kg)                                     | Page                |
|---|-----------|--|---------------------|
|    | MFS-W     | 1.5 - 6.8  | 618 - 619           |
|   | MFS-G     | <b>FOR GLASS DOORS</b>                               | 1.5 - 6.7 620 - 621 |
|  | RB-600    | <b>STAINLESS 304 STEEL</b> Load Capacity (kgf): 75.5 | 650 - 651           |

## FOLDING DOOR SYSTEMS

| Picture   | Item Name | Door Weight (kg) | Page          |
|---|-----------|------------------|---------------|
|  | KF28      | 7                | 644 - 645     |
|  | FD30-F    | 15               | 646 - 649     |
|  | SFD       | 8                | 649-1 - 649-2 |

| HANGERS   |                        |   |      |
|---|------------------------|---|------|
| Picture   | Item Name              | Load Capacity (kgf)   | Page |
|    | TAW                    | 7 - 8   | 653  |
|    | TAS                    | 4 - 5   | 653  |
|    | TAT                    | 4 - 5   | 654  |
|    | UH                     |  3     | 657  |
|    | AS                     |  5     | 656  |
|   | WH                     | 4 - 6   | 656  |
|  | TE700, 800             | 20  | 657  |
|  | SH740                  | 41  | 658  |
|  | CK                     |  1.5 | 658  |
|  | HM-250V                |  3   | 659  |
|  | HM-250Y                |  3   | 659  |
|  | HM-330                 |  3   | 659  |
|  | PS-37<br>(PIPE HOLDER) | 20/2 pcs  | 659  |

| TIE RACKS   |           |   |
|---|-----------|---|
| Picture   | Item Name | Page  |
|    | TIEM      | 660   |
|    | TIE-33    | 660   |
|    | MST-20    | 661   |
|    | TR        | 661   |
|    | S-350     |  662   |
|  | STR       |  662  |
|  | DTR       |  662 |

## MONOFLAT LIN-X HINGE

Under Development



L=R

INSTRUCTION

LIN-X800

# MonoFlat LIN-X hinge

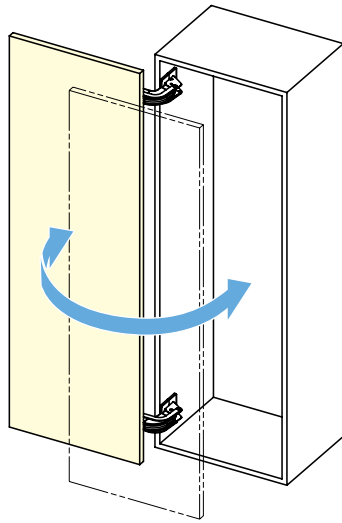

|                | LIN-X800             | LIN-X800H    |
|----------------|----------------------|--------------|
| Door Width     | 750 - 850 mm         |              |
| Door Height    | Max. 2400 mm         | Max. 2980 mm |
| Door Thickness | 24 - 40 mm           |              |
| Door Weight    | Max. 40 kg per door  |              |
| Usage          | 1 per door (Overlay) |              |

## Features

- Innovative movement keeps doors discretely out of the way.**  
 Door closes flush with surrounding walls for a sleek and clean design.  
 No need to do special processing on any wall for grooves or rails.  
 Can be used on aluminium frames (if the frame has a thickness over 120 mm).
- Whether open or closed, door stays out of the way**  
 Compared to regular swing doors, has a small radius allowing the space in front of the door to be used effectively.
- Opens fully for access to entire cabinet.**  
 Whether installing cabinets or just getting access, the entire cabinet interior is easily accessible.
- Built-in soft close mechanism**  
 When the door closes, the internal damper will cause the door to close softly, preventing slamming.
- 4 Way adjustment post installation**  
 Can be adjusted vertically, horizontally, depth or parallel.
- Wide amount of applicable cabinets**  
 Can be used on dual opening, single opening cabinets. Can also be used on L shaped corner spaces.

## Parts Included

- OTruss head tapping screw 6\*25
- Truss head screw M5 x 10
- M5 Square Nut
- One end mouth wrench

## Colour Variation



Black

White

WARDROBE &amp; CABINET DOOR HARDWARE

MONOFLAT LIN-X HINGE

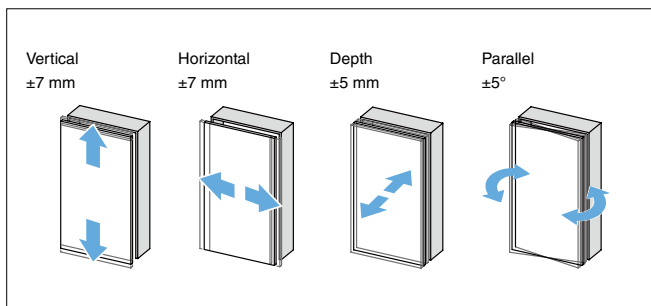

\*Vertical, Horizontal, Depth and Parallel adjustment possible post-installation.

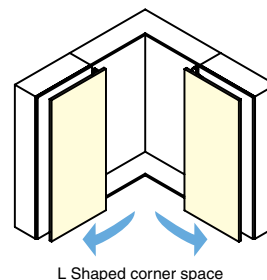
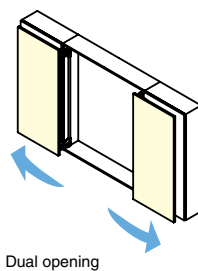
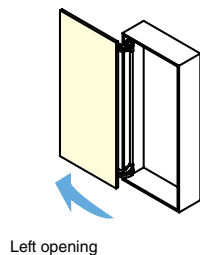
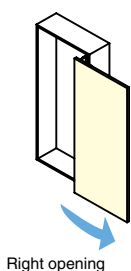

**MONO FLAT LIN-X HINGE**  
If ordering LIN-X800

• Be sure to order..... **Part Set (per door)**

**Part Set (per door)**

**This set must be ordered.** Select a suitable set according to the door height.

| CAD  | Item Code   | Item Name      | Door Height | Colour | Set Content (for LIN-X800)               |             |                  |                  |
|------|-------------|----------------|-------------|--------|--|-------------|------------------|------------------|
|      |             |                |             |        | 1 Hinge + 2 3 Washer Cover + 4 Rod Cover |             | 5 Connecting Rod |                  |
|      |             |                |             |        | Item Code                                | Item Name   | Item Code        | Item Name        |
| 2030 | 250-043-897 | LIN-X800-BL-S  | 2400 mm     | Black  | 250-043-834                              | LIN-X800-BL | 250-043-842      | LIN-X80-L2100-BL |
| 2030 | 250-043-898 | LIN-X800-WT-S  | or Less     | White  | 250-043-835                              | LIN-X800-WT | 250-043-843      | LIN-X80-L2100-SL |
| 2030 | 250-043-899 | LIN-X800H-BL-S | 2980 mm     | Black  | 250-043-834                              | LIN-X800-BL | 250-043-844      | LIN-X80-L2500-BL |
| 2030 | 250-043-900 | LIN-X800H-WT-S | or Less     | White  | 250-043-835                              | LIN-X800-WT | 250-043-845      | LIN-X80-L2500-SL |

Part Set Contents

| No. Quantity       | Parts in Set                | Dimensions | Specifications   |
|--------------------|-----------------------------|------------|--|
| 1<br>A - B<br>each | Hinge A                     |            | <ul style="list-style-type: none"> <li>Material: Steel (SPCC)/ Polyacetal (POM)</li> <li>Finish: Nickel Plating Baked enamel finish</li> </ul> |
|                    | Hinge B                     |            |  |
| 2                  | Washer cover (hanging side) |            | Material: ABS resin  |
| 3                  | Washer cover (leading edge) |            | Material: ABS resin  |
| 4                  | Rod cover                   |            | Material: Polyacetal (POM)   |

| No. Quantity     | Parts in Set   | Dimensions | Specifications  |
|------------------|----------------|------------|---|
| 5<br>Either part | Connecting rod |            | <ul style="list-style-type: none"> <li>Material: Aluminium alloy</li> <li>Finish: Anodised: Black/silver</li> </ul> |
|                  |                |            | <ul style="list-style-type: none"> <li>Material: Aluminium alloy</li> <li>Finish: Anodised: Black/silver</li> </ul> |

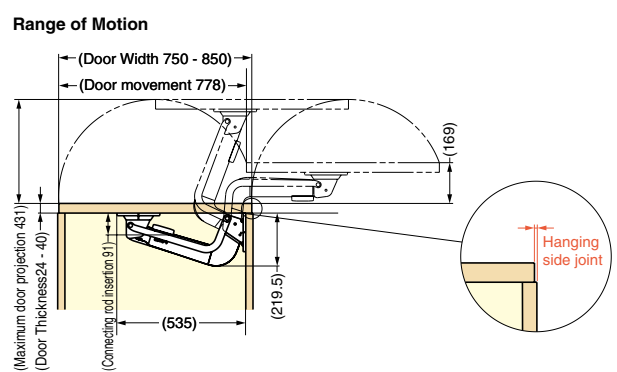
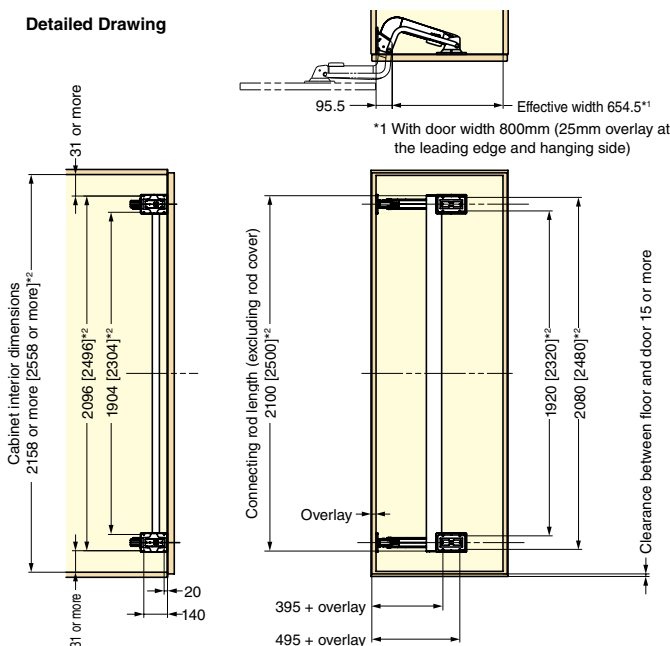

\*2 The dimensions in [ ] indicate LIN-X800H specifications.  
\*2 For cabinet interior dimensions smaller than the minimum value, reduce the other dimensions marked with \*2 by an equivalent amount. The connecting rod must be cut by the customer.

# POCKET DOOR SYSTEM (INSET)



## ALT-2V-220



WARDROBE & CABINET DOOR HARDWARE

| Item Name      | ALT-2V-220S-16 - 28<br>S Type<br>(2 Rails) | ALT-2V-220M-16 - 28<br>M Type<br>(3 Rails) | ALT-2V-220L-16 - 28<br>L Type<br>(3 Rails) | ALT-2V-220LL-16 - 28<br>LL Type<br>(4 Rails) |
|----------------|--|--|--|--|
| Door Width     | Max. 560 mm                                | Max. 560 mm                                | Max. 560 mm                                | Max. 600 mm                                  |
| Door Height    | 820 - 1060 mm                              | 1240 - 1500 mm                             | 1640 - 1840 mm                             | 1980 - 2300 mm                               |
| Door Thickness | 18 - 30 mm                                 |  |  |  |
| Door Weight    | Max. 5 kg                                  | Max. 6 kg                                  | Max. 8 kg                                  | Max. 10 kg                                   |

### Features

- Works on cabinet doors up to 2300mm in height and 600mm wide.
- Works on many sizes of horizontal opening cabinet doors. Designed for inset pocket doors.
- When open, doors can retract inside the cabinet, allowing full access (besides pocket) to inside of cabinet.
- Movement is extremely smooth due to slide rails.

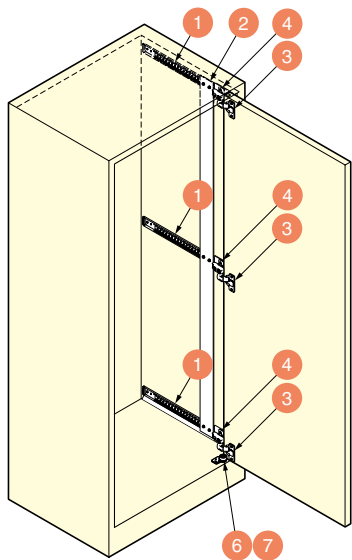
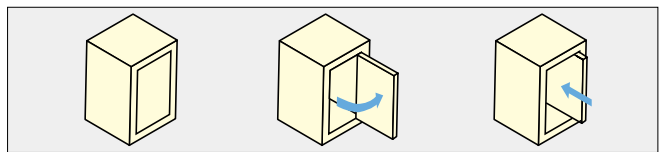

### Door Cut Out Dimensions

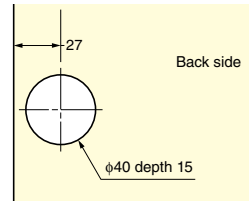

### Installation

#### Door storing

- 16 inch - 269 + Door thickness (270 + Door thickness)
- 19 inch - 345 + Door thickness (346 + Door thickness)
- 22 inch - 421 + Door thickness (422 + Door thickness)
- 24 inch - 472 + Door thickness (473 + Door thickness)
- 28 inch - 574 + Door thickness (575 + Door thickness)

### Rail Installation & Clearance Dimensions

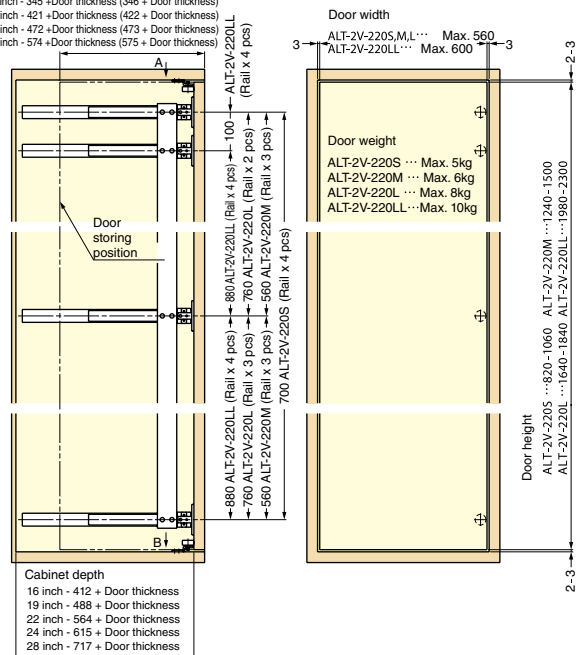
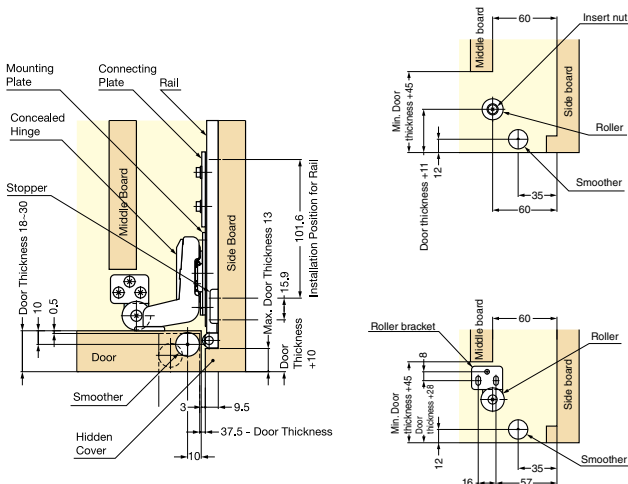

| Parts Set (Per Door) |             |                 | Necessary Parts |       |                    |      |                          |       |                  |       |           |       |                  |       |
|----------------------|-------------|-----------------|-----------------|-------|--------------------|------|--------------------------|-------|------------------|-------|-----------|-------|------------------|-------|
| Type                 | Item Code   | Item Name       | Part Name       |       |                    |      |                          |       |                  |       |           |       |                  |       |
|                      |             |                 | 1 Rail          |       | 2 Connecting Plate |      | 3 Concealed Hinge (Body) |       | 4 Mounting Plate |       | 5 Catch   |       | 6 - 10 Parts Set |       |
|                      |             |                 | Item Name       | Qty   | Item Name          | Qty  | Item Name                | Qty   | Item Name        | Qty   | Item Name | Qty   | Item Name        | Qty   |
| S                    | 180-120-930 | ALT-2V-220S-16  | AL127C-16       | 2 pcs | ALT55-S            | 1 pc | H230-C26/OT              | 2 pcs | ALT-MP           | 2 pcs | AL127-CH  | 1 pc  | ALT-2V-220SP     | 1 set |
|                      | 180-120-931 | ALT-2V-220S-19  | AL127C-19       | 2 pcs | ALT55-S            | 1 pc | H230-C26/OT              | 2 pcs | ALT-MP           | 2 pcs | AL127-CH  | 1 pc  | ALT-2V-220SP     | 1 set |
|                      | 180-120-932 | ALT-2V-220S-22  | AL127C-22       | 2 pcs | ALT55-S            | 1 pc | H230-C26/OT              | 2 pcs | ALT-MP           | 2 pcs | AL127-CH  | 1 pc  | ALT-2V-220SP     | 1 set |
|                      | 180-120-933 | ALT-2V-220S-24  | AL127C-24       | 2 pcs | ALT55-S            | 1 pc | H230-C26/OT              | 2 pcs | ALT-MP           | 2 pcs | AL127-CH  | 1 pc  | ALT-2V-220SP     | 1 set |
|                      | 180-120-934 | ALT-2V-220S-28  | AL127C-28       | 2 pcs | ALT55-S            | 1 pc | H230-C26/OT              | 2 pcs | ALT-MP           | 2 pcs | AL127-CH  | 1 pc  | ALT-2V-220SP     | 1 set |
| M                    | 180-120-935 | ALT-2V-220M-16  | AL127C-16       | 3 pcs | ALT55-M            | 1 pc | H230-C26/OT              | 3 pcs | ALT-MP           | 3 pcs | AL127-CH  | 2 pcs | ALT-2V-220LP     | 1 set |
|                      | 180-120-936 | ALT-2V-220M-19  | AL127C-19       | 3 pcs | ALT55-M            | 1 pc | H230-C26/OT              | 3 pcs | ALT-MP           | 3 pcs | AL127-CH  | 2 pcs | ALT-2V-220LP     | 1 set |
|                      | 180-120-937 | ALT-2V-220M-22  | AL127C-22       | 3 pcs | ALT55-M            | 1 pc | H230-C26/OT              | 3 pcs | ALT-MP           | 3 pcs | AL127-CH  | 2 pcs | ALT-2V-220LP     | 1 set |
|                      | 180-120-938 | ALT-2V-220M-24  | AL127C-24       | 3 pcs | ALT55-M            | 1 pc | H230-C26/OT              | 3 pcs | ALT-MP           | 3 pcs | AL127-CH  | 2 pcs | ALT-2V-220LP     | 1 set |
|                      | 180-120-939 | ALT-2V-220M-28  | AL127C-28       | 3 pcs | ALT55-M            | 1 pc | H230-C26/OT              | 3 pcs | ALT-MP           | 3 pcs | AL127-CH  | 2 pcs | ALT-2V-220LP     | 1 set |
| L                    | 180-120-940 | ALT-2V-220L-16  | AL127C-16       | 3 pcs | ALT55-L            | 1 pc | H230-C26/OT              | 3 pcs | ALT-MP           | 3 pcs | AL127-CH  | 2 pcs | ALT-2V-220LP     | 1 set |
|                      | 180-120-941 | ALT-2V-220L-19  | AL127C-19       | 3 pcs | ALT55-L            | 1 pc | H230-C26/OT              | 3 pcs | ALT-MP           | 3 pcs | AL127-CH  | 2 pcs | ALT-2V-220LP     | 1 set |
|                      | 180-120-942 | ALT-2V-220L-22  | AL127C-22       | 3 pcs | ALT55-L            | 1 pc | H230-C26/OT              | 3 pcs | ALT-MP           | 3 pcs | AL127-CH  | 2 pcs | ALT-2V-220LP     | 1 set |
|                      | 180-120-943 | ALT-2V-220L-24  | AL127C-24       | 3 pcs | ALT55-L            | 1 pc | H230-C26/OT              | 3 pcs | ALT-MP           | 3 pcs | AL127-CH  | 2 pcs | ALT-2V-220LP     | 1 set |
|                      | 180-120-944 | ALT-2V-220L-28  | AL127C-28       | 3 pcs | ALT55-L            | 1 pc | H230-C26/OT              | 3 pcs | ALT-MP           | 3 pcs | AL127-CH  | 2 pcs | ALT-2V-220LP     | 1 set |
| LL                   | 180-120-945 | ALT-2V-220LL-16 | AL127C-16       | 4 pcs | ALT55-LL           | 1 pc | H230-C26/OT              | 4 pcs | ALT-MP           | 4 pcs | AL127-CH  | 2 pcs | ALT-2V-220LLP    | 1 set |
|                      | 180-120-946 | ALT-2V-220LL-19 | AL127C-19       | 4 pcs | ALT55-LL           | 1 pc | H230-C26/OT              | 4 pcs | ALT-MP           | 4 pcs | AL127-CH  | 2 pcs | ALT-2V-220LLP    | 1 set |
|                      | 180-120-947 | ALT-2V-220LL-22 | AL127C-22       | 4 pcs | ALT55-LL           | 1 pc | H230-C26/OT              | 4 pcs | ALT-MP           | 4 pcs | AL127-CH  | 2 pcs | ALT-2V-220LLP    | 1 set |
|                      | 180-120-948 | ALT-2V-220LL-24 | AL127C-24       | 4 pcs | ALT55-LL           | 1 pc | H230-C26/OT              | 4 pcs | ALT-MP           | 4 pcs | AL127-CH  | 2 pcs | ALT-2V-220LLP    | 1 set |
|                      | 180-120-949 | ALT-2V-220LL-28 | AL127C-28       | 4 pcs | ALT55-LL           | 1 pc | H230-C26/OT              | 4 pcs | ALT-MP           | 4 pcs | AL127-CH  | 2 pcs | ALT-2V-220LLP    | 1 set |

WARDROBE & CABINET DOOR HARDWARE







POCKET DOOR SYSTEM (INSET)

| Optional Parts |      |             |                    |            |  |
|----------------|------|-------------|--------------------|------------|--|
| No.            | Qty  | Item Code   | Part Name          | Dimensions | Description  |
| 11             | 1 pc | 180-120-340 | Side Mount Bracket |            | <ul style="list-style-type: none"> <li>Material: Steel</li> <li>Finish: Yellow Zinc Chromate</li> </ul> See P.606 for Details. |

# ALT-2V-220 PARTS SET DETAILS

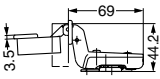
WARDROBE & CABINET DOOR HARDWARE

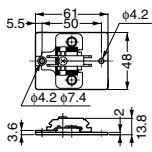
POCKET DOOR SYSTEM (INSET)

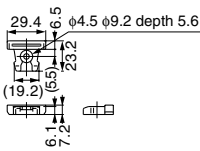
| No. | Qty   |       |       |       | Part Name  | Dimensions  | Description  |
|-----|-------|-------|-------|-------|--|---|--|
|     | S     | M     | L     | LL    |  |   |  |
| 1   | 2 pcs | 3 pcs | 3 pcs | 4 pcs | <b>Rail</b><br>                     | As below.   | Item Code : 190-113-867<br>Item Name : AL127C-16<br><br>Item Code : 190-113-868<br>Item Name : AL127C-19<br><br>Item Code : 190-113-869<br>Item Name : AL127C-22<br><br>Item Code : 190-113-870<br>Item Name : AL127C-24<br><br>Item Code : 190-113-871<br>Item Name : AL127C-28<br><br>• Material<br>Steel<br>• Finish<br>Clear Zinc Chromate |
| 2   | 1 pc  | 1 pc  | 1 pc  | 1 pc  | <b>Connecting Plate</b><br>         | As below.   | Item Code : 180-120-526<br>Item Name : ALT55-S<br><br>Item Code : 180-120-525<br>Item Name : ALT55-M<br><br>Item Code : 180-120-524<br>Item Name : ALT55-L<br><br>Item Code : 180-120-523<br>Item Name : ALT55-LL<br><br>• Material<br>Aluminium Alloy<br>• Finish<br>Anodized Silver  |
| 3   | 2 pcs | 3 pcs | 3 pcs | 4 pcs | <b>Concealed Hinge (Body)</b><br> |  | Item Code : 160-079-412<br>Item Name : H230-C26/0T<br><br>• Material<br>Steel<br>• Finish<br>Nickel<br><br>w/ Catch  |
| 4   | 2 pcs | 3 pcs | 3 pcs | 4 pcs | <b>Mounting Plate</b><br>         |  | Item Code : 160-120-535<br>Item Name : ALT-MP<br><br>• Material<br>Steel<br>• Finish<br>Nickel   |
| 5   | 1 pc  | 2 pcs | 2 pcs | 2 pcs | <b>Catch</b><br>                  |  | Item Code : 180-120-522<br>Item Name : AL127-CH<br><br>• Material<br>PUR<br>• Finish<br>Black  |

• Rail Dimensions

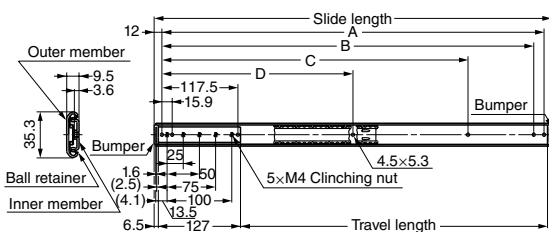

| Item Name | Slide Length | Travel Length | Door Storage | A     | B     | C     | D     |
|-----------|--------------|---------------|--------------|-------|-------|-------|-------|
| AL127C-16 | 411.4        | 269.4         | 268          | 387.4 | 371.5 | 269.9 | -     |
| AL127C-19 | 487.6        | 345.6         | 344          | 463.6 | 447.7 | 346.1 | 231.8 |
| AL127C-22 | 563.8        | 421.8         | 420          | 539.8 | 523.9 | 422.3 | 269.9 |
| AL127C-24 | 614.6        | 472.6         | 471          | 590.6 | 574.7 | 473.1 | 295.3 |
| AL127C-28 | 716.2        | 574.2         | 573          | 692.2 | 676.3 | 574.7 | 346.1 |



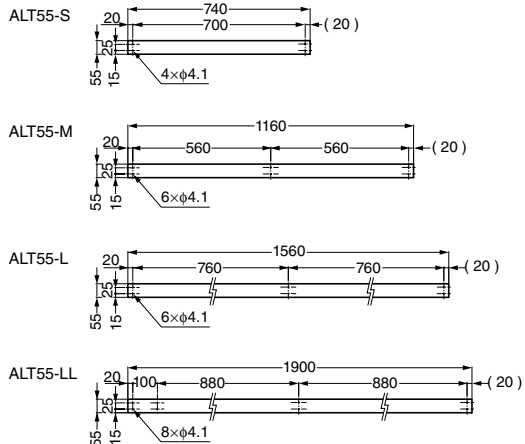





• Connecting Plate Dimensions

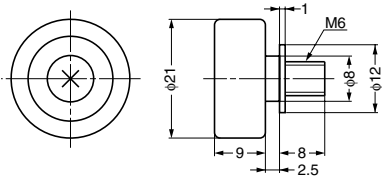

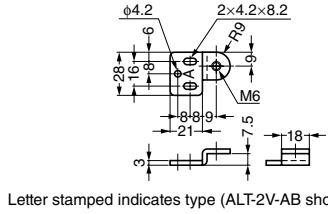

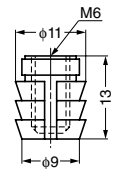
Parts Set Details

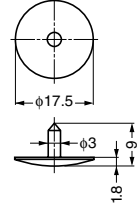
- a Item Code: 180-110-588 Item Name: ALT-2V-220SP
- b Item Code: 180-032-767 Item Name: ALT-2V-220LP
- c Item Code: 180-110-590 Item Name: ALT-2V-220LLP

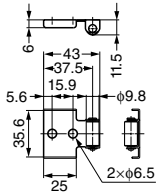
| No. | Qty                        |                            |                            | Part Name   | Dimensions   | Description   |
|-----|----------------------------|----------------------------|----------------------------|---|--|---|
|     | a                          | b                          | c                          |   |  |   |
| 6   | 2 pcs                      | 2 pcs                      | 2 pcs                      | Roller<br>         |    | Item Code : 180-940-144<br>Item Name : DU19-B4SBR<br>• Material<br>EPDM / Steel<br>• Finish<br>Clear Zinc Chromate / White  |
| 7   | 1 pair<br>(Left and Right) | 1 pair<br>(Left and Right) | 1 pair<br>(Left and Right) | Roller Bracket<br> |  <p>Letter stamped indicates type (ALT-2V-AB shown).</p> | Item Code : 180-930-145<br>Item Name : ALT-2V-AB<br><br>Item Code : 180-930-146<br>Item Name : ALT-2V-BB<br>• Material<br>Steel<br>• Finish<br>Yellow Zinc Chromate |
| 8   | 2 pcs                      | 2 pcs                      | 2 pcs                      | Insert<br>         |    | Item Code : 120-041-310<br>Item Name : SC-107-13<br>• Material<br>PA<br>• Finish<br>White   |
| 9   | 2 pcs                      | 2 pcs                      | 2 pcs                      | Slider<br>       |    | Item Code : 210-030-123<br>Item Name : G-175<br>• Material<br>PE<br>• Finish<br>Natural   |
| 10  | 2 pcs                      | 3 pcs                      | 4 pcs                      | Door Stopper<br> |    | Item Code : 180-930-416<br>Item Name : ALT-AD<br>• Material<br>UR / Steel<br>• Finish<br>Clear Zinc Chromate / White  |

Parts Included

Hex key, Pan head screw M4x6, Binding head tapping screw, Countersunk head tapping screw, Hexagon top bolt M4x6

WARDROBE & CABINET DOOR HARDWARE

POCKET DOOR SYSTEM (INSET)

**Temporary Installation of Rail 1**

- Fix 1 onto 10.
- Mount 1 inside the cabinet (temporary).
- Fix 4 onto Inner member of 1.
- Attach 5 to 1 as per the drawing on the right.

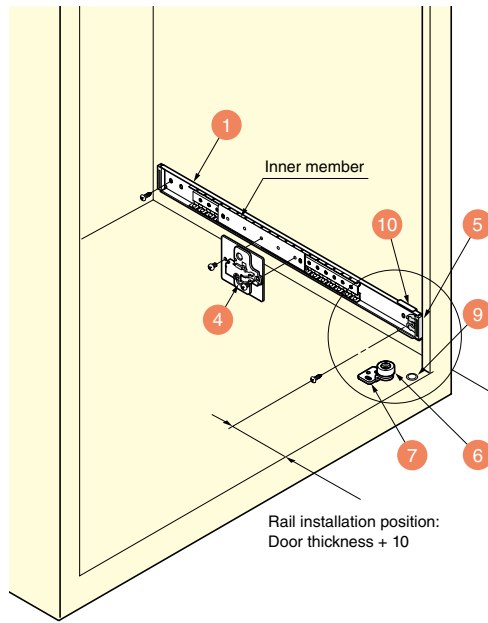

**Catch 5 (AL127-CH)**

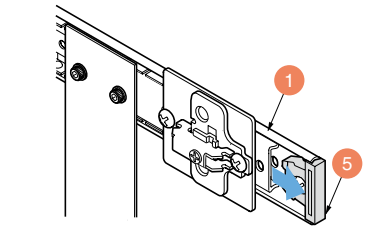

**Installation of Catch 5**

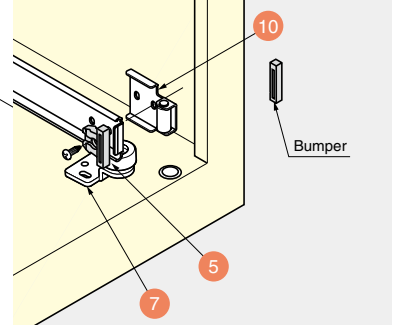

Remove bumpers from the lower two rails, and replace with the catches 5. If the number of rail is two (S type), replace on the lower rail only.

**Installation of Bracket 11**

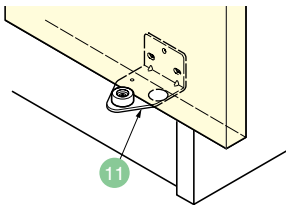

**Installation dimensions of bracket 11**

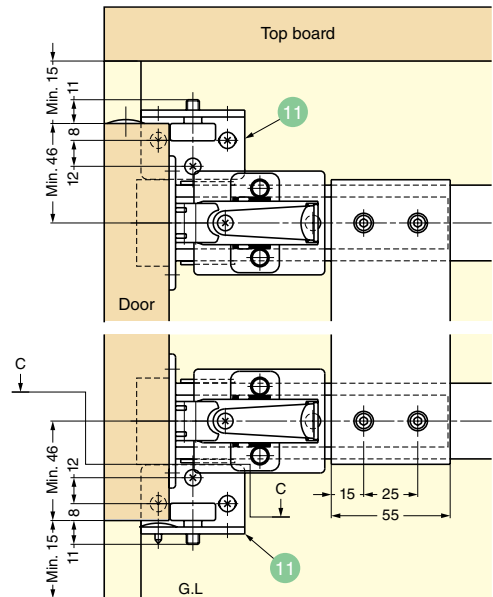

**Installation of Slider 9**

(Section C-C)

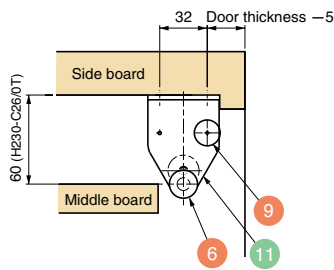

Right side installation

**Installation of Connecting Plate**

- Mount the connecting plate on the rails temporarily.
- Make sure that the connecting plate moves smoothly.
- Tighten the screws of the connecting plate.

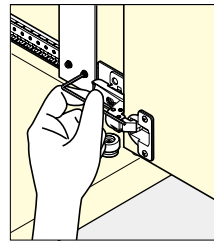
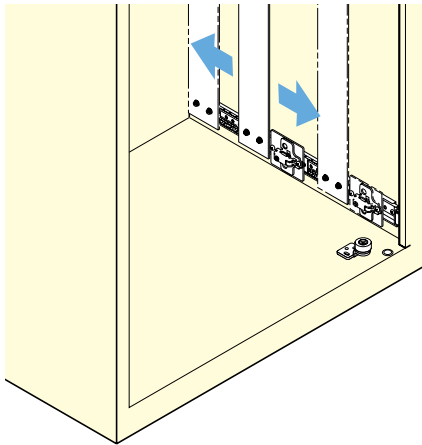

**Hanging Door**

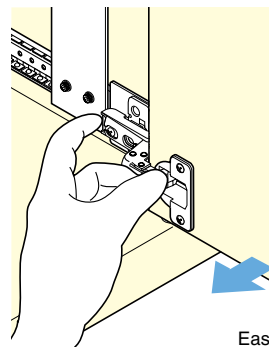
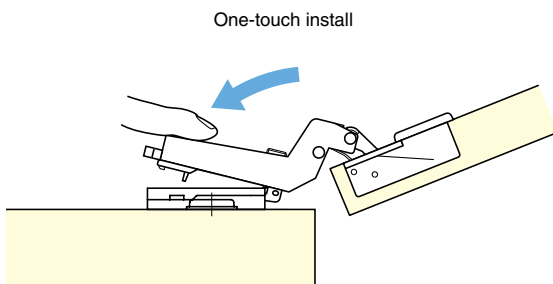

Easy to remove.

**Door Adjustment**

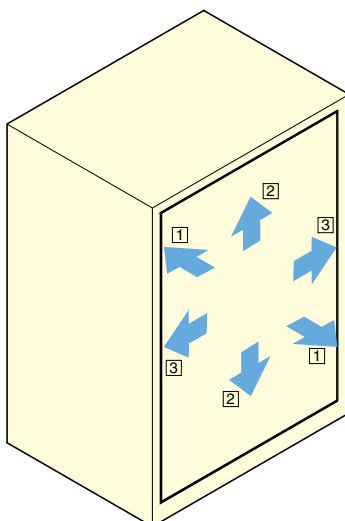

- 1 Front/Back adjustment
- 2 Height adjustment
- 3 Left/Right adjustment

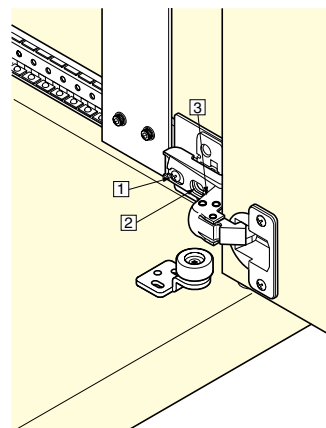

# POCKET DOOR SYSTEM (OVERLAY)



## ALT-2V-5

WARDROBE & CABINET DOOR HARDWARE

POCKET DOOR SYSTEM (OVERLAY)



| Item Name      | ALT-2V-5S-16 - 28<br>S Type<br>(2 Rails) | ALT-2V-5M16 - 28<br>M Type<br>(3 Rails) | ALT-2V-5L-16 - 28<br>L Type<br>(3 Rails) | ALT-2V-5LL-16 - 28<br>LL Type<br>(4 Rails) |
|----------------|--|---|--|--|
| Door Width     | Max. 560 mm                              | Max. 560 mm                             | Max. 560 mm                              | Max. 600 mm                                |
| Door Height    | 830 - 1060 mm                            | 1250 - 1500 mm                          | 1650 - 1840 mm                           | 1990 - 2300 mm                             |
| Door Thickness | Max. 20 mm                               |   |  |  |
| Door Weight    | Max. 5 kg                                | Max. 6 kg                               | Max. 8 kg                                | Max. 10 kg                                 |

### Features

- Works on cabinet doors up to 2300mm in height and 600mm wide.
- Works on many sizes of horizontal opening cabinet doors. Designed for overlay pocket doors.
- When open, doors can retract inside the cabinet, allowing full access (besides pocket) to inside of cabinet.
- Movement is extremely smooth due to slide rails.
- Uses a snap-in type concealed hinge for easy attachment and removal.

### Remarks

For wooden door only.

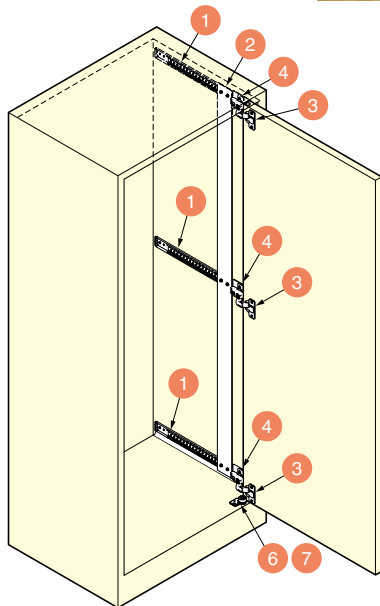
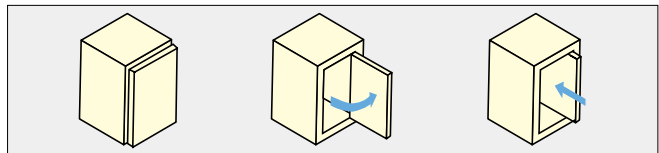

### Door Cut Out Dimensions

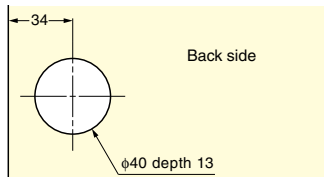

### Installation

### Rail Installation and Clearance Dimensions

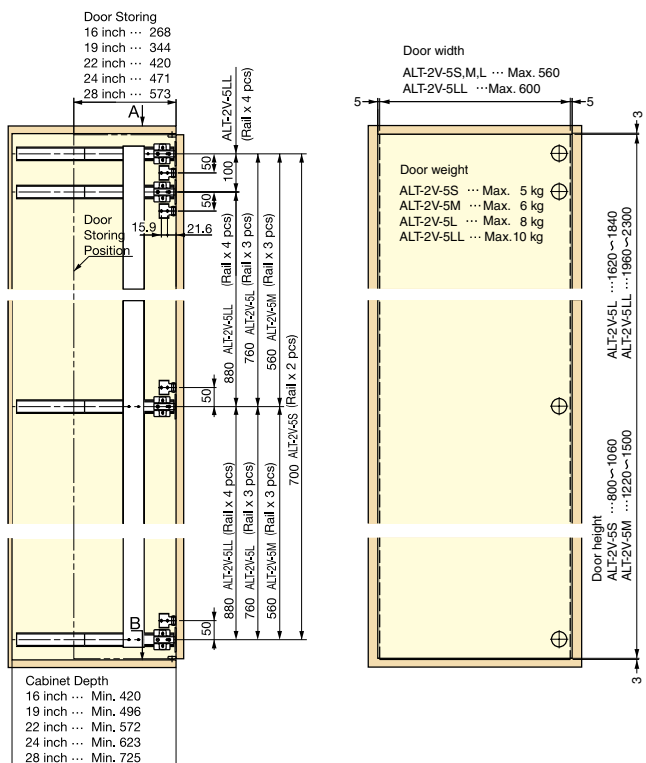
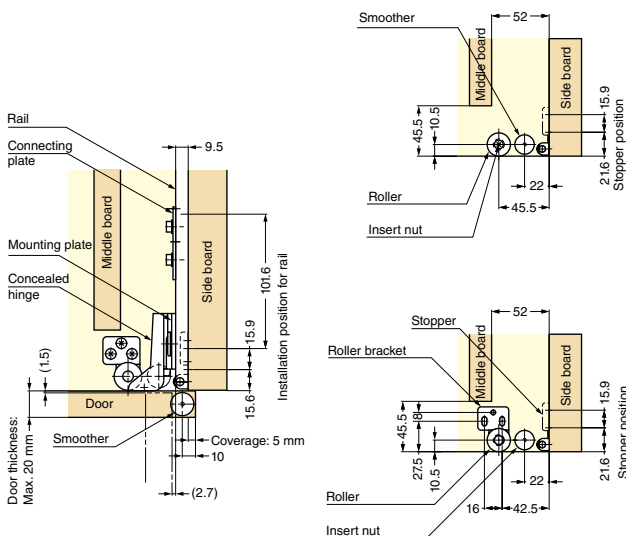





| Parts Set (Per Door) |             |               | Necessary Parts |       |                    |      |                          |       |                  |       |                  |       |
|----------------------|-------------|---------------|-----------------|-------|--------------------|------|--------------------------|-------|------------------|-------|------------------|-------|
| Type                 | Item Code   | Item Name     | Part Name       |       |                    |      |                          |       |                  |       |                  |       |
|                      |             |               | 1 Rail          |       | 2 Connecting Plate |      | 3 Concealed Hinge (Body) |       | 4 Mounting Plate |       | 5 - 11 Parts Set |       |
|                      |             |               | Item Name       | Qty   | Item Name          | Qty  | Item Name                | Qty   | Item Name        | Qty   | Item Name        | Qty   |
| S                    | 180-120-910 | ALT-2V-5S-16  | AL127C-16       | 2 pcs | ALT55-S            | 1 pc | 51-MH45-05-15            | 2 pcs | 520401M5020      | 2 pcs | ALT-2V-5SP       | 1 set |
|                      | 180-120-911 | ALT-2V-5S-19  | AL127C-19       | 2 pcs | ALT55-S            | 1 pc | 51-MH45-05-15            | 2 pcs | 520401M5020      | 2 pcs | ALT-2V-5SP       | 1 set |
|                      | 180-120-912 | ALT-2V-5S-22  | AL127C-22       | 2 pcs | ALT55-S            | 1 pc | 51-MH45-05-15            | 2 pcs | 520401M5020      | 2 pcs | ALT-2V-5SP       | 1 set |
|                      | 180-120-913 | ALT-2V-5S-24  | AL127C-24       | 2 pcs | ALT55-S            | 1 pc | 51-MH45-05-15            | 2 pcs | 520401M5020      | 2 pcs | ALT-2V-5SP       | 1 set |
|                      | 180-120-914 | ALT-2V-5S-28  | AL127C-28       | 2 pcs | ALT55-S            | 1 pc | 51-MH45-05-15            | 2 pcs | 520401M5020      | 2 pcs | ALT-2V-5SP       | 1 set |
| M                    | 180-120-915 | ALT-2V-5M-16  | AL127C-16       | 3 pcs | ALT55-M            | 1 pc | 51-MH45-05-15            | 3 pcs | 520401M5020      | 3 pcs | ALT-2V-5MP       | 1 set |
|                      | 180-120-916 | ALT-2V-5M-19  | AL127C-19       | 3 pcs | ALT55-M            | 1 pc | 51-MH45-05-15            | 3 pcs | 520401M5020      | 3 pcs | ALT-2V-5MP       | 1 set |
|                      | 180-120-917 | ALT-2V-5M-22  | AL127C-22       | 3 pcs | ALT55-M            | 1 pc | 51-MH45-05-15            | 3 pcs | 520401M5020      | 3 pcs | ALT-2V-5MP       | 1 set |
|                      | 180-120-918 | ALT-2V-5M-24  | AL127C-24       | 3 pcs | ALT55-M            | 1 pc | 51-MH45-05-15            | 3 pcs | 520401M5020      | 3 pcs | ALT-2V-5MP       | 1 set |
|                      | 180-120-919 | ALT-2V-5M-28  | AL127C-28       | 3 pcs | ALT55-M            | 1 pc | 51-MH45-05-15            | 3 pcs | 520401M5020      | 3 pcs | ALT-2V-5MP       | 1 set |
| L                    | 180-120-920 | ALT-2V-5L-16  | AL127C-16       | 3 pcs | ALT55-L            | 1 pc | 51-MH45-05-15            | 3 pcs | 520401M5020      | 3 pcs | ALT-2V-5LP       | 1 set |
|                      | 180-120-921 | ALT-2V-5L-19  | AL127C-19       | 3 pcs | ALT55-L            | 1 pc | 51-MH45-05-15            | 3 pcs | 520401M5020      | 3 pcs | ALT-2V-5LP       | 1 set |
|                      | 180-120-922 | ALT-2V-5L-22  | AL127C-22       | 3 pcs | ALT55-L            | 1 pc | 51-MH45-05-15            | 3 pcs | 520401M5020      | 3 pcs | ALT-2V-5LP       | 1 set |
|                      | 180-120-923 | ALT-2V-5L-24  | AL127C-24       | 3 pcs | ALT55-L            | 1 pc | 51-MH45-05-15            | 3 pcs | 520401M5020      | 3 pcs | ALT-2V-5LP       | 1 set |
|                      | 180-120-924 | ALT-2V-5L-28  | AL127C-28       | 3 pcs | ALT55-L            | 1 pc | 51-MH45-05-15            | 3 pcs | 520401M5020      | 3 pcs | ALT-2V-5LP       | 1 set |
| LL                   | 180-120-925 | ALT-2V-5LL-16 | AL127C-16       | 4 pcs | ALT55-LL           | 1 pc | 51-MH45-05-15            | 4 pcs | 520401M5020      | 4 pcs | ALT-2V-5LLP      | 1 set |
|                      | 180-120-926 | ALT-2V-5LL-19 | AL127C-19       | 4 pcs | ALT55-LL           | 1 pc | 51-MH45-05-15            | 4 pcs | 520401M5020      | 4 pcs | ALT-2V-5LLP      | 1 set |
|                      | 180-120-927 | ALT-2V-5LL-22 | AL127C-22       | 4 pcs | ALT55-LL           | 1 pc | 51-MH45-05-15            | 4 pcs | 520401M5020      | 4 pcs | ALT-2V-5LLP      | 1 set |
|                      | 180-120-928 | ALT-2V-5LL-24 | AL127C-24       | 4 pcs | ALT55-LL           | 1 pc | 51-MH45-05-15            | 4 pcs | 520401M5020      | 4 pcs | ALT-2V-5LLP      | 1 set |
|                      | 180-120-929 | ALT-2V-5LL-28 | AL127C-28       | 4 pcs | ALT55-LL           | 1 pc | 51-MH45-05-15            | 4 pcs | 520401M5020      | 4 pcs | ALT-2V-5LLP      | 1 set |

| Optional Parts |                              |      |                       |                    |            |  |
|----------------|------------------------------|------|-----------------------|--------------------|------------|--|
| No.            | Installation Position        | Qty  | Item Code             | Part Name          | Dimensions | Description  |
| 12             | For Lower Right & Upper Left | 1 pc | 180-120-342           | Side Mount Bracket |            | <ul style="list-style-type: none"> <li>Material: Steel</li> <li>Finish: Yellow Zinc Chromate</li> </ul> See P.612 for details. |
|                |                              |      | Item Name: ALT-2V5BR1 |                    |            |  |
| 13             | For Upper Right & Lower Left | 1 pc | 180-120-343           |                    |            |  |
|                |                              |      | Item Name: ALT-2V5BR2 |                    |            |  |

# ALT-2V-5 PARTS SET DETAILS

WARDROBE & CABINET DOOR HARDWARE

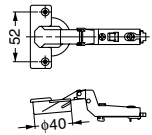
POCKET DOOR SYSTEM (OVERLAY)

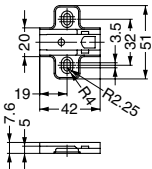
| No. | Qty   |       |       |       | Part Name  | Dimensions   | Description  |
|-----|-------|-------|-------|-------|--|--|--|
|     | S     | M     | L     | LL    |  |  |  |
| 1   | 2 pcs | 3 pcs | 3 pcs | 4 pcs | Rail<br>                    | See Rail Dimensions.   | Item Code : 190-113-867<br>Item Name : AL127C-16<br><br>Item Code : 190-113-868<br>Item Name : AL127C-19<br><br>Item Code : 190-113-869<br>Item Name : AL127C-22<br><br>Item Code : 190-113-870<br>Item Name : AL127C-24<br><br>Item Code : 190-113-871<br>Item Name : AL127C-28<br><br>• Material<br>Steel<br>• Finish<br>Clear Zinc Chromate |
| 2   | 1 pc  | 1 pc  | 1 pc  | 1 pc  | Connecting Plate<br>        | See Connecting Plate Dimensions.   | Item Code : 180-120-526<br>Item Name : ALT55-S<br><br>Item Code : 180-120-525<br>Item Name : ALT55-M<br><br>Item Code : 180-120-524<br>Item Name : ALT55-L<br><br>Item Code : 180-120-523<br>Item Name : ALT55-LL<br><br>• Material<br>Aluminium Alloy<br>• Finish<br>Plain  |
| 3   | 2 pcs | 3 pcs | 3 pcs | 4 pcs | Concealed Hinge (Body)<br> |  | Item Code : 160-070-006<br>Item Name : 51-MH45-05-15<br><br>• Material<br>Steel<br>• Finish<br>Nickel<br><br>w/ Catch  |
| 4   | 2 pcs | 3 pcs | 3 pcs | 4 pcs | Mounting Plate<br>        |  | Item Code : 160-076-076<br>Item Name : 520401M5020<br><br>• Material<br>Steel<br>• Finish<br>Nickel  |

• Rail Dimensions

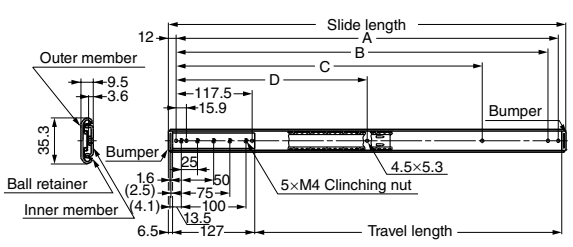

| Item Name | Slide Length | Travel Length | Door Storage | A     | B     | C     | D     |
|-----------|--------------|---------------|--------------|-------|-------|-------|-------|
| AL127C-16 | 411.4        | 269.4         | 268          | 387.4 | 371.5 | 269.9 | -     |
| AL127C-19 | 487.6        | 345.6         | 344          | 463.6 | 447.7 | 346.1 | 231.8 |
| AL127C-22 | 563.8        | 421.8         | 420          | 539.8 | 523.9 | 422.3 | 269.9 |
| AL127C-24 | 614.6        | 472.6         | 471          | 590.6 | 574.7 | 473.1 | 295.3 |
| AL127C-28 | 716.2        | 574.2         | 573          | 692.2 | 676.3 | 574.7 | 346.1 |

• Connecting Plate Dimensions

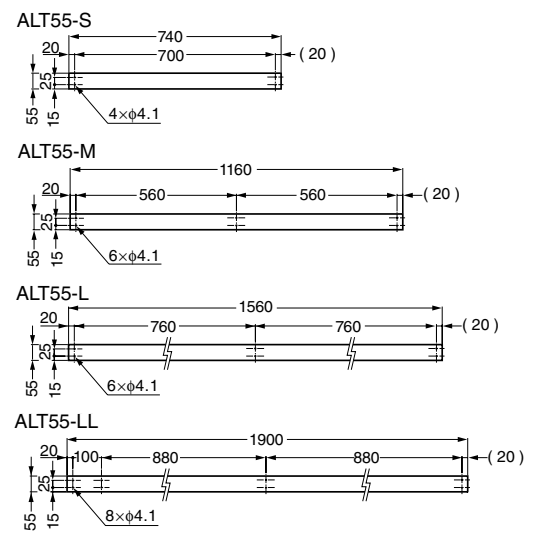

Parts Set Details

- a Item Code: 180-120-344 Item Name: ALT-2V-5SP
- b Item Code: 180-120-345 Item Name: ALT-2V-5MP
- c Item Code: 180-120-346 Item Name: ALT-2V-5LP
- d Item Code: 180-120-347 Item Name: ALT-2V-5LLP

| No. | Qty                     |                         |                         |                         | Part Name   | Dimensions   | Description   |
|-----|-------------------------|-------------------------|-------------------------|-------------------------|---|--|---|
|     | a                       | b                       | c                       | d                       |   |  |   |
| 5   | 1 pc                    | 2 pcs                   | 2 pcs                   | 2 pcs                   |    |  <p>29.4, 6.5, (5.5), 23.2, (19.2), <math>\phi 4.5</math> <math>\phi 9.2</math> depth 5.6, 1.6, 7.2</p>                            | <p><b>Item Code : 180-120-522</b><br/> <b>Item Name : AL127-CH</b></p> <ul style="list-style-type: none"> <li>• Material PUR</li> <li>• Finish Black</li> </ul>   |
| 6   | 2 pcs                   | 2 pcs                   | 2 pcs                   | 2 pcs                   |    |  <p><math>\phi 21</math>, 1, M6, <math>\phi 8</math>, <math>\phi 12</math>, 9, 8, 2.5</p>  | <p><b>Item Code : 180-940-144</b><br/> <b>Item Name : DU19-B4SBR</b></p> <ul style="list-style-type: none"> <li>• Material EPDM / Steel</li> <li>• Finish Clear Zinc Chromate / White</li> </ul>  |
| 7   | 1 pair (Left and Right) | 1 pair (Left and Right) | 1 pair (Left and Right) | 1 pair (Left and Right) |   |  <p><math>\phi 4.2</math>, 2x4.2x8.2, 6, 1.9, 1.9, M6, 21, 7.5, 18, 3</p> <p>Letter stamped indicates type (ALT-2V-AB shown).</p> | <p><b>Item Code : 180-930-145</b><br/> <b>Item Name : ALT-2V-AB</b></p> <p><b>Item Code : 180-930-146</b><br/> <b>Item Name : ALT-2V-BB</b></p> <ul style="list-style-type: none"> <li>• Material Steel</li> <li>• Finish Yellow Zinc Chromate</li> </ul> |
| 8   | 2 pcs                   | 2 pcs                   | 2 pcs                   | 2 pcs                   |  |  <p>M6, <math>\phi 11</math>, 13, <math>\phi 9</math></p>   | <p><b>Item Code : 120-041-310</b><br/> <b>Item Name : SC-107-13</b></p> <ul style="list-style-type: none"> <li>• Material PA</li> <li>• Finish White</li> </ul>   |
| 9   | 2 pcs                   | 2 pcs                   | 2 pcs                   | 2 pcs                   |  |  <p><math>\phi 17.5</math>, 9, 1.8, <math>\phi 3</math></p>   | <p><b>Item Code : 210-030-123</b><br/> <b>Item Name : G-175</b></p> <ul style="list-style-type: none"> <li>• Material PE</li> <li>• Finish Natural</li> </ul>   |
| 10  | 2 pcs                   | 3 pcs                   | 3 pcs                   | 4 pcs                   |  |  <p>2xM4, 2x<math>\phi 4.1</math>, 19, 7.5, 42, 3.2</p>  | <p><b>Item Code : 180-920-308</b><br/> <b>Item Name : ALT-2V5P</b></p> <ul style="list-style-type: none"> <li>• Material Steel</li> <li>• Finish Yellow Zinc Chromate</li> </ul>  |
| 11  | 2 pcs                   | 3 pcs                   | 3 pcs                   | 4 pcs                   |  |  <p>6, 43, 37.5, 15.9, 11.5, 5.6, 35.6, 25, 2x<math>\phi 6.5</math>, 0.9.8</p>   | <p><b>Item Code : 180-930-416</b><br/> <b>Item Name : ALT-AD</b></p> <ul style="list-style-type: none"> <li>• Material UR / Steel</li> <li>• Finish Clear Zinc Chromate / White</li> </ul>  |

Parts Included

Hex key, Pan head screw M4x6, Binding head tapping screw, Countersunk head tapping screw, Hexagon top bolt M4x6, Countersunk head screw M4x6

WARDROBE & CABINET DOOR HARDWARE

POCKET DOOR SYSTEM (OVERLAY)

**Temporary Installation of Rail ①**

- Fix ⑪.
- Fix ① with ⑤.
- Fix ⑩ and ④ onto Inner member of ①.
- Attach ⑤ to ① as per the drawing on the right.

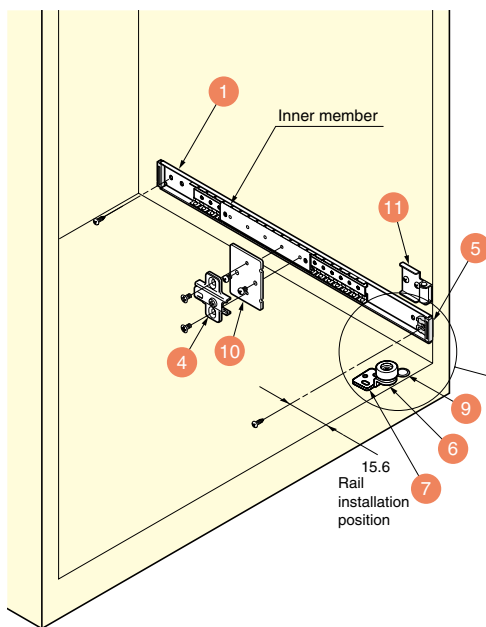

**Catch ⑤ (AL127-CH)**

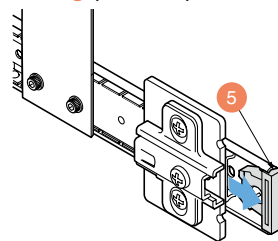

**Installation of Catch ⑤**

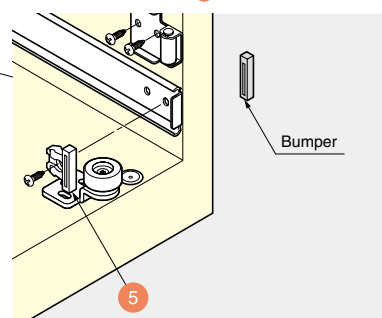

Remove the bumpers from the lower two rails, and replace with the catches ⑤. If the number of rail is two (S type), replace on the lower rail only.

**Installation of Side Mount Bracket ⑫ ⑬**

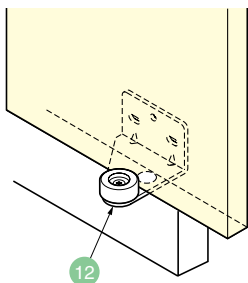

**Installation of Slider ⑨**

(Section C-C)

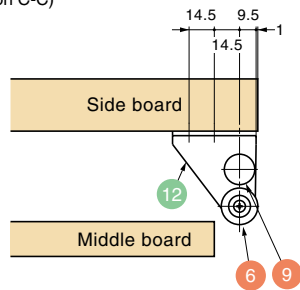

Right side installation

**Installation dimensions of side mount bracket ⑫ ⑬**

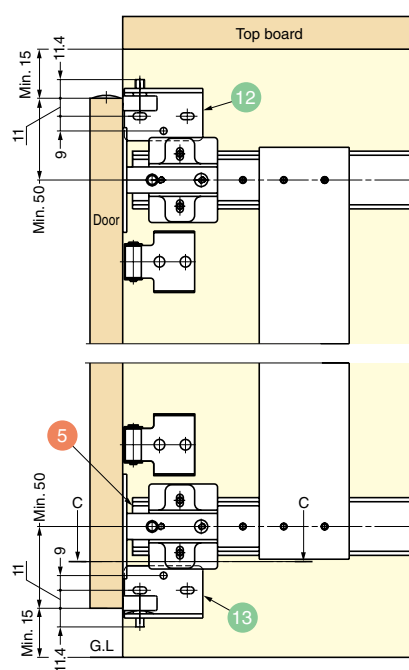



**Installation of Connecting Plate 2**

- Mount the connecting plate on the rails temporarily.
- Make sure that the connecting plate moves smoothly.
- Tighten the screws of the connecting plate.

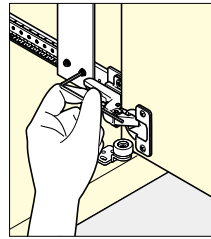
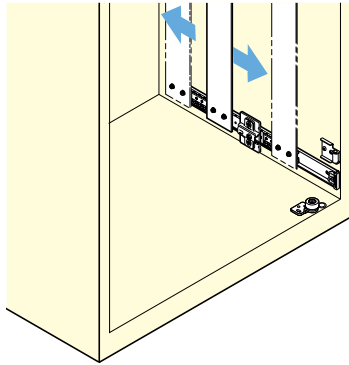

**Hanging Door**

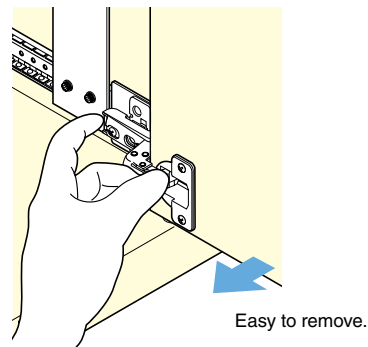
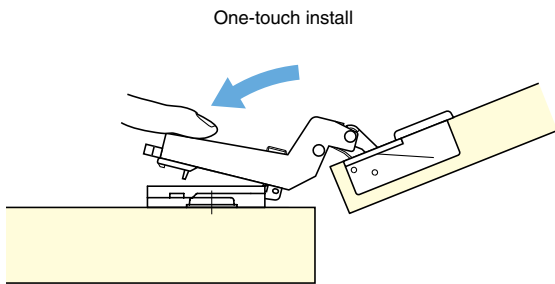

**Door Adjustment**

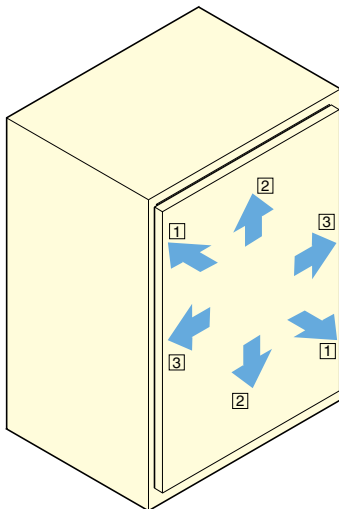

- 1 Front/Back adjustment
- 2 Height adjustment
- 3 Left/Right adjustment

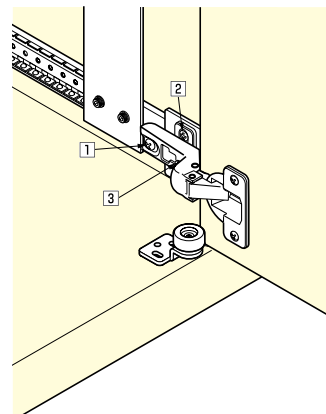

# FOLDING POCKET DOOR SYSTEM (INSET)



ALT-F

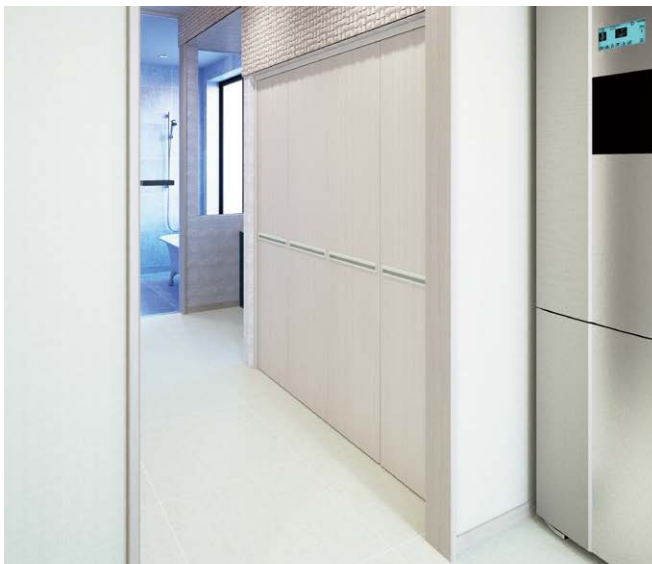

|                |                 |
|----------------|-----------------|
| Door Width     | Max. 450 mm     |
| Door Height    | Max. 1830 mm    |
| Door Thickness | 23 - 30 mm      |
| Door Weight    | Max. 10 kg/Door |

By using additional parts, Door Height Max 2400mm(Max 10kg/Door) possible. Please contact us for the details.

### Features

- Combines folding doors for wider door spaces.
- Folding doors retract into cabinet interior, full access (besides pocket) to the interior.
- Great solution for home and residential in-suite storage including laundry rooms.
- Max door height: Up to 2400mm with 3 rails (1830mm with 2)
- Max door width: 450mm per door. 2 doors per folding side. Total 1800mm wide cabinet entrance.

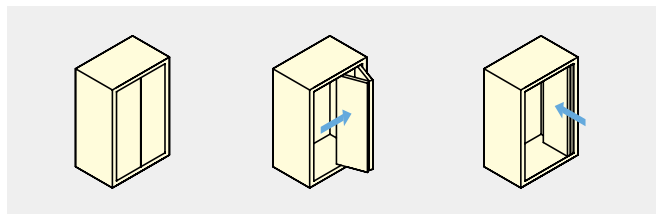

### Top View

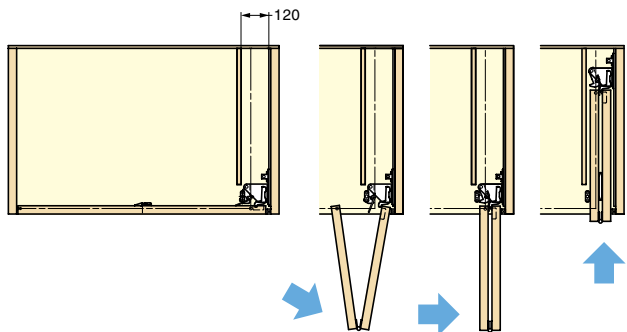

### Rail Dimensions

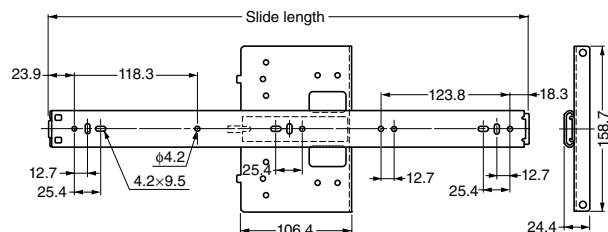

### Installation

Door storing  
355.6(ALT-F18)  
406.4(ALT-F20)

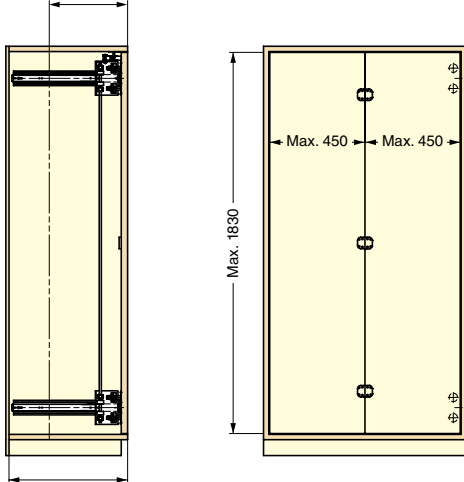

Min. cabinet depth  
Min. 466.7 + Door thickness (ALT-F18)  
Min. 517.5 + Door thickness (ALT-F20)

| Item Name | Opening       | Rail Length | Door Storing | Cabinet Depth               |
|-----------|---------------|-------------|--------------|-----------------------------|
| ALT-F18L  | Left Opening  | 460.4       | 355.6        | Min. 466.7 + Door Thickness |
| ALT-F18R  | Right Opening | 460.4       | 355.6        | Min. 466.7 + Door Thickness |
| ALT-F20L  | Left Opening  | 511.2       | 406.4        | Min. 517.5 + Door Thickness |
| ALT-F20R  | Right Opening | 511.2       | 406.4        | Min. 517.5 + Door Thickness |

WARDROBE & CABINET DOOR HARDWARE

FOLDING POCKET DOOR SYSTEM (INSET)

| Parts Set   |             | Necessary Parts |  |
|---|-------------|-----------------|--|
| Please refer to "Qty [a] - [d]" for parts included in each set. |             |                 |  |
| Set Name  | Item Code   | Item Name       |  |
| a Left Opening (Door Storing 355.6)                             | 180-034-183 | ALT-F18L        |  |
| b Right Opening (Door Storing 355.6)                            | 180-034-184 | ALT-F18R        |  |
| c Left Opening (Door Storing 406.4)                             | 180-034-185 | ALT-F20L        |  |
| d Right Opening (Door Storing 406.4)                            | 180-034-186 | ALT-F20R        |  |

Parts Included

| No. | Qty   | Part Name                             | Dimensions | Description  |
|-----|-------|---------------------------------------|------------|--|
| 1   | 2 pcs | Rail                                  | See P.614  | <ul style="list-style-type: none"> <li>Material Steel</li> <li>Finish Black Chromate</li> </ul>                                      |
| 2   | 2 pcs | Rack                                  |            | <ul style="list-style-type: none"> <li>Material ABS</li> <li>Finish Black</li> </ul>   |
| 3   | 1 pc  | Cap                                   |            | <ul style="list-style-type: none"> <li>Material Steel</li> <li>Finish Black Chromate</li> </ul>                                      |
| 4   | 4 pcs | Gear                                  |            | <ul style="list-style-type: none"> <li>Material POM</li> <li>Finish Black</li> </ul>   |
| 5   | 4 pcs | Bush                                  |            | <ul style="list-style-type: none"> <li>Material POM</li> <li>Finish Black</li> </ul>   |
| 6   | 4 pcs | Stationary Block                      |            | <ul style="list-style-type: none"> <li>Material POM</li> <li>Finish Black</li> </ul> Screw : Binding Head Self Tapping Screw UNC8-32 |
| 7   | 2 pcs | Not for ALT-F. This part is not used. |            | <ul style="list-style-type: none"> <li>Material PA</li> <li>Finish Black</li> </ul> Screw : Countersunk Head Tapping Screw 4.2x32    |
| 8   | 1 pc  | Upper Rail Joint                      |            | <ul style="list-style-type: none"> <li>Material POM</li> <li>Finish White</li> </ul>   |
| 9   | 1 pc  | End Guide                             |            | <ul style="list-style-type: none"> <li>Material Steel (SPCC) / POM</li> <li>Finish Yellow Zinc Chromate / Natural</li> </ul>         |
| 10  | 1 pc  | Angle Stopper                         |            | <ul style="list-style-type: none"> <li>Material Steel (SPCC)</li> <li>Finish Nickel</li> </ul>                                       |

| No. | Qty           | Part Name           | Dimensions | Description  |
|-----|---------------|---------------------|------------|--|
| 11  | 1 pc          | Inner Guide         |            | <ul style="list-style-type: none"> <li>Material POM</li> <li>Finish White</li> </ul>   |
| 12  | 1 pc          | Interlock           |            | <ul style="list-style-type: none"> <li>Material Steel / POM</li> <li>Finish Black / White</li> </ul> Right type shown.   |
| 13  | 3 pcs         | Centre Hinge        |            | <ul style="list-style-type: none"> <li>Material Steel</li> <li>Finish Black</li> </ul> Screw : Countersunk Head Tapping Screw 3.5x16   |
| 14  | 1 pc          | Hinge Cover Bracket |            | <ul style="list-style-type: none"> <li>Material Steel (SPCC)</li> <li>Finish Black Paint</li> </ul>  |
| 15  | 2 set (4 pcs) | Hinge Set           |            | Item Code : 180-026-432<br>Item Name : ALT-F-8086HKEZX<br><ul style="list-style-type: none"> <li>Material Steel / Zinc Alloy</li> <li>Finish Yellow Zinc Chromate / Black</li> </ul> |

| Rail |      | Necessary Parts                        |                             |            |   |
|------|------|--|-----------------------------|------------|---|
|      |      | 1 pc is necessary for a pair of doors. |                             |            |   |
| No.  | Qty  | Item Code                              | Part Name                   | Dimensions | Description   |
| 16   | 1 pc | 250-017-148                            | Upper Rail (1820 mm)        |            | <ul style="list-style-type: none"> <li>Material Aluminium</li> <li>Finish Anodized Silver</li> </ul> Bore Pitch : Approx. 300 mm<br>Pitch End : Approx. 30 mm |
| 17   | 1 pc | 250-019-971                            | Bottom Guide Rail (1500 mm) |            | <ul style="list-style-type: none"> <li>Material Aluminium</li> <li>Finish Anodized Silver</li> </ul>  |

| Shaft |            | Necessary Parts                        |                    |                    |            |   |
|-------|------------|--|--------------------|--------------------|------------|---|
|       |            | 1 pc is necessary for a pair of doors. |                    |                    |            |   |
| No.   | Length     | Qty                                    | Item Code          | Part Name          | Dimensions | Description   |
| 18    | 902±13 mm  | 1 pc                                   | 180-121-047        | Shaft              |            | <ul style="list-style-type: none"> <li>Material Steel</li> <li>Finish Black Chromate</li> </ul> |
|       |            |  | Item Name 29475-36 |                    |            |   |
| 19    | 1207±13 mm | 1 pc                                   | 180-121-048        | Item Name 29475-48 |            |   |
|       |            |  | Item Name 29475-72 |                    |            |   |

WARDROBE & CABINET DOOR HARDWARE

FOLDING POCKET DOOR SYSTEM (INSET)

# POCKET DOOR SYSTEM (INSET)



## TSSL-2V

|             |                 |
|-------------|-----------------|
| Door Width  | Max. 800 mm     |
| Door Height | 1760 - 2300 mm  |
| Door Weight | Max. 20 kg/Door |

### Features

- Opening door is stored inside the cabinet.
- One touch door installation & removal.

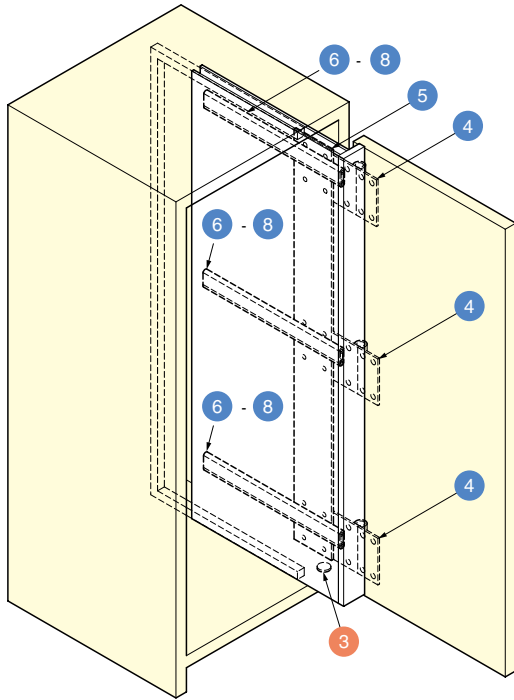
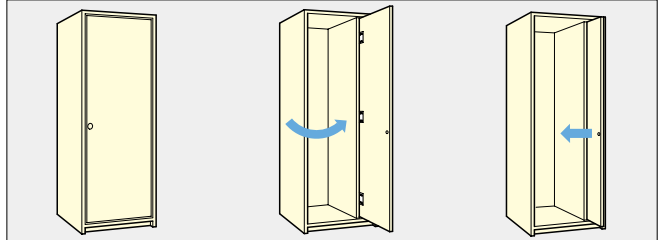

WARDROBE & CABINET DOOR HARDWARE

### Installation

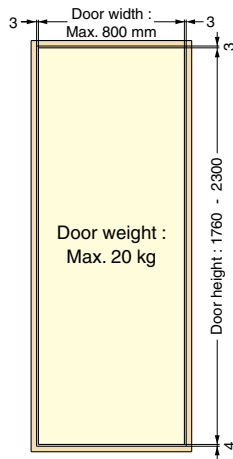
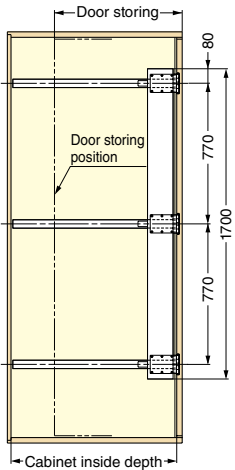

### Side view (Wooden door)

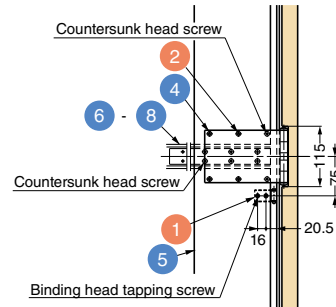

### Top view (Wooden door)

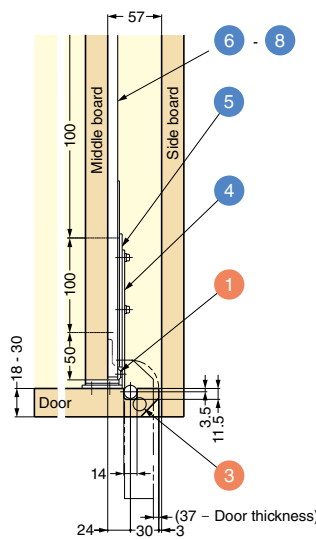

### Top view (Steel door)

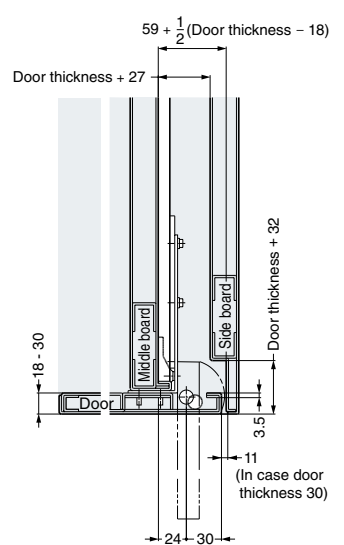

### Cut Out Dimensions

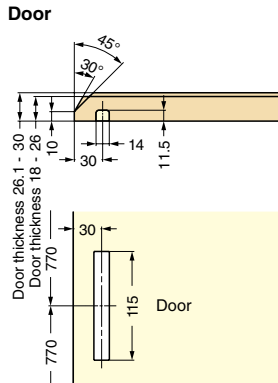

### Cabinet

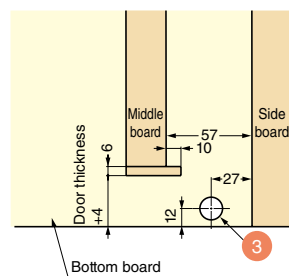

POCKET DOOR SYSTEM (INSET)

• Necessary Parts ..... **Parts Set** + **Hinge** + **Connecting Plate** + **Rails**

| Parts Set (Per Door) |             | Necessary Parts |  |
|----------------------|-------------|-----------------|--|
| Type                 | Item Code   | Item Name       |  |
| a) 600 mm Rails      | 180-110-575 | TSSL-2VD600     |  |
| b) 800 mm Rails      | 180-110-576 | TSSL-2VD800     |  |
| c) 900 mm Rails      | 180-110-577 | TSSL-2VD900     |  |

| Rail |                     | Necessary Parts                 |             |           |  |
|------|---------------------|---------------------------------|-------------|-----------|--|
|      |                     | 3 pcs are necessary for 1 door. |             |           |  |
| No.  | Type                | Qty                             | Item Code   | Part Name | Description  |
| 6    | Slide Length 600 mm | 1 pc                            | 190-110-570 | Rail      |  <p>* Material SUS304</p> |
|      |                     |                                 | TSSL-600SV  |           |  |
| 7    | Slide Length 800 mm | 1 pc                            | 190-110-571 | Rail      |  |
|      |                     |                                 | TSSL-800SV  |           |  |
| 8    | Slide Length 900 mm | 1 pc                            | 190-110-572 | Rail      |  |
|      |                     |                                 | TSSL-900SV  |           |  |

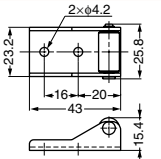
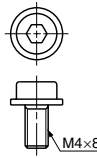
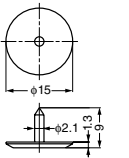
| No. | Qty    |        |        | Part Name    | Dimensions   | Description  |
|-----|--------|--------|--------|--------------|--|--|
|     | a      | b      | c      |              |  |  |
| 1   | 3 pcs  | 3 pcs  | 3 pcs  | Door Stopper |   | <ul style="list-style-type: none"> <li>Material Steel</li> <li>Finish Clear Zinc Chromate</li> </ul>                                       |
| 2   | 12 pcs | 12 pcs | 12 pcs | Bolt         |   | <ul style="list-style-type: none"> <li>Material Steel</li> <li>Finish Yellow Zinc Chromate</li> </ul>                                      |
| 3   | 1 pc   | 1 pc   | 1 pc   | Slider       |  | <p>Item Code : 210-030-122<br/>Item Name : F-15</p> <ul style="list-style-type: none"> <li>Material POM</li> <li>Finish Natural</li> </ul> |

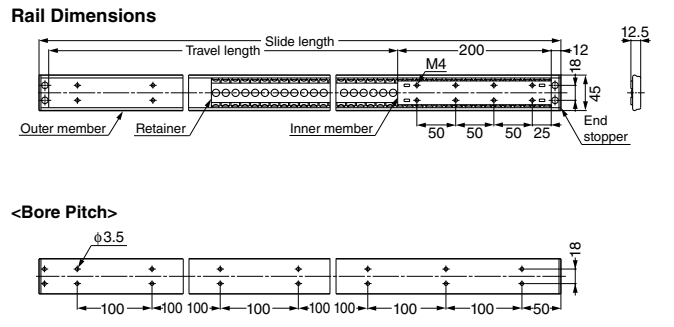

| Item Name  | Slide Length | Travel Length | Bore Qty N | Door Storage         | Depth Inside Cabinet |
|------------|--------------|---------------|------------|----------------------|----------------------|
| TSSL-600SV | 600          | 376           | 12         | 402.5+Door thickness | Min. 620             |
| TSSL-800SV | 800          | 576           | 16         | 602.5+Door thickness | Min. 820             |
| TSSL-900SV | 900          | 676           | 18         | 702.5+Door thickness | Min. 920             |

**Parts Included**  
 Binding head tapping screw 3.5x15..... a) 36 pcs, b) 48 pcs, c) 54 pcs  
 Countersunk head screw..... 24 pcs

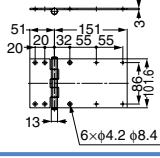
| Hinge |      | Necessary Parts                 |           |   |  |
|-------|------|---------------------------------|-----------|---|--|
|       |      | 3 pcs are necessary for 1 door. |           |   |  |
| No.   | Qty  | Item Code                       | Part Name | Dimensions  | Description  |
| 4     | 1 pc | 180-110-562                     | Hinge     |  | <ul style="list-style-type: none"> <li>Material Steel</li> <li>Finish White</li> </ul> |
|       |      | TSSL-2VH                        |           |   |  |

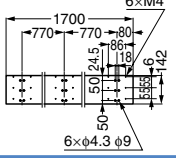
| Connecting Plate |      | Necessary Parts               |                  |   |   |
|------------------|------|-------------------------------|------------------|---|---|
|                  |      | 1 pc is necessary for 1 door. |                  |   |   |
| No.              | Qty  | Item Code                     | Part Name        | Dimensions  | Description   |
| 5                | 1 pc | 180-110-563                   | Connecting Plate |  | <ul style="list-style-type: none"> <li>Material Steel</li> <li>Finish Yellow Zinc Chromate</li> </ul> |
|                  |      | TSSL-2VP                      |                  |   |   |

WARDROBE & CABINET DOOR HARDWARE

POCKET DOOR SYSTEM (INSET)

# MULTIPLE MOTION DOOR SYSTEM (FOR WOOD PANELS)



Multiple Motion Door System

## MultiMo FLAT®

WARDROBE & CABINET DOOR HARDWARE



Mirror door can be used.

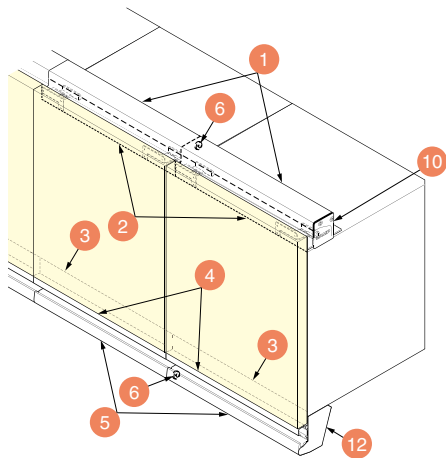

|                |   |
|----------------|---|
| Door Width     | 297 mm, 447 mm, 597 mm, 897 mm              |
| Door Height    | 300 - 900 mm                                |
| Door Thickness | 15 - 23 mm                                  |
| Door Weight    | 1.5 - 6.8 kg (Per One Door) *               |
| Door Type      | Connecting Multiple Sliding Units (Overlay) |

\*Including parts.

### Features

- Cabinet doors can be rearranged freely, like puzzle pieces.
- Sleek Appearance**  
All doors are flush with each other when closed. Visually appealing, consistent design.
- Interchangeable Door Position**  
Opened doors can slide and be repositioned anywhere where there is space on the supporting rails.
- Extendible**  
Multiple doors can be added by connecting multiple sliding units.
- Soft & Smooth Movement**  
Built in damper for soft and smooth closing movement.
- Small Space Required**  
Great solution for shallow cabinets, hardware requires only 80mm depth.

### Remarks

- Recommended using 3 or more doors for interchangeable door.
- Maximum door height is twice of door width.
- Glass door version is also available (P.620).  
(Wooden door and glass door models are not compatible within the same cabinet.)

Interchangeable door position (3 doors or more)

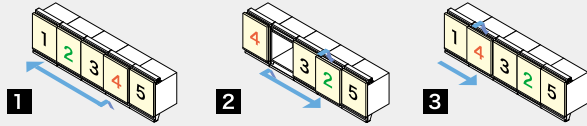

MULTIPLE MOTION DOOR SYSTEM

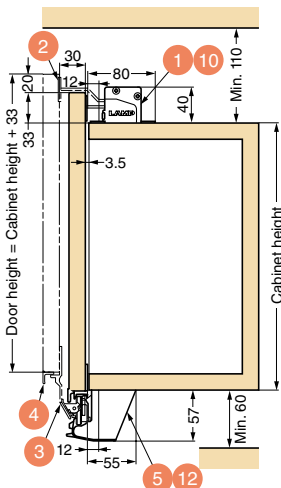

### Cut Out Dimensions for Door Brackets 2, Door Sliding Profile 3, Door Handle 4

- Door width 297 mm, 447 mm
- Door width 597 mm, 897 mm

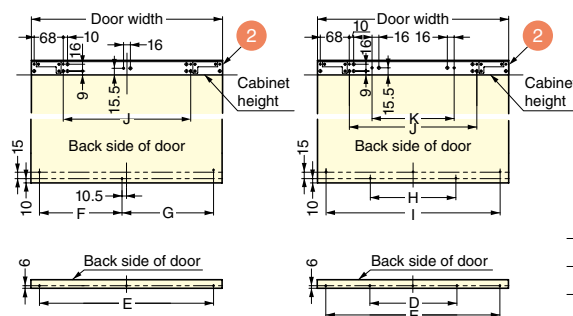

Door opening example (4 doors)

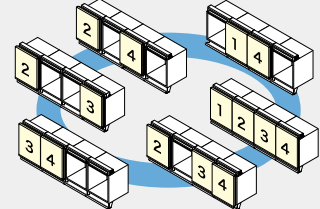

Provides various opening patterns. By adding more doors, the more opening patterns will be possible.

| Door Width | D     | E   | F   | G   | H   | I   | J   | K   |
|------------|-------|-----|-----|-----|-----|-----|-----|-----|
| 297        | -     | 257 | 118 | 139 | -   | -   | 148 | -   |
| 447        | -     | 407 | 193 | 214 | -   | -   | 298 | -   |
| 597        | 278.5 | 557 | -   | -   | 300 | 557 | 448 | 200 |
| 897        | 428.5 | 857 | -   | -   | 400 | 857 | 748 | 300 |



| Parts Set (Per Door)                                       |             | Necessary Parts<br>Same qty as door is necessary. Please order same model for a cabinet. |  |
|--|-------------|--|--|
| Set Name   | Item Code   | Item Name  |  |
| a) Parts Set (Door Width 297 mm, Door Weight 1.5 - 2.4 kg) | 250-121-211 | MFS-W300/S2  |  |
| b) Parts Set (Door Width 447 mm, Door Weight 1.4 - 2.3 kg) | 250-121-212 | MFS-W450/S2  |  |
| c) Parts Set (Door Width 447 mm, Door Weight 2.4 - 3.3 kg) | 250-121-213 | MFS-W450/S3  |  |
| d) Parts Set (Door Width 597 mm, Door Weight 2.2 - 3.1 kg) | 250-121-214 | MFS-W600/S3  |  |
| e) Parts Set (Door Width 597 mm, Door Weight 3.2 - 4.1 kg) | 250-121-215 | MFS-W600/S4  |  |
| f) Parts Set (Door Width 597 mm, Door Weight 4.2 - 5.1 kg) | 250-121-216 | MFS-W600/S5  |  |
| g) Parts Set (Door Width 897 mm, Door Weight 3.9 - 4.8 kg) | 250-121-217 | MFS-W900/S5  |  |
| h) Parts Set (Door Width 897 mm, Door Weight 4.9 - 5.8 kg) | 250-121-218 | MFS-W900/S6  |  |
| i) Parts Set (Door Width 897 mm, Door Weight 5.9 - 6.8 kg) | 250-121-219 | MFS-W900/S7  |  |

Parts Included

| No. | Qty             | Item Code                                    | Dimensions | Description   |
|-----|-----------------|--|------------|---|
| 1   | 1 pc            | Upper Rail                                   |            | <ul style="list-style-type: none"> <li>Material Aluminium Alloy /Steel</li> <li>Finish Anodized /Clear Zinc Chromate</li> </ul>   |
| 2   | 1 pc            | Door Brackets                                |            | <ul style="list-style-type: none"> <li>Material Steel/Elastomer (TPE)</li> <li>Finish Clear Zinc Chromate</li> </ul> <p>*( ) is for Door Width 597 mm, 897 mm.</p>  |
| 3   | 1 pc            | Door Sliding Profile                         |            | <ul style="list-style-type: none"> <li>Material Aluminium Alloy /Steel /Polyacetal (POM) /Polyurethane (PUR)</li> <li>Finish Anodized /Clear Zinc Chromate</li> </ul> <p>*( ) is for Door Width 597 mm, 897 mm.</p> |
| 4   | 1 pc            | Door Handle                                  |            | <ul style="list-style-type: none"> <li>Material Aluminium Alloy</li> <li>Finish Anodized</li> </ul> <p>*( ) is for Door Width 597 mm, 897 mm.</p>   |
| 5   | 1 pc            | Lower Rail                                   |            | <ul style="list-style-type: none"> <li>Material Aluminium Alloy /Steel /Polyacetal (POM)</li> <li>Finish Anodized /Clear Zinc Chromate</li> </ul> <p>*( ) is for Door Width 597 mm, 897 mm.</p>                     |
| 6   | 2 pcs           | Connecting Pin                               |            | <ul style="list-style-type: none"> <li>Material Stainless Steel</li> </ul>  |
| 7   | 11 pcs (12 pcs) | Binding Head Tapping Screw 3.5x15            |            | -   |
| 8   | 13 pcs (16 pcs) | Raised Countersunk Head Tapping Screw 3.5x14 |            | -   |

Qty: ( ) is for MFS-W600/S3, MFS-W600/S4, MFS-W600/S5, MFS-W900/S5, MFS-W900/S6 and MFS-W900/S7.

Mounting Application for Upper Rail 1

• Out side of top panel

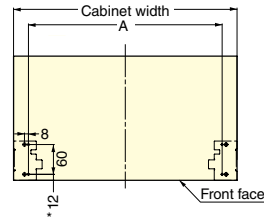

| Cabinet Width | A   |
|---------------|-----|
| 300           | 240 |
| 450           | 390 |
| 600           | 540 |
| 900           | 840 |

Mounting Application for Lower Rail 5

• Out side of bottom panel

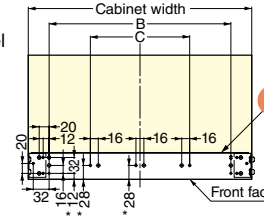

| Cabinet Width | B   | C   |
|---------------|-----|-----|
| 300           | 216 | -   |
| 450           | 366 | -   |
| 600           | 516 | 200 |
| 900           | 816 | 300 |

\*When using gasket thicker than 3 mm, subtract [gasket thickness - 3 mm] from the marked dimensions.

End Cap Set (Per Door) Necessary Parts 1 set is necessary for 1 unit.

| Set Name    | Item Code   | Item Name |
|-------------|-------------|-----------|
| End Cap Set | 250-129-555 | MFS-ED    |

Parts Included

| No. | Qty   | Item Code  | Dimensions | Description   |
|-----|-------|--|------------|---|
| 9   | 1 pc  | Connecting Plate   |            | <ul style="list-style-type: none"> <li>Material Steel</li> <li>Finish Grey</li> </ul> |
| 10  | 1 pc  | Installation Template  |            | <ul style="list-style-type: none"> <li>Material Steel</li> <li>Finish Grey</li> </ul> |
| 11  | 1 pc  | Left Upper Rail End Cap  |            | <ul style="list-style-type: none"> <li>Material ABS</li> <li>Finish Grey</li> </ul>   |
| 12  | 1 pc  | Right Upper Rail End Cap                                       |            | <ul style="list-style-type: none"> <li>Material ABS</li> <li>Finish Grey</li> </ul>   |
| 13  | 4 pcs | Raised Countersunk Head Tapping Screw 3.5x12 (Stainless Steel) |            | -   |

WARDROBE & CABINET DOOR HARDWARE

MULTIPLE MOTION DOOR SYSTEM

# MULTIPLE MOTION DOOR SYSTEM (FOR GLASS PANELS)

Multiple Motion Door System

## MultiMo FLAT®

WARDROBE & CABINET DOOR HARDWARE

FOR GLASS DOORS

MULTIPLE MOTION DOOR SYSTEM



Mirror door can be used.

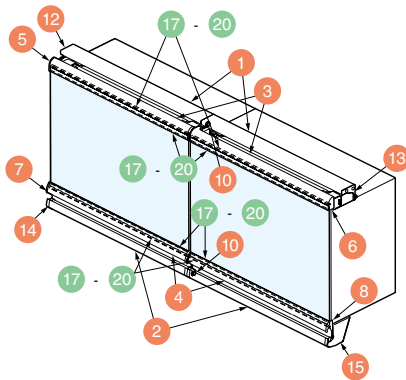

|                        |  |
|------------------------|--|
| <b>Glass Width</b>     | 295, 445, 595, *895 mm   |
| <b>Glass Height</b>    | 300 - 900 mm   |
| <b>Glass Thickness</b> | 5 mm   |
| <b>Door Weight</b>     | 1.5 - 6.7 kg (Per One Door)  |
| <b>Door Type</b>       | <input type="checkbox"/> Connecting Multiple Sliding Units (Overlay) |

\*When glass width is 895 mm, glass height is Max. 600 mm.

### Features

Cabinet doors can be rearranged freely, like puzzle pieces.

- Sleek Appearance  
All doors are flush with each other when closed. Visually appealing, consistent design.
- Interchangeable Door Position  
Opened doors can slide and be repositioned anywhere where there is space on the supporting rails.
- Extendible  
Multiple doors can be added by connecting multiple sliding units.
- Soft & Smooth Movement  
Built in damper for soft and smooth closing movement.
- Small Space Required  
Great solution for shallow cabinets, hardware requires only 84mm depth.

### Remarks

- Recommended using 3 or more doors for interchangeable door feature.
- Maximum door height is twice of door width.
- Wooden door version is also available (P.618).  
(Cannot be used together with wooden version on one cabinet.)

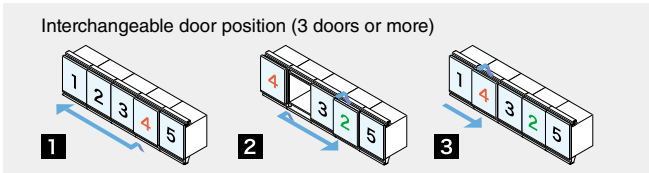

### Door opening example (4 doors)

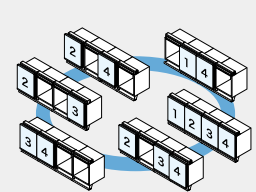

Provides various opening patterns. By adding more doors, the more opening patterns will be possible.

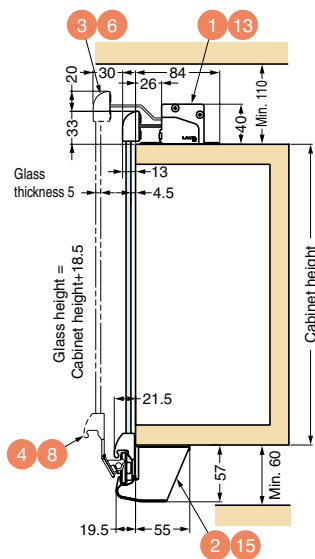

### Mounting Application for Upper Rail ①

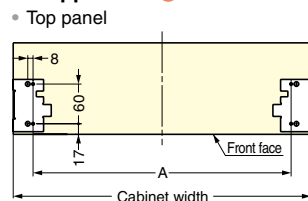

### Mounting Application for Lower Rail ②

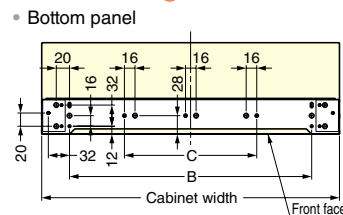

| Cabinet Width | A   | B   | C   |
|---------------|-----|-----|-----|
| 300           | 240 | 216 | -   |
| 450           | 390 | 366 | -   |
| 600           | 540 | 516 | 200 |
| 900           | 840 | 816 | 300 |



| Parts Set (Per Door)   |              | Necessary Parts<br>Same qty as door is necessary. Please order same model for a cabinet. |  |
|--|--------------|--|--|
| Set Name   | Item Code    | Item Name  |  |
| a) Parts Set (Glass Width 295 mm, Glass Weight 1.5 - 2.4 kg) | 250-014-166  | MFS-G300/S2  |  |
| b) Parts Set (Glass Width 445 mm, Glass Weight 1.3 - 2.2 kg) | 250-014-167  | MFS-G450/S2  |  |
| c) Parts Set (Glass Width 445 mm, Glass Weight 2.3 - 3.2 kg) | 250-014-168  | MFS-G450/S3  |  |
| d) Parts Set (Glass Width 595 mm, Glass Weight 2.1 - 3.0 kg) | 250-014-169  | MFS-G600/S3  |  |
| e) Parts Set (Glass Width 595 mm, Glass Weight 3.1 - 4.0 kg) | 250-014-170  | MFS-G600/S4  |  |
| f) Parts Set (Glass Width 595 mm, Glass Weight 4.1 - 5.0 kg) | 250-014-171  | MFS-G600/S5  |  |
| g) Parts Set (Glass Width 895 mm, Glass Weight 3.8 - 4.7 kg) | *250-014-172 | MFS-G900/S5  |  |
| h) Parts Set (Glass Width 895 mm, Glass Weight 4.8 - 5.7 kg) | *250-014-173 | MFS-G900/S6  |  |
| i) Parts Set (Glass Width 895 mm, Glass Weight 5.8 - 6.7 kg) | *250-014-174 | MFS-G900/S7  |  |

Parts Included

| No.                                     | Qty   | Part Name                   | Dimensions | Description  |
|---|-------|-----------------------------|------------|--|
| 1                                       | 1 pc  | Upper Rail                  |            | <ul style="list-style-type: none"> <li>Material Aluminium Alloy/Steel</li> <li>Finish Anodized /Clear Zinc Chromate</li> </ul>                   |
| 2                                       | 1 pc  | Lower Rail                  |            | <ul style="list-style-type: none"> <li>Material Aluminium Alloy/Steel /Polyacetal (POM)</li> <li>Finish Anodized /Clear Zinc Chromate</li> </ul> |
| *( ) is for Glass Width 595 mm, 895 mm. |       |                             |            |  |
| 3                                       | 1 pc  | Upper Door Frame            |            | <ul style="list-style-type: none"> <li>Material Aluminium Alloy/Steel</li> <li>Finish Anodized /Clear Zinc Chromate</li> </ul>                   |
| 4                                       | 1 pc  | Lower Door Frame            |            | <ul style="list-style-type: none"> <li>Material Aluminium Alloy/Steel /Polyacetal (POM)</li> <li>Finish Anodized /Clear Zinc Chromate</li> </ul> |
| 5                                       | 1 pc  | Door End Cap (Upper Left)   |            | <ul style="list-style-type: none"> <li>Material ABS</li> <li>Colour Grey</li> </ul>  |
| 6                                       | 1 pc  | Door End Cap (Upper Right)  |            | <ul style="list-style-type: none"> <li>Material ABS</li> <li>Colour Grey</li> </ul>  |
| 7                                       | 1 pc  | Door End Cap (Lower Left)   |            | <ul style="list-style-type: none"> <li>Material ABS</li> <li>Colour Grey</li> </ul>  |
| 8                                       | 1 pc  | Door End Cap (Lower Right)  |            | <ul style="list-style-type: none"> <li>Material ABS</li> <li>Colour Grey</li> </ul>  |
| 9                                       | 4 pcs | Glass Fixing Holding Gasket |            | <ul style="list-style-type: none"> <li>Material Urethane Sponge</li> <li>Colour Black</li> </ul>   |

| No. | Qty             | Part Name                         | Dimensions | Description  |
|-----|-----------------|-----------------------------------|------------|--|
| 10  | 2 pcs           | Connecting Pin                    |            | <ul style="list-style-type: none"> <li>Material Stainless Steel</li> </ul> |
| 11  | 11 pcs (12 pcs) | Binding Head Tapping Screw 3.5x15 | -          | -  |

Qty: ( ) is for MFS-G600/S3, MFS-G600/S4, MFS-G600/S5, MFS-G900/S5, MFS-G900/S6 and MFS-G900/S7.

\*Made to order.

| End Cap Set (Per Door) |             | Necessary Parts<br>1 set is necessary for 1 unit. |  |
|------------------------|-------------|---|--|
| Set Name               | Item Code   | Item Name   |  |
| End Cap Set            | 250-129-555 | MFS-ED  |  |

Parts Included

| No. | Qty   | Part Name                             | Dimensions | Description   |
|-----|-------|---------------------------------------|------------|---|
| 12  | 1 pc  | End Cap L                             |            | <ul style="list-style-type: none"> <li>Material Steel</li> <li>Finish Grey</li> </ul> |
| 13  | 1 pc  | End Cap R                             |            | <ul style="list-style-type: none"> <li>Material Steel</li> <li>Finish Grey</li> </ul> |
| 14  | 1 pc  | Lower Rail Cover L                    |            | <ul style="list-style-type: none"> <li>Material ABS</li> <li>Finish Grey</li> </ul>   |
| 15  | 1 pc  | Lower Rail Cover R                    |            | <ul style="list-style-type: none"> <li>Material ABS</li> <li>Finish Grey</li> </ul>   |
| 16  | 4 pcs | Countersunk Head Tapping Screw 3.5x12 | -          | <ul style="list-style-type: none"> <li>Material Stainless Steel</li> </ul>            |

| Optional Parts |           | No.    |        | Item Code   | Part Name                           | Dimensions | Description   |
|----------------|-----------|--------|--------|-------------|-------------------------------------|------------|---|
| 17             | MFS-PK300 | 2 pcs. | 2 pcs. | 250-014-208 | Holding Gasket (Glass Width 295 mm) |            | When connecting glasses by double tape, please order one set per glass. Select (17) - (20) depend on glass width. |
|                |           |        |        |             | Gasket                              |            |   |
| 18             | MFS-PK450 | 2 pcs. | 2 pcs. | 250-014-209 | Holding Gasket (Glass Width 445 mm) |            | Gasket<br>Glass Protection Holding Gasket   |
|                |           |        |        |             | Gasket                              |            |   |
| 19             | MFS-PK600 | 2 pcs. | 2 pcs. | 250-014-210 | Holding Gasket (Glass Width 595 mm) |            | Gasket<br>Material Ethylene Propylene Rubber (EPDM)<br>Colour Grey  |
|                |           |        |        |             | Gasket                              |            |   |
| 20             | MFS-PK900 | 2 pcs. | 2 pcs. | 250-014-211 | Holding Gasket (Glass Width 895 mm) |            | Glass Protection Holding Gasket<br>Material Chloroprene Rubber (CR)<br>Colour Black                               |
|                |           |        |        |             | Gasket                              |            |   |

WARDROBE & CABINET DOOR HARDWARE

FOR GLASS DOORS

MULTIPLE MOTION DOOR SYSTEM

FLUSH SLIDING DOOR SYSTEM

MFU-1000

MonoFlat UNISON®

|                |                   |
|----------------|-------------------|
| Door Width     | 800 - 1000 mm     |
| Door Height    | Max. 2500 mm      |
| Door Thickness | *28 - 30 mm       |
| Door Weight    | Max. 30 kg        |
| Adjustability  | Depth: ±3.5 mm    |
|                | Horizontal: ±4 mm |
|                | Vertical: ±4 mm   |

\*Can be used on door thicker than 30 mm by mortising hanging bracket into the door.

Features

- Completely flush with surroundings, looks like it is just another part of the wall.
- Self-closing function pulls in door fully when it is close to closing.
- Easier installation due to reduced number of parts.
- Does not require a bottom rail. By using a bottom rail, door can be held more firmly.

WARDROBE & CABINET DOOR HARDWARE

FLUSH SLIDING DOOR SYSTEM



How the Door Moves

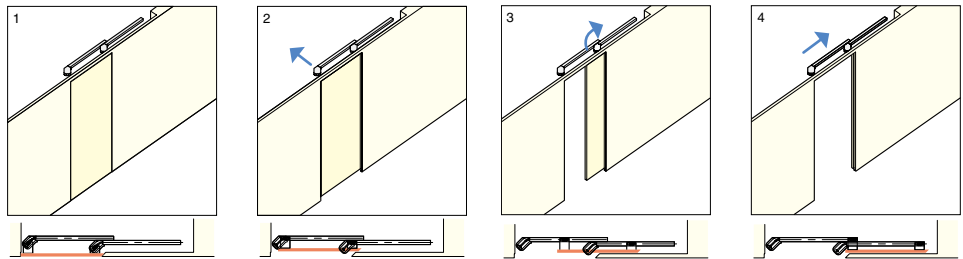

Installation

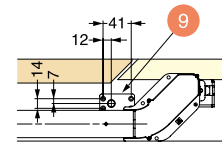
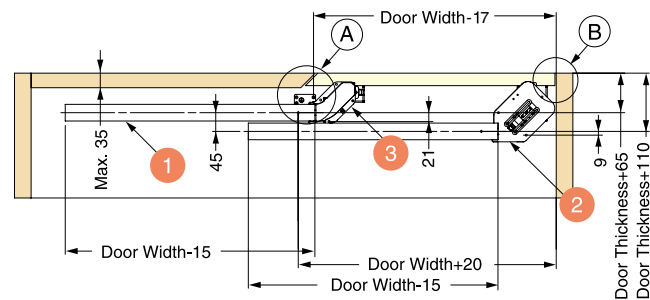
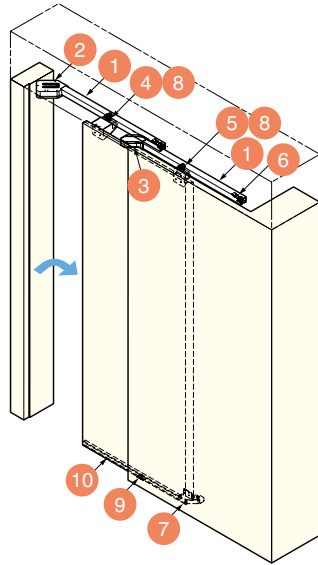

Detail (A)

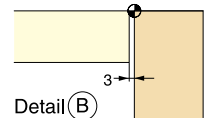

Detail (B)

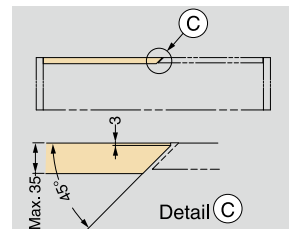

Detail (C)

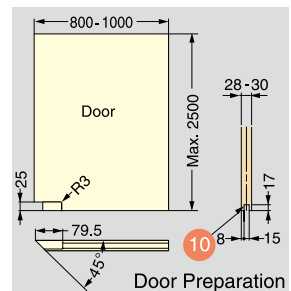
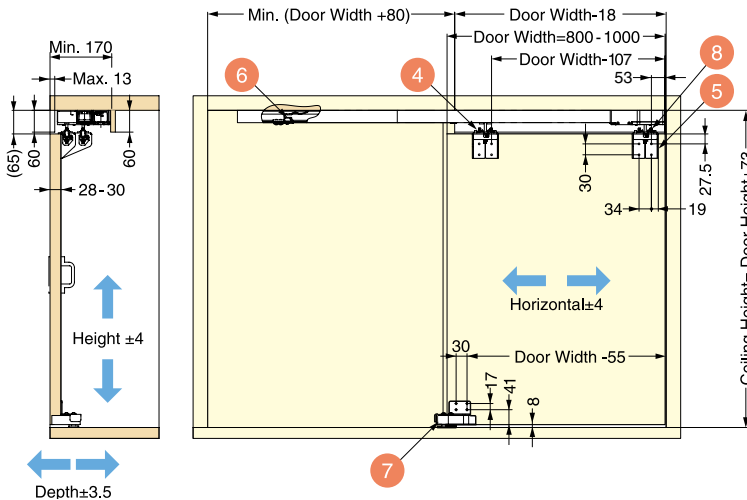

Door Preparation







LIN-X450, LIN-X600

MONOFLAT LIN-X HINGE

MonoFlat LIN-X hinge®



|                | LIN-X450        | LIN-X600        |
|----------------|-----------------|-----------------|
| Door Width     | 400 - 500 mm    | 550 - 650 mm    |
| Door Height    | 600 - 2400 mm   |                 |
| Door Thickness | 15 - 24 mm      |                 |
| Door Weight    | Max. 17 kg/Door | Max. 24 kg/Door |
| Overlay        | 19 mm           |                 |

Features

When opening or opened, cabinet doors will not get in the way. Unique and innovative design.

- Overlay installation that is flush with wall on both sides.
- Full access to cabinet interior: door will not get in the way when fully opened.
- Smooth operation: door is easy to move with little resistance no matter the position.
- Soft-closing: built-in damper makes door close gently, preventing slamming.
- Easy installation: Snap-in type installation. Same type of surface installation as concealed hinge mounting plate.
- Various applications including corner doors, double doors, overlapping doors.

WARDROBE & CABINET DOOR HARDWARE

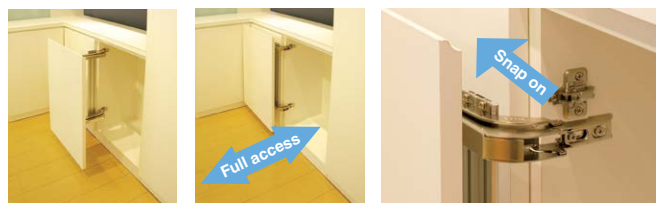

MONOFLAT LIN-X HINGE

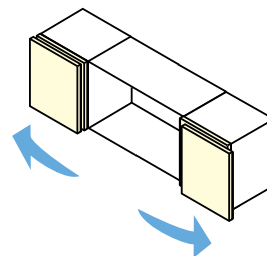
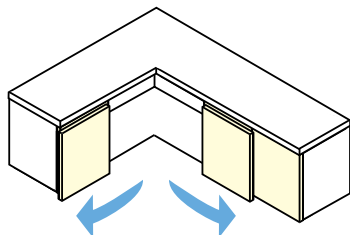
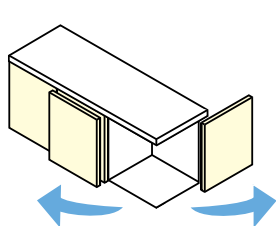
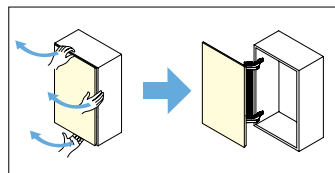
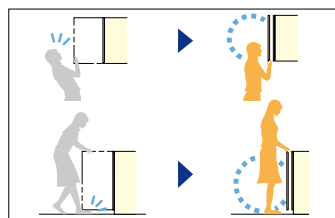

**LIN-X450 Standard Kit**

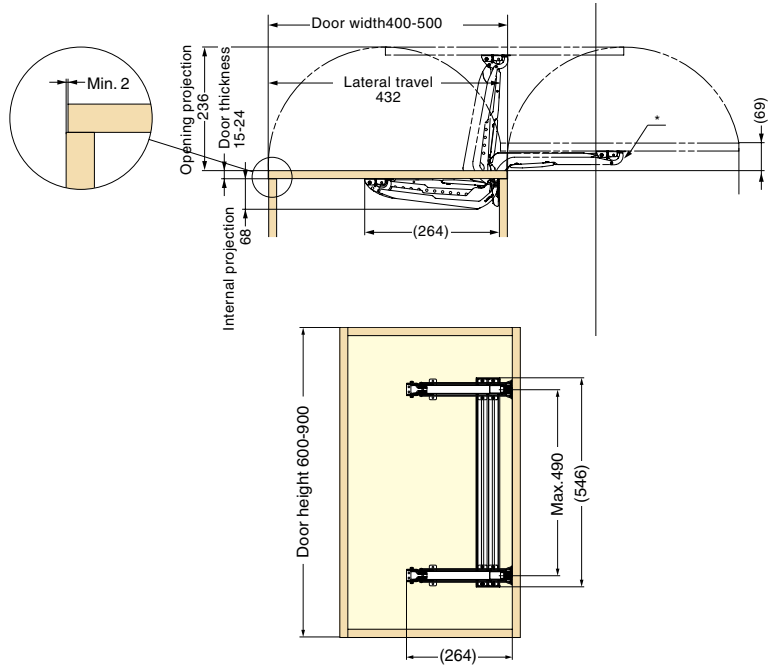
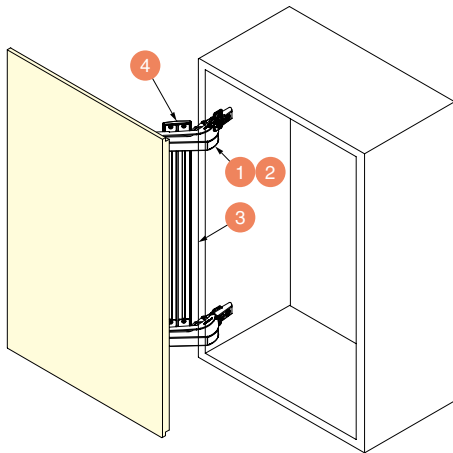

|                |                  |
|----------------|------------------|
| Door Width     | 400-500 mm       |
| Door Height    | 600-900 mm       |
| Door Thickness | 15-24 mm         |
| Door Weight    | Max. 7 kg / Door |

| Item Code   | Item Name  | Overlay | Mounting Plate | Material        | Finish          | Weight | Box   | Carton |
|-------------|------------|---------|----------------|-----------------|-----------------|--------|-------|--------|
| 250-014-240 | LIN-X450   | 19 mm   | 230-P4W-32T    | Steel/Aluminium | Nickel/Anodized | 2.2 kg | 1 set | 6 sets |
| 250-014-553 | LIN-X450+5 | 14 mm   | 230-P4W-32T+5  | Steel/Aluminium | Nickel/Anodized | 2.2 kg | 1 set | 6 sets |

**LIN-X600 Standard Kit**

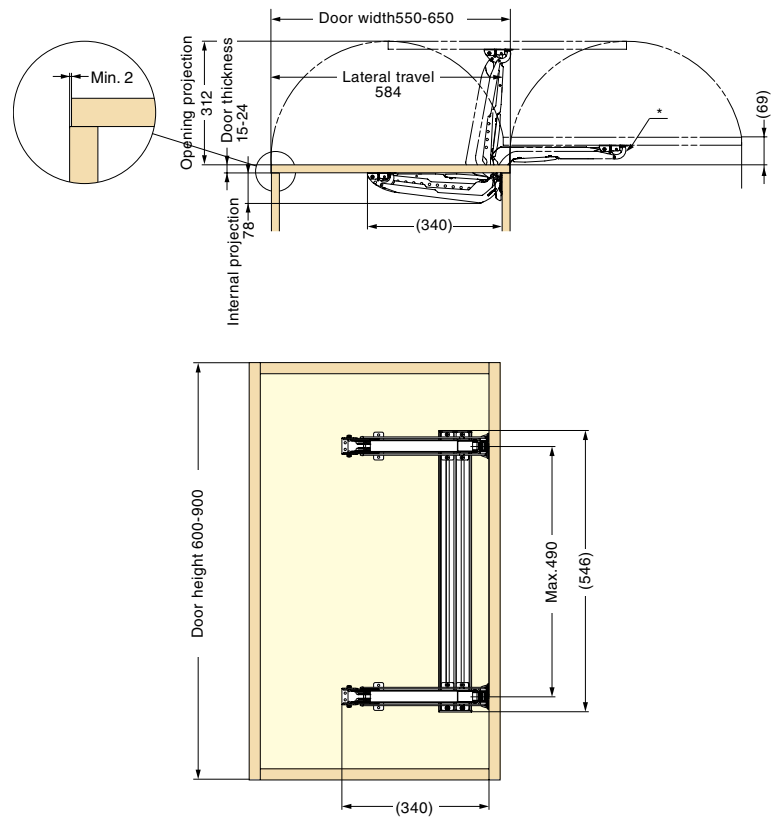
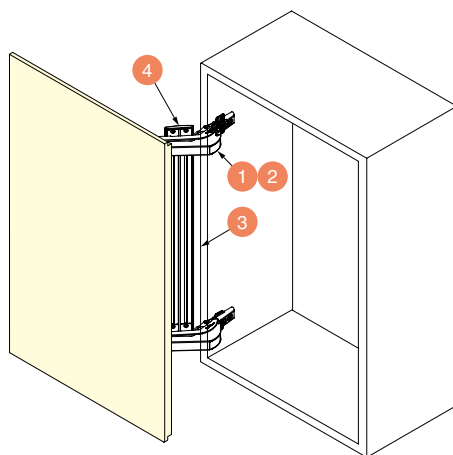

|                |                  |
|----------------|------------------|
| Door Width     | 550-650 mm       |
| Door Height    | 600-900 mm       |
| Door Thickness | 15-24 mm         |
| Door Weight    | Max. 9 kg / Door |

| Item Code   | Item Name | Overlay | Mounting Plate | Material        | Finish          | Weight | Box   | Carton |
|-------------|-----------|---------|----------------|-----------------|-----------------|--------|-------|--------|
| 250-017-590 | LIN-X600  | 19 mm   | 230-P4W-32T    | Steel/Aluminium | Nickel/Anodized | 3.2 kg | 1 set | 6 sets |

WARDROBE & CABINET DOOR HARDWARE

MONOFLAT LIN-X HINGE

## LIN-X450 Individual Parts for Tall/Heavy Door

Parts Set  
(Per Door)

## Necessary Parts

Please refer to parts included in each set.

| Item Code   | Item Name      | Door Height  | Door Weight | Parts Included  |  |  |   |
|-------------|----------------|--------------|-------------|---|--|--|---|
|             |                |              |             | Hinge Set<br>(With Damper)<br>Item Name : LIN-X450ACD | Hinge Set<br>(Without Damper)<br>Item Name : LIN-X450A | Connecting Bar<br>Item Name : LIN-X45-Lxxx | End Cap For<br>Connecting Bar<br>Item Name : LIN-X45C |
| 250-016-704 | LIN-X450S-1210 | 901-1200 mm  | 7.1-10.5 kg | 3 sets  | -  | 840 mm x 1 pc                              | 2 pcs   |
| 250-016-705 | LIN-X450S-1214 |              | 10.6-14 kg  | 3 sets  | 1 set  |  | 2 pcs   |
| 250-016-707 | LIN-X450S-1510 | 1201-1500 mm | 7.1-10.5 kg | 3 sets  | -  | 1140 mm x 1 pc                             | 2 pcs   |
| 250-016-708 | LIN-X450S-1514 |              | 10.6-14 kg  | 3 sets  | 1 set  |  | 2 pcs   |
| 250-016-709 | LIN-X450S-1517 |              | 14.1-17 kg  | 3 sets  | 2 sets   |  | 2 pcs   |
| 250-016-711 | LIN-X450S-1810 | 1501-1800 mm | 7.1-10.5 kg | 3 sets  | -  | 1440 mm x 1 pc                             | 2 pcs   |
| 250-016-712 | LIN-X450S-1814 |              | 10.6-14 kg  | 3 sets  | 1 set  |  | 2 pcs   |
| 250-016-713 | LIN-X450S-1817 |              | 14.1-17 kg  | 3 sets  | 2 sets   |  | 2 pcs   |
| 250-016-716 | LIN-X450S-2110 | 1801-2100 mm | 7.1-10.5 kg | 3 sets  | -  | 1740 mm x 1 pc                             | 2 pcs   |
| 250-016-717 | LIN-X450S-2114 |              | 10.6-14 kg  | 3 sets  | 1 set  |  | 2 pcs   |
| 250-016-718 | LIN-X450S-2117 |              | 14.1-17 kg  | 3 sets  | 2 sets   |  | 2 pcs   |
| 250-016-723 | LIN-X450S-2414 | 2101-2400 mm | 10.6-14 kg  | 3 sets  | 1 set  | 2040 mm x 1 pc                             | 2 pcs   |
| 250-016-724 | LIN-X450S-2417 |              | 14.1-17 kg  | 3 sets  | 2 sets   |  | 2 pcs   |



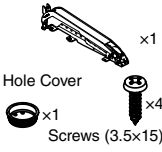
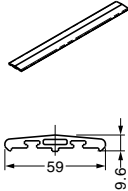
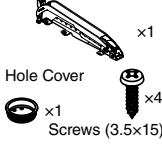
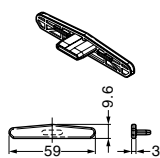

## Parts Included

| No. | Part Name                 | Description   | No. | Part Name                  | Description  |
|-----|---------------------------|---|-----|----------------------------|--|
| 1   | Hinge Body with Damper    |  <p>Item Code : 250-016-240<br/>Part Name : LIN-X450ACD</p> <ul style="list-style-type: none"> <li>Material: Steel</li> <li>Finish: Nickel</li> </ul> | 3   | Connecting Bar             |  <p>Item Code : 250-016-250<br/>Part Name : LIN-X45-L540</p> <p>Item Code : 250-016-252<br/>Part Name : LIN-X45-L840</p> <p>Item Code : 250-016-254<br/>Part Name : LIN-X45-L1140</p> <p>Item Code : 250-016-255<br/>Part Name : LIN-X45-L1440</p> <p>Item Code : 250-016-256<br/>Part Name : LIN-X45-L1740</p> <p>Item Code : 250-016-259<br/>Part Name : LIN-X45-L2040</p> <ul style="list-style-type: none"> <li>Material: Aluminium Alloy</li> <li>Finish: Anodized</li> </ul> |
| 2   | Hinge Body without Damper |  <p>Item Code : 250-016-242<br/>Part Name : LIN-X450A</p> <ul style="list-style-type: none"> <li>Material: Steel</li> <li>Finish: Nickel</li> </ul>  | 4   | End Cap for Connecting Bar |  <p>Item Code : 250-016-260<br/>Part Name : LIN-X45C</p> <ul style="list-style-type: none"> <li>Material: Polyacetal (POM)</li> <li>Color: Grey</li> </ul>   |

## Mounting Plate

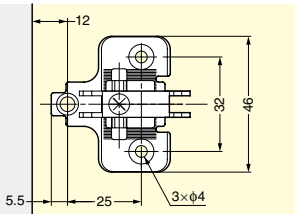
## Necessary Parts

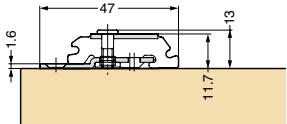
Same qty as hinge is necessary.

| Item Code   | Part Name   | Dimensions   | Description   |
|-------------|---|--|---|
| 160-070-041 | Mounting Plate  |   | <ul style="list-style-type: none"> <li>Material: Steel</li> <li>Finish: Nickel</li> </ul>   |
| 230-P4W-32T |  |  | <ul style="list-style-type: none"> <li>Material: Steel</li> <li>Finish: Nickel</li> </ul> <p>Same quantity with hinge is necessary.</p> |
| 160-070-030 | Raised Countersunk Head Tapping Screw 3.5x15  |   | <ul style="list-style-type: none"> <li>Material: Steel</li> <li>Finish: Nickel</li> </ul>   |
| TAP3515NI   |  | x3 per mounting plate  |   |

LIN-X600 Individual Parts for Tall/Heavy Door

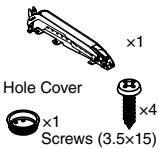
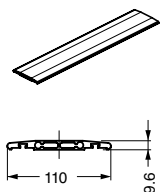
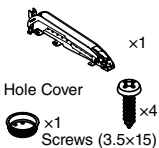
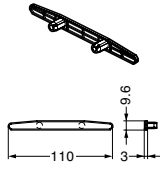

| Parts Set (Per Door) |                | Necessary Parts<br>Please refer to parts included in each set. |                 |  |   |  |  |
|----------------------|----------------|--|-----------------|--|---|--|--|
| Item Code            | Item Name      | Door Height  | Door Weight     | Parts Included                                     |   |  |  |
|                      |                |  |                 | Hinge Set (With Damper)<br>Item Name : LIN-X600ACD | Hinge Set (Without Damper)<br>Item Name : LIN-X600A | Connecting Bar<br>Item Name : LIN-X60-Lxxx | End Cap For Connecting Bar<br>Item Name : LIN-X60C |
| 250-017-068          | LIN-X600S-1212 | 901-1200 mm  | Less than 12 kg | 2 sets   | -   | 840 mm x 1 pc                              | 2 pcs  |
| 250-017-069          | LIN-X600S-1216 |  | 12.1-16 kg      | 3 sets   | -   |  | 2 pcs  |
| 250-017-071          | LIN-X600S-1516 | 1201-1500 mm   | Less than 16 kg | 3 sets   | -   | 1140 mm x 1 pc                             | 2 pcs  |
| 250-017-072          | LIN-X600S-1520 |  | 16.1-20 kg      | 3 sets   | 1 set   |  | 2 pcs  |
| 250-017-074          | LIN-X600S-1816 | 1501-1800 mm   | Less than 16 kg | 3 sets   | -   | 1440 mm x 1 pc                             | 2 pcs  |
| 250-017-075          | LIN-X600S-1820 |  | 16.1 kg-20 kg   | 3 sets   | 1 set   |  | 2 pcs  |
| 250-017-493          | LIN-X600S-1824 |  | 20.1-24 kg      | 3 sets   | 2 sets  |  | 2 pcs  |
| 250-017-077          | LIN-X600S-2116 | 1801-2100 mm   | Less than 16 kg | 3 sets   | -   | 1740 mm x 1 pc                             | 2 pcs  |
| 250-017-078          | LIN-X600S-2120 |  | 16.1 kg-20 kg   | 3 sets   | 1 set   |  | 2 pcs  |
| 250-017-079          | LIN-X600S-2124 |  | 20.1-24 kg      | 3 sets   | 2 sets  |  | 2 pcs  |
| 250-017-082          | LIN-X600S-2420 | 2101-2400 mm   | Less than 20 kg | 3 sets   | 1 set   | 2040 mm x 1 pc                             | 2 pcs  |
| 250-017-083          | LIN-X600S-2424 |  | 20.1-24 kg      | 3 sets   | 2 sets  |  | 2 pcs  |

Parts Included

| No. | Part Name  | Description   | No. | Part Name  | Description   |
|-----|--|---|-----|--|---|
| 1   | Hinge Body with Damper<br>     | Item Code : 250-016-962<br>Part Name : LIN-X600ACD<br>• Material Steel<br>• Finish Nickel | 3   | Connecting Bar<br>             | Item Code : 250-016-964<br>Part Name : LIN-X60-L540<br>Item Code : 250-016-965<br>Part Name : LIN-X60-L840<br>Item Code : 250-016-966<br>Part Name : LIN-X60-L1140<br>Item Code : 250-016-967<br>Part Name : LIN-X60-L1440<br>Item Code : 250-016-968<br>Part Name : LIN-X60-L1740<br>Item Code : 250-016-969<br>Part Name : LIN-X60-L2040<br>• Material Aluminium Alloy<br>• Finish Anodized |
| 2   | Hinge Body without Damper<br> | Item Code : 250-016-963<br>Part Name : LIN-X600A<br>• Material Steel<br>• Finish Nickel   | 4   | End Cap for Connecting Bar<br> | Item Code : 250-016-970<br>Part Name : LIN-X60C<br>• Material Polyacetal (POM)<br>• Colour Grey   |

WARDROBE & CABINET DOOR HARDWARE

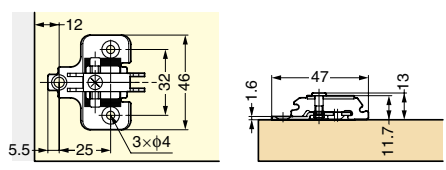
MONOFLAT LIN-X HINGE

| Mounting Plate |   | Necessary Parts<br>Same qty as hinge is necessary.                                   |  |
|----------------|---|--|--|
| Item Code      | Part Name   | Dimensions   | Description  |
| 160-070-041    | Mounting Plate<br>                               |  | • Material Steel<br>• Finish Nickel<br>*Same quantity with hinge is necessary. |
| 160-070-030    | Raised Countersunk Head Tapping Screw 3.5x15<br> | x3 per mounting plate  | • Material Steel<br>• Finish Nickel  |

Hinge Installation Pitch and Other Dimensions

LIN-X450

Door Preparation

Cabinet Preparation

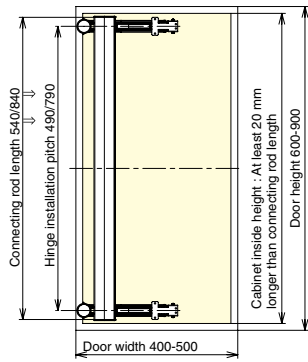
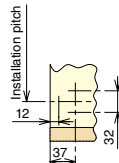
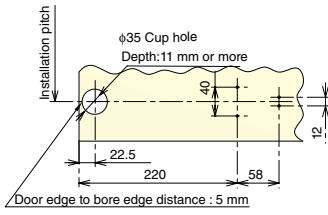

Door thickness 15-24  
Door weight up to 7 kg  
2 Hinges per door  
(① LIN-X450ACD : 2 pcs)

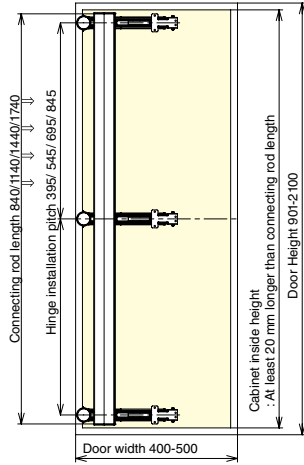

Door thickness 15-24  
Door weight up to 10.5 kg  
3 Hinges per door  
(① LIN-X450ACD : 3 pcs)

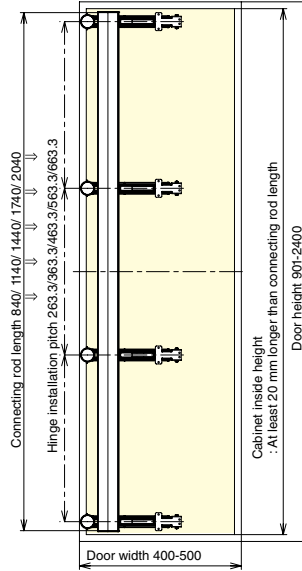

Door thickness 15-24  
Door weight up to 14 kg  
4 Hinges per door  
(① LIN-X450ACD : 3 pcs)  
(② LIN-X450A : 1 pc)  
\*Please install the ② to the second place from the bottom.

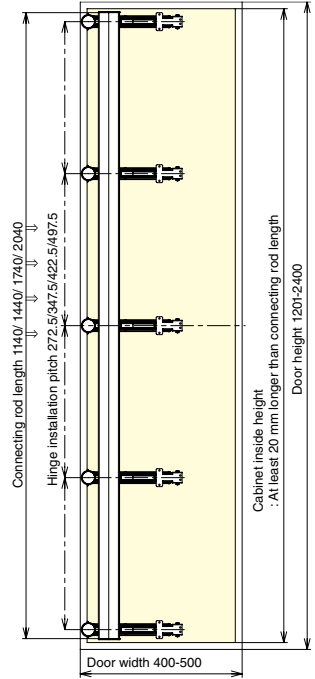

Door thickness 15-24  
Door weight up to 17 kg  
5 Hinges per door  
(① LIN-X450ACD : 3 pcs)  
(② LIN-X450A : 2 pcs)  
\*Please install the ② to the 2nd and 3rd place from the bottom.

WARDROBE & CABINET DOOR HARDWARE

Hinge Installation Pitch and Other Dimensions

LIN-X600

Door Preparation

Cabinet Preparation

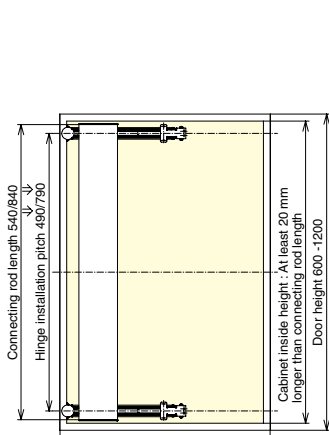
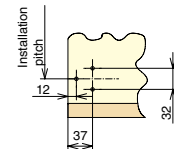
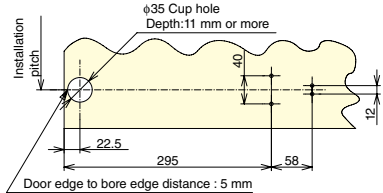

Door thickness 15-24  
Door weight  
Door height 600-1200  
⇒ Door weight up to 9 kg  
Door height 901-1200  
⇒ Door weight up to 12 kg  
2 Hinges per door  
(① LIN-X600 ACD : 2 pcs)

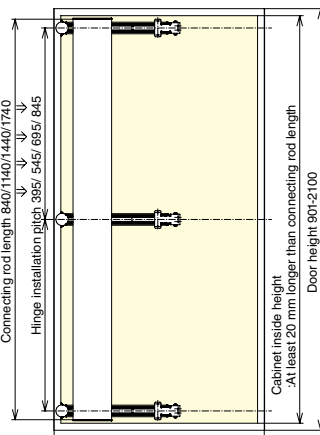

Door thickness 15-24  
Door weight  
Door height 901-2100  
⇒ Door weight up to 16 kg  
3 Hinges per door  
(① LIN-X600 ACD : 3 pcs)

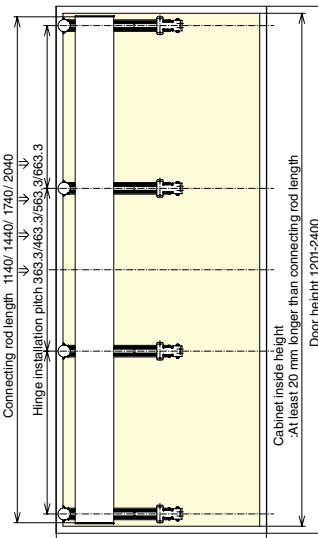

Door thickness 15-24  
Door weight up to 20 kg  
4 Hinges per door  
(① LIN-X600 ACD : 3 pcs)  
(② LIN-X600 A : 1 pc)  
\*Please install the ② to the 2nd place from the bottom.

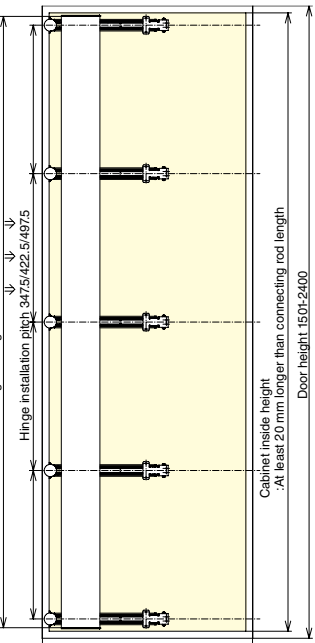

Door thickness 15-24  
Door weight up to 24 kg  
5 Hinges per door  
(① LIN-X600 ACD : 3 pcs)  
(② LIN-X600 A : 2 pcs)  
\* Please install the ② to the 2nd and 3rd place from the bottom.

MONOFLAT LIN-X HINGE



MONOFLAT LIN-X HINGE (HEAVY DUTY)



LIN-X1000



MonoFlat LIN-X hinge®

|                | LIN-X1000       |
|----------------|-----------------|
| Door Width     | 750 - 1100 mm   |
| Door Height    | Max. 2980 mm    |
| Door Thickness | 24 - 40 mm      |
| Door Weight    | Max. 90 kg/Door |

Features

- Unique lateral swinging movement.
- Swings out in small radius. Closes flush.
- Full access to cabinet interior: door will not get in the way when fully opened.
- Easier installation due to simplification of components.
- Free-stop: holds position at desired location within its open radius.
- Soft-closing: built-in damper slows down door near closing radius, preventing slamming.
- 4way post-installation adjustment: vertical ( $\pm 7$  mm), horizontal ( $\pm 7$  mm), depth ( $\pm 5$  mm) and parallel ( $\pm 3^\circ$ ).
- Good Design Show winner 2016
- Reddot Product Design winner 2017
- Passed 100,000 open/close cycles in a private test.

Parts Included

Truss head tapping screw 6x25 (16 pieces)

Applicable Door Load Capacity

| Open/Close cycles | Door sagging |       |
|-------------------|--------------|-------|
|                   | 3 mm         | 5 mm  |
| 60,000            | 70 kg        | 90 kg |
| 80,000            | 50 kg        | 80 kg |
| 100,000           | 40 kg        | 70 kg |

Colour variation

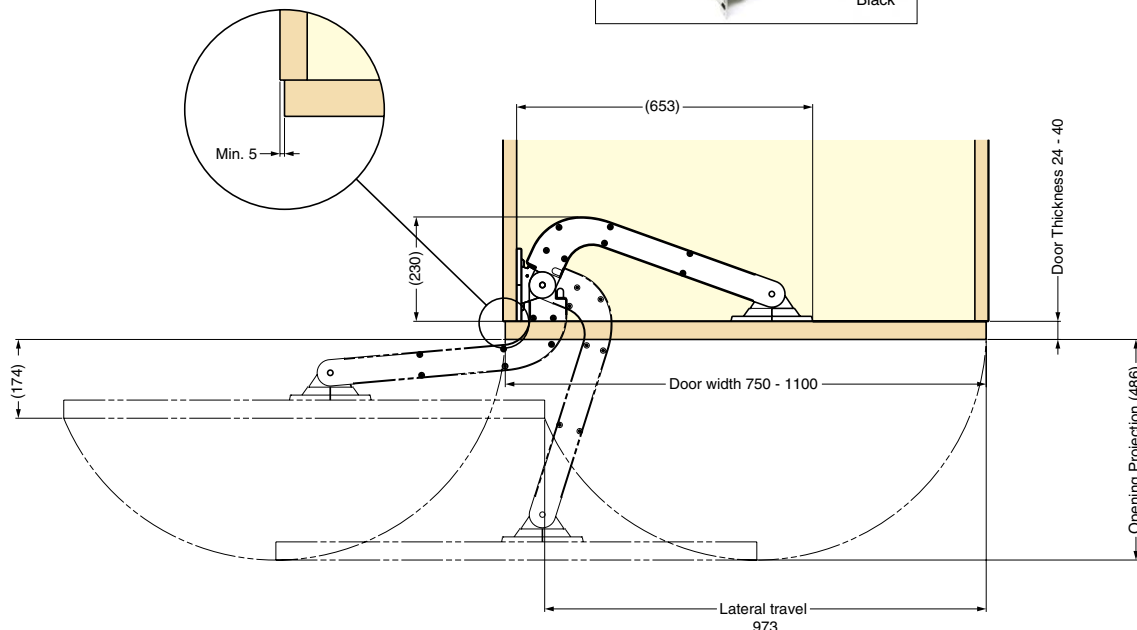
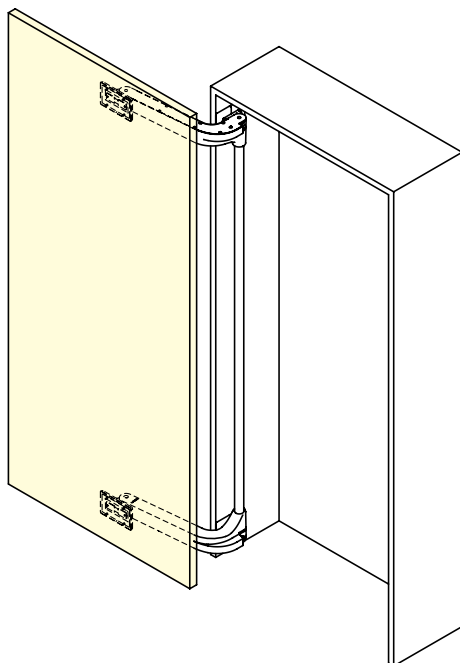

**Parts Set (Per Door)** Necessary Parts

| Item Code   | Item Name     |
|-------------|---------------|
| 250-034-706 | *LIN-X1000-WT |
| 250-042-288 | LIN-X1000-BL  |

Parts Included

\*The item name has been changed.

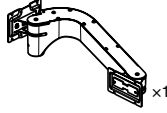
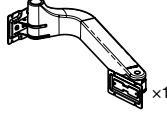
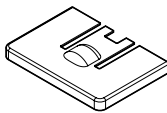
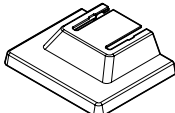
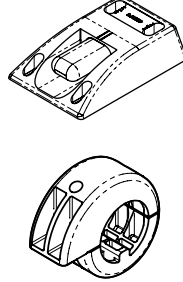
| No. | Qty   | Part Name   | Description  |
|-----|-------|---|--|
| 1   | 1 pc  | <br>Arm A                                  | <ul style="list-style-type: none"> <li>Material Aluminium Alloy</li> <li>Finish Powder Coating/ White/Black</li> </ul> |
| 2   | 1 pc  | <br>Arm B                                  | <ul style="list-style-type: none"> <li>Material Aluminium Alloy</li> <li>Finish Powder Coating/ White/Black</li> </ul> |
| 3   | 4 pcs | <br>Cover for Mounting Plate (Hinge Side) | <ul style="list-style-type: none"> <li>Material ABS Resin</li> <li>Finish White/Black</li> </ul>                       |
| 4   | 4 pcs | <br>Cover for Mounting Plate (Door Side) | <ul style="list-style-type: none"> <li>Material ABS Resin</li> <li>Finish White/Black</li> </ul>                       |
| 5   | 1 pc  | <br>Damper for Opening                   | <ul style="list-style-type: none"> <li>Material PBT Resin</li> <li>Finish White/Black</li> </ul>                       |

Parts Drawing

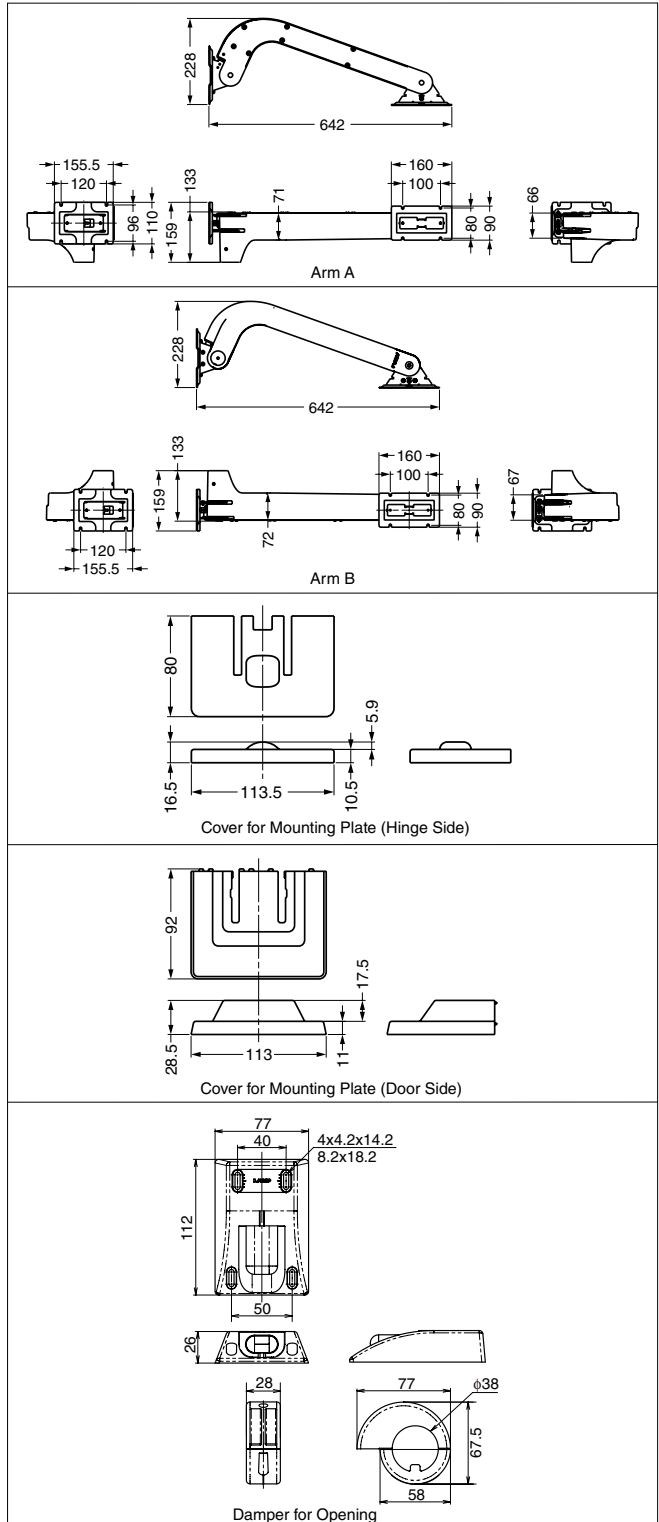

**Connecting Bar** Necessary Parts

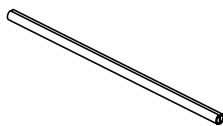
| No. | Qty  | Part Name   | Item Code   | Item Name          | Description   |
|-----|------|---|-------------|--------------------|---|
| 5   | 1 pc | <br>Connecting Bar | 250-034-707 | *LIN-X100-L2000-WT | <ul style="list-style-type: none"> <li>Material Aluminium Extrusion</li> <li>Finish White Anodized</li> </ul> |
|     |      |   | 250-042-289 | LIN-X100-L2000-BL  | <ul style="list-style-type: none"> <li>Material Aluminium Extrusion</li> <li>Finish Black Anodized</li> </ul> |

\*The item name has been changed.

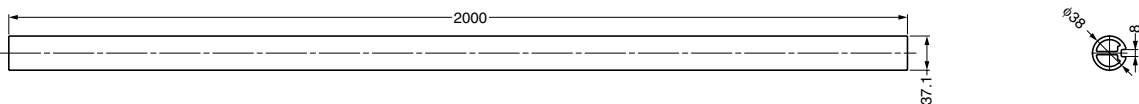

Various Applications

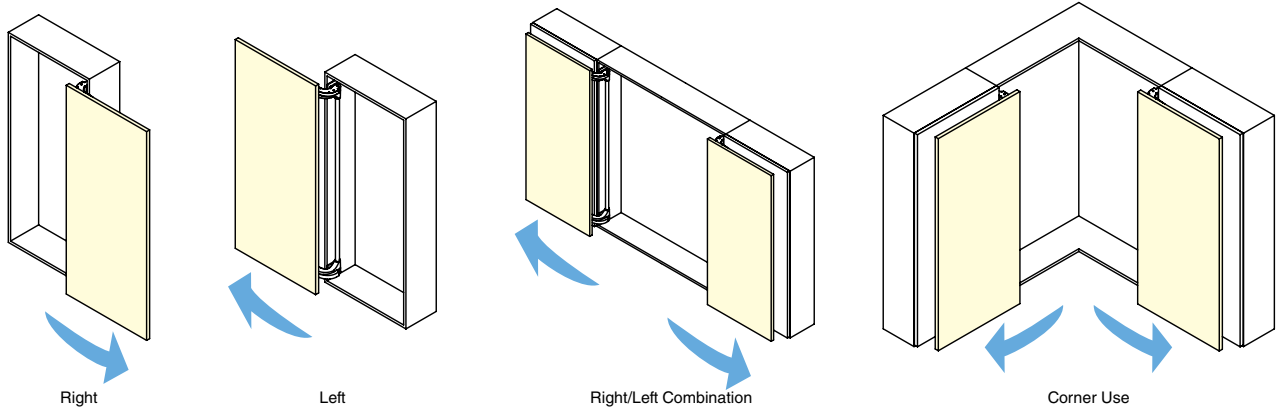

Door arc

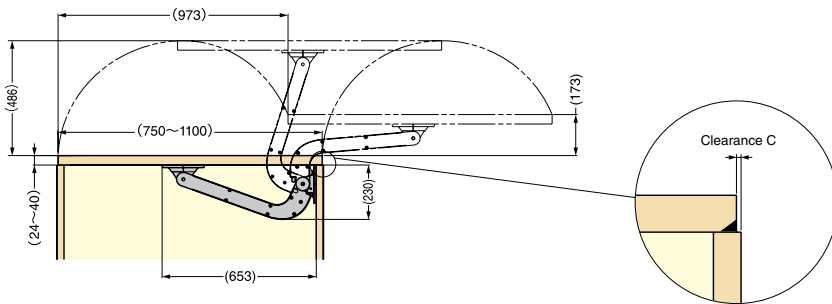

\*Please adjust Clearance C depending on the handle position.  
For detail, refer to a manual.

Installation

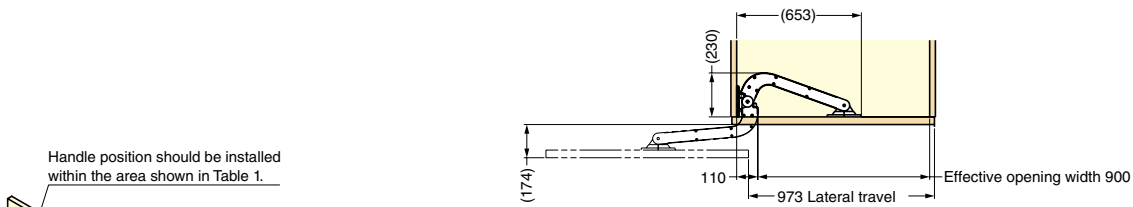

Handle position should be installed within the area shown in Table 1.

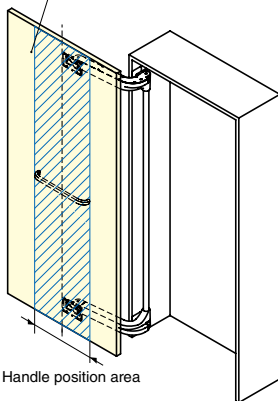
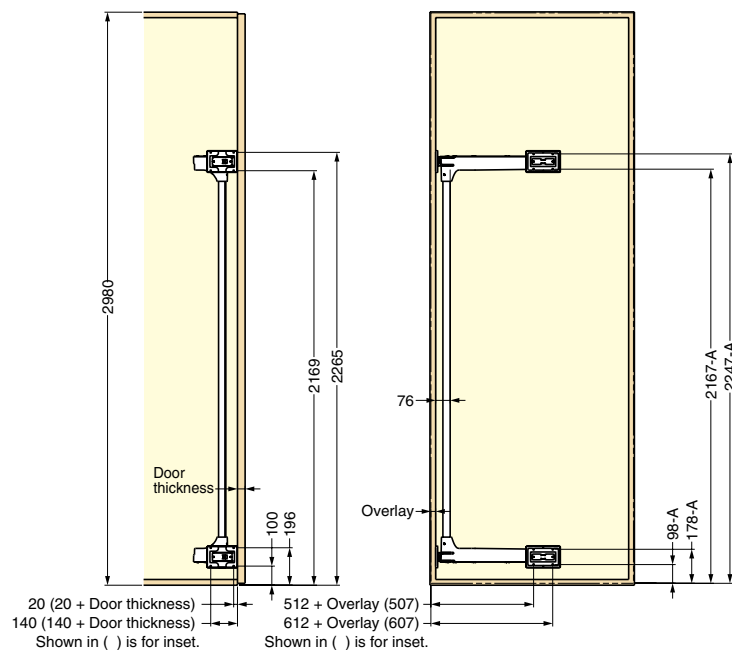

Table 1 : Handle position area [mm]

| Door width | Clearance C |         |         |
|------------|-------------|---------|---------|
|            | 10          | 15      | 20      |
| 750-900    | Max.300     | Max.350 | Max.500 |
| 900-1000   | Max.200     | Max.250 | Max.400 |
| 1000-1100  | Max.100     | Max.150 | Max.300 |

\*Door thickness : 40mm  
\*Handle position area is centered on the door width.



The table below shows the adjustment factor A depending on the door weight. Ensure that you adjust according to your door weight.

| Door weight | Adjustment factor A |
|-------------|---------------------|
| 20kg        | 2mm                 |
| 30kg        | 3.5mm               |
| 40kg        | 5mm                 |
| 50kg        | 6.5mm               |
| 60kg        | 8mm                 |
| 70kg        | 9.5mm               |
| 80kg        | 11mm                |
| 90kg        | 12.5mm              |

\*If you use a thick carpet, ensure that there is enough clearance for free movement of the door.  
\*A ± 7mm height adjustment is possible after installation. For detail, please refer to a manual.

MONOFLAT FAD (FOR SMALL SIZE CABINET)

FAD-5



MonoFlat FAD®

|                |                |
|----------------|----------------|
| Door Width     | 270-350 mm     |
| Door Height    | 260-650 mm     |
| Door Thickness | 15-20 mm       |
| Door Weight    | Max. 5 kg/Door |

Features

- Lateral swinging system for smaller cabinets with an overlay installation.
- Smaller opening radius than swing open doors. Does not get in the way after being opened.
- Doors close gently and quietly.
- 3way adjustment post-installation: vertical(±3mm), horizontal(±2.5mm), parallel (5°).
- Great solution for kitchen, bathroom and laundry room cabinets.
- Various types of installations: Can be used on single or double doors.

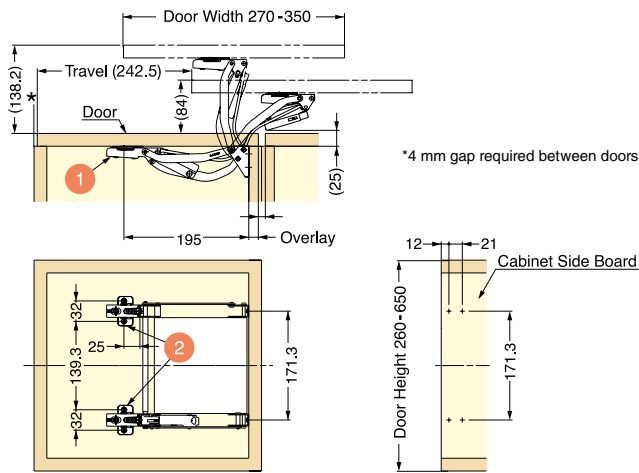
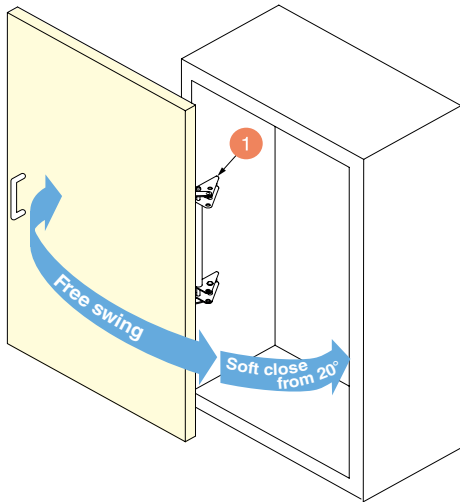

Hinge Dimensions

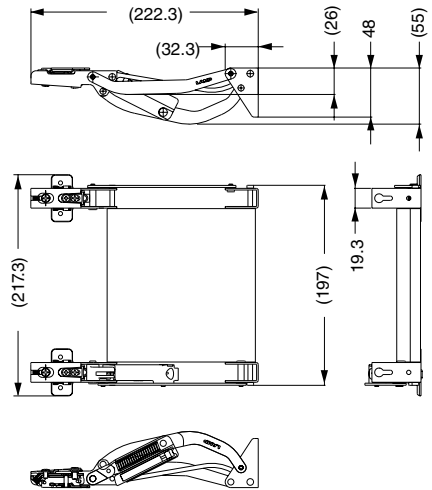

Parts Set (Per Door)

Necessary Parts

| Item Code   | Item Name |
|-------------|-----------|
| 250-016-605 | FAD-5     |

Parts Included

| No. | Qty  | Part Name  | Drawing | Description | No. | Qty   | Part Name      | Drawing | Description   |
|-----|------|------------|---------|-------------|-----|-------|----------------|---------|---|
| 1   | 1 pc | Hinge Body |         | As above.   | 2   | 2 pcs | Mounting Plate |         | Item Code : 160-070-041<br>Part Name : 230-P4W-32T<br>• Material Steel<br>• Finish Nickel |

WARDROBE & CABINET DOOR HARDWARE

MONOFLAT FAD (FOR SMALL SIZE CABINET)

MONOFLAT FAD (FOR MEDIUM SIZE CABINET)

FAD-20



MonoFlat FAD®

|                       |                 |
|-----------------------|-----------------|
| Inside Cabinet Width  | 500 - 550 mm    |
| Inside Cabinet Height | Max. 2420 mm    |
| Door Thickness        | Max. 35 mm      |
| Door Weight           | Max. 20 kg/Door |

Features

- Lateral swing system for medium-sized cabinets with an overlay installation.
- Smaller opening radius than swing open doors. Does not get in the way after being opened.
- Uses a gas spring to make opening and closing smooth with little resistance.
- Holds door firmly in fully opened and fully closed positions.
- Various types of installations: Can be used on single or double doors.

WARDROBE & CABINET DOOR HARDWARE

MONOFLAT FAD (FOR MEDIUM SIZE CABINET)

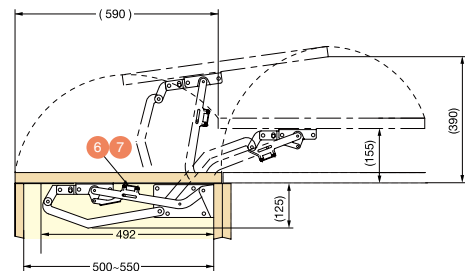
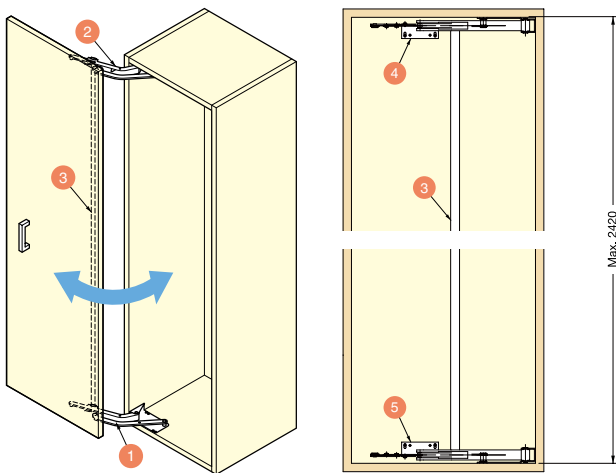

Parts Set (Per Door) Necessary Parts

| Item Code   | Item Name |
|-------------|-----------|
| 250-180-908 | FAD-20    |

Parts Details

| No. | Qty   | Part Name       | Dimensions | Description   |
|-----|-------|-----------------|------------|---|
| 1   | 1 pc  | Arm A           |            | <ul style="list-style-type: none"> <li>• Material Aluminium Alloy/Steel</li> <li>• Finish Matte Silver</li> </ul> |
| 2   | 1 pc  | Arm B           |            | <ul style="list-style-type: none"> <li>• Material Aluminium Alloy/Steel</li> <li>• Finish Matte Silver</li> </ul> |
| 3   | 1 pc  | Connecting Pipe |            | <ul style="list-style-type: none"> <li>• Material Steel</li> <li>• Finish Matte Silver</li> </ul>                 |
| 4   | 1 pc  | Upper Bracket   |            | <ul style="list-style-type: none"> <li>• Material Steel</li> <li>• Finish Matte Silver</li> </ul>                 |
| 5   | 1 pc  | Lower Bracket   |            | <ul style="list-style-type: none"> <li>• Material Steel</li> <li>• Finish Matte Silver</li> </ul>                 |
| 6   | 2 pcs | Pipe Clamp      |            | <ul style="list-style-type: none"> <li>• Material Steel</li> <li>• Finish Matte Silver</li> </ul>                 |
| 7   | 2 pcs | Cap             |            | <ul style="list-style-type: none"> <li>• Material Polyethylene (PE)</li> <li>• Colour Black</li> </ul>            |
| 8   | 1 pc  | Sticker         | -          | -   |

MONOFLAT FAD (FOR LARGE SIZE CABINET)



FAD-44



MonoFlat FAD®

|                | FAD-44          | FAD-44L      |
|----------------|-----------------|--------------|
| Door Width     | 800 - 850 mm*1  |              |
| Door Height    | Max. 2380 mm    | Max. 2980 mm |
| Door Thickness | 24 - 38 mm      |              |
| Door Weight    | Max. 35 kg/Door |              |

\*1 Cabinet inner width 750 - 800 mm and overlay 25 mm.

Features

- Lateral swing system for full-sized cabinets with an overlay installation.
- Doors close flush with neighboring walls or doors for a clean and sleek appearance.
- Smaller opening radius than swing open doors. Does not get in the way after being opened.
- No need to do any processing on the bottom of the cabinet.
- Height can be adjusted by cutting the arm connector.
- Uses a gas spring to make opening and closing smooth with little resistance.
- Holds door firmly in fully opened and fully closed positions.
- Can be adjusted vertically (-3+7 mm) and horizontally (+/- 7 mm) post installation.
- For wooden frames. FAD-54 is a similar product for aluminium frames.

WARDROBE & CABINET DOOR HARDWARE

MONOFLAT FAD (FOR LARGE SIZE CABINET)

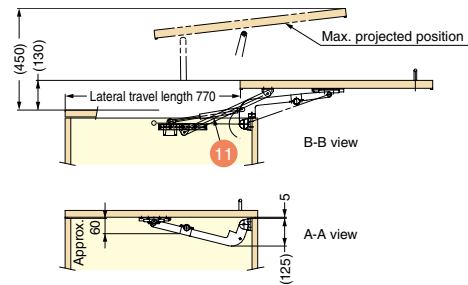
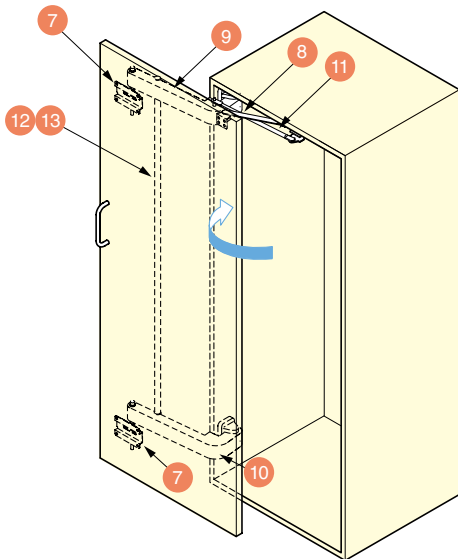

Opening Variations (Single / Double Doors)

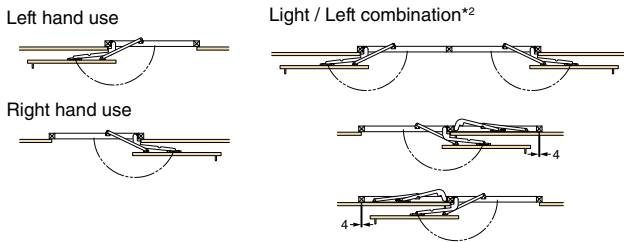

\*2 Vertical frame or door stoppers on floor for both doors required in center.

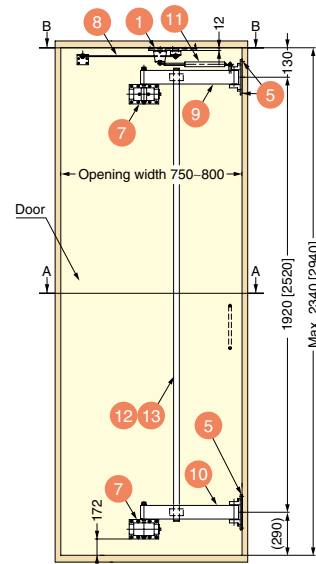

Dimension in [ ] shows FAD-44L.

| Parts Set (Per Door)                             |             | Necessary Parts   |  |
|--|-------------|---|--|
|  |             | Please choose <b>a</b> or <b>b</b> depending on your door height. |  |
| Set Name   | Item Code   | Item Name   |  |
| <b>a</b> Parts Set<br>(Max. Door Height 2380 mm) | 250-121-312 | FAD-44  |  |
| <b>b</b> Parts Set<br>(Max. Door Height 2980 mm) | 250-021-950 | FAD-44L   |  |

Parts Details

| No. | Qty   |       | Part Name                                       | Dimensions | Description  |
|-----|-------|-------|---|------------|--|
|     | a     | b     |   |            |  |
| 1   | 1 pc  | 1 pc  | Gas Spring Bracket                              |            | <ul style="list-style-type: none"> <li>Material Steel</li> <li>Finish Clear Zinc Chromate</li> </ul>             |
| 2   | 1 pc  | 1 pc  | Screw Pin                                       |            | <ul style="list-style-type: none"> <li>Material Steel</li> <li>Finish Clear Zinc Chromate</li> </ul>             |
| 3   | 1 pc  | 1 pc  | Channel Rail                                    |            | <ul style="list-style-type: none"> <li>Material Steel</li> <li>Finish Nickel</li> </ul>                          |
| 4   | 1 pc  | 1 pc  | Support Arm Square Nut<br>Gas Spring Square Nut |            | <ul style="list-style-type: none"> <li>Material Steel</li> <li>Finish Clear Zinc Chromate</li> </ul>             |
| 5   | 4 pcs | 4 pcs | Bearing Housing                                 |            | <ul style="list-style-type: none"> <li>Material Aluminium Alloy</li> <li>Finish/Colour Silver</li> </ul>         |
| 6   | 2 pcs | 2 pcs | Hinge Base Plate                                |            | <ul style="list-style-type: none"> <li>Material Zinc Alloy (ZDC)</li> <li>Finish/Colour Silver</li> </ul>        |
| 7   | 2 pcs | 2 pcs | Adjustment Bracket                              |            | <ul style="list-style-type: none"> <li>Material Steel, Polyacetal (POM)</li> <li>Colour Silver</li> </ul>        |
| 8   | 1 pc  | 1 pc  | Support Arm                                     |            | <ul style="list-style-type: none"> <li>Material Steel, Polyacetal (POM)</li> <li>Finish/Colour Silver</li> </ul> |
| 9   | 1 pc  | 1 pc  | Upper Arm                                       |            | <ul style="list-style-type: none"> <li>Material Aluminium Alloy</li> <li>Finish/Colour Silver</li> </ul>         |

| No. | Qty  |      | Part Name  | Dimensions | Description   |
|-----|------|------|--|------------|---|
|     | a    | b    |  |            |   |
| 10  | 1 pc | 1 pc | Lower Arm  |            | <ul style="list-style-type: none"> <li>Material Aluminium Alloy</li> <li>Finish/Colour Silver</li> </ul>  |
| 11  | 1 pc | 1 pc | Gas Spring   |            | <ul style="list-style-type: none"> <li>Colour Grey</li> </ul>   |
| 12  | 1 pc | -    | Arm Connecting & Clamp (Pipe Length 1990 mm for FAD-44)  |            | <ul style="list-style-type: none"> <li>Material Steel</li> <li>Finish/Colour Silver</li> </ul>  |
| 13  | -    | 1 pc | Arm Connecting & Clamp (Pipe Length 2600 mm for FAD-44L) |            | <ul style="list-style-type: none"> <li>Material Steel</li> <li>Finish/Colour Silver</li> </ul>  |
| 14  | 1 pc | 1 pc | Clear Bumper   |            | <p>Item Code : 210-030-639</p> <p>Part Name : BS-36</p> <ul style="list-style-type: none"> <li>Material Polyurethane (PUR)</li> <li>Finish Clear</li> </ul> |
| 15  | 1 pc | 1 pc | Strip Brush  |            | <ul style="list-style-type: none"> <li>Colour Grey</li> </ul>   |

WARDROBE & CABINET DOOR HARDWARE

MONOFLAT FAD (FOR LARGE SIZE CABINET)





| Parts Set (Per Door)                   |             | Necessary Parts   |  |
|--|-------------|---|--|
|  |             | Please refer to "Qty [a] - [b]" for parts included in each set. |  |
| Set Name                               | Item Code   | Item Name   |  |
| a Parts Set (Max. Door Height 2380 mm) | 250-121-314 | FAD-54  |  |
| b Parts Set (Max. Door Height 2980 mm) | 250-021-876 | FAD-54L   |  |

Parts Included

| No. | Qty   |       | Part Name   | Dimensions | Description   |
|-----|-------|-------|---|------------|---|
|     | a     | b     |   |            |   |
| 1   | 1 pc  | 1 pc  | Gas Spring Bracket  |            | <ul style="list-style-type: none"> <li>Material Steel</li> <li>Finish Clear Zinc Chromate</li> </ul>                |
| 2   | 1 pc  | 1 pc  | Screw Pin   |            | <ul style="list-style-type: none"> <li>Material Steel</li> <li>Finish Clear Zinc Chromate</li> </ul>                |
| 3   | 4 pcs | 4 pcs | Bearing Housing   |            | <ul style="list-style-type: none"> <li>Material Aluminium Alloy</li> <li>Finish / Colour Silver</li> </ul>          |
| 4   | 2 pcs | 2 pcs | Adjustment Bracket  |            | <ul style="list-style-type: none"> <li>Material Steel / Polyacetal (POM)</li> <li>Colour Silver</li> </ul>          |
| 5   | 1 pc  | 1 pc  | Support Arm   |            | <ul style="list-style-type: none"> <li>Material Steel / Polyacetal (POM)</li> <li>Finish / Colour Silver</li> </ul> |
| 6   | 1 pc  | 1 pc  | Upper Arm   |            | <ul style="list-style-type: none"> <li>Material Aluminium Alloy</li> <li>Finish / Colour Silver</li> </ul>          |
| 7   | 1 pc  | 1 pc  | Lower Arm   |            | <ul style="list-style-type: none"> <li>Material Aluminium Alloy</li> <li>Finish / Colour Silver</li> </ul>          |
| 8   | 1 pc  | 1 pc  | Gas Spring  |            | <ul style="list-style-type: none"> <li>Colour Grey</li> </ul>   |
| 9   | 1 set | -     | Arm Connector & Clamp (For FAD-54/ Pipe Length 1990 mm)   |            | <ul style="list-style-type: none"> <li>Material Steel</li> <li>Finish / Colour Silver</li> </ul>                    |
| 10  | -     | 1 set | Arm Connector & Clamp (For FAD-54L / Pipe Length 2600 mm) |            | <ul style="list-style-type: none"> <li>Material Steel</li> <li>Finish / Colour Silver</li> </ul>                    |

| No. | Qty   |       | Part Name                  | Dimensions | Description   |
|-----|-------|-------|----------------------------|------------|---|
|     | a     | b     |                            |            |   |
| 11  | 1 pc  | 1 pc  | Clear Bumper               |            | <p>Item Code : 210-030-639<br/>Item Name : BS-36</p> <ul style="list-style-type: none"> <li>Material Polyurethane (PUR)</li> <li>Finish Clear</li> </ul>  |
| 12  | 1 pc  | 1 pc  | Strip Brush                | -          | <ul style="list-style-type: none"> <li>Colour Grey</li> </ul>   |
| 13  | 2 pcs | -     | Aluminum Frame for FAD-54  |            | <ul style="list-style-type: none"> <li>Material Aluminium Alloy</li> <li>Finish Anodized+Clear</li> </ul> <p>*Vertical: 2300 mmx2 pcs<br/>Horizontal: 800 mmx1 pc</p>                             |
| 14  | -     | 1 pc  | Aluminum Frame for FAD-54L |            | <ul style="list-style-type: none"> <li>Material Aluminium Alloy</li> <li>Finish Anodized+Clear</li> </ul> <p>*Vertical: 2900 mmx2 pcs<br/>Horizontal: 800 mmx1 pc</p>                             |
| 15  | 4 pcs | 4 pcs | Leveling Glide Base        |            | <ul style="list-style-type: none"> <li>Material Steel</li> <li>Finish / Colour Silver</li> </ul>  |
| 16  | 4 pcs | 4 pcs | Bracket for Aluminum Frame |            | <ul style="list-style-type: none"> <li>Material Aluminium Alloy</li> <li>Finish / Colour Silver</li> </ul>  |
| 17  | 6 pcs | 6 pcs | Angle Connector            |            | <ul style="list-style-type: none"> <li>Material Steel</li> <li>Finish Clear Zinc Chromate</li> </ul>  |
| 18  | 4 pcs | 4 pcs | Leveling Glide             |            | <p>Item Code : 200-140-593<br/>Item Name : ADR37-10-50</p> <ul style="list-style-type: none"> <li>Material Steel / Elastomer (TPE)</li> <li>Finish Clear Zinc Chromate / Black</li> </ul>         |
| 19  | 8 pcs | 8 pcs | Corner Connector           |            | <p>Item Code : 120-040-456<br/>Item Name : P-J-60</p> <ul style="list-style-type: none"> <li>Material Aluminium Alloy / Zinc Alloy (ZDC)</li> <li>Finish Silver / Yellow Zinc Chromate</li> </ul> |

OVER TRAVEL SLIDING DOOR SYSTEM

OX



|                |                |
|----------------|----------------|
| Door Width     | 305 - 328 mm   |
| Door Height    | Max. 900 mm    |
| Door Thickness | 20 mm          |
| Door Weight    | Max. 5 kg/Door |

Features

- Over travel rail allows full access to cabinet inside.
- Suitable for limited space.

WARDROBE & CABINET DOOR HARDWARE

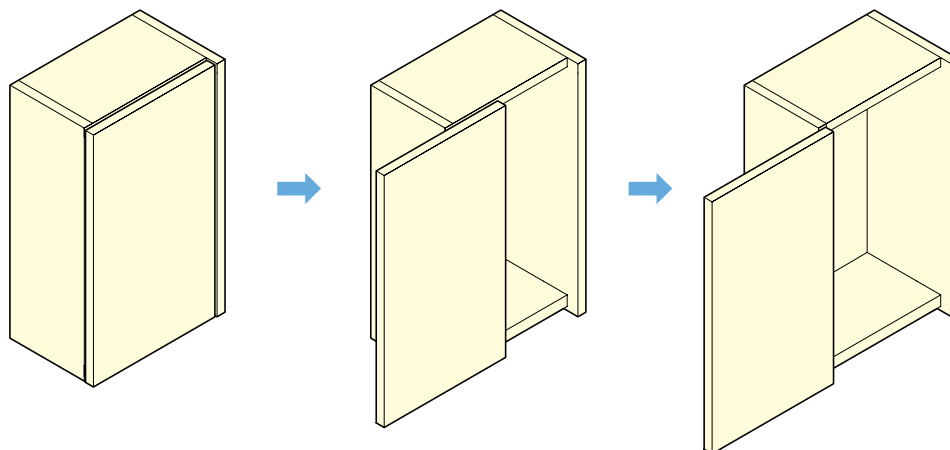
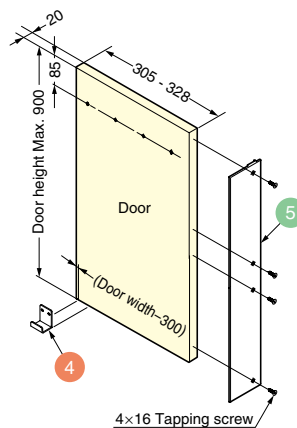
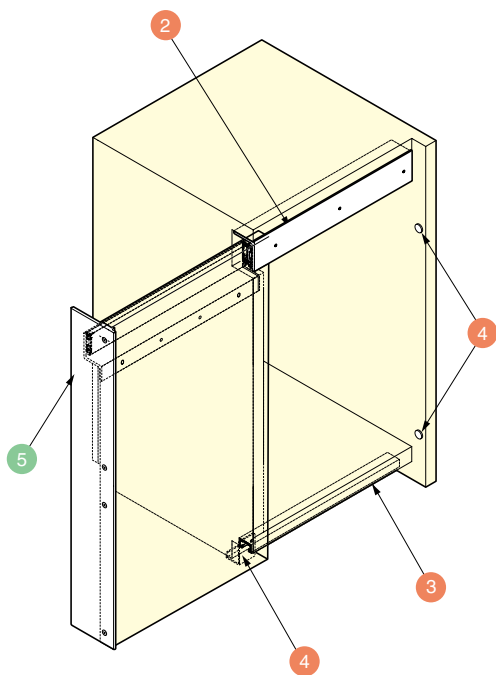
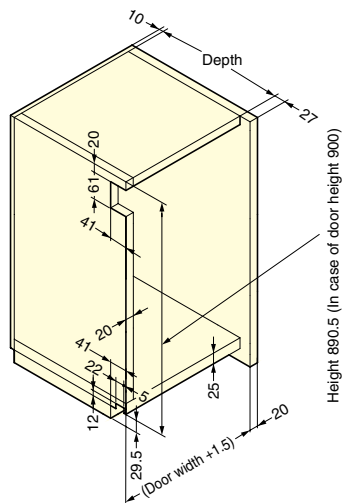

OVER TRAVEL SLIDING DOOR SYSTEM

Installation

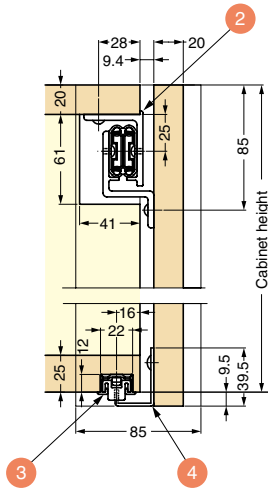
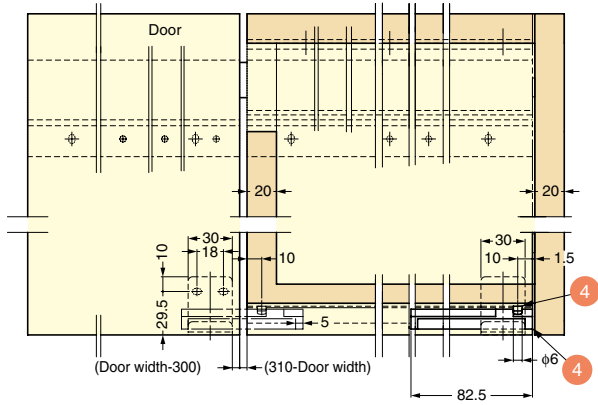

Door width 328 mm

Mounting reference surface

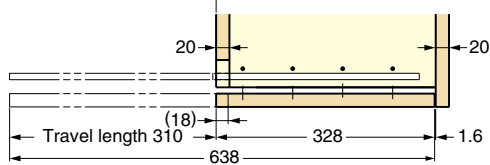

Door width 305 mm

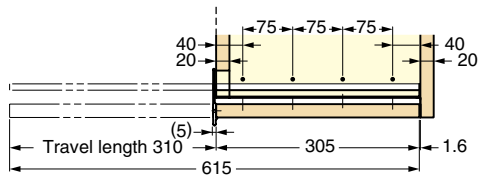

Parts Set (Per Door) Necessary Parts

| Set Name                    | Item Code   | Item Name |
|-----------------------------|-------------|-----------|
| a) Parts Set for Right Open | 250-121-436 | OX-300R   |
| b) Parts Set for Left Open  | 250-121-435 | OX-300L   |

| Items |       |                         |            |  |
|-------|-------|-------------------------|------------|--|
| No.   | Qty   | Part Name               | Dimensions | Description  |
| 1     | 1 pc  | Upper Rail (Right Open) |            | Item Code : 250-121-434<br>Item Name : OX-U300R<br>• Material Aluminium Alloy/Steel<br>• Finish Anodized Silver /Yellow Zinc Chromate  |
| 2     | 1 pc  | Upper Rail (Left Open)  |            | Item Code : 250-121-433<br>Item Name : OX-U300L<br>• Material Aluminium Alloy/Steel<br>• Finish Anodized Silver /Yellow Zinc Chromate  |
| 3     | 1 pc  | Bottom Rail (305 mm)    |            | Item Code : 250-121-431<br>Item Name : OX-L300<br>• Material Aluminium Alloy<br>• Finish Anodized Silver   |
| 4     | 1 set | Parts Set               |            | Item Code : 250-121-432<br>Item Name : OX-P<br>• Parts Included:<br>Bottom guide, Slider, Stopper, Bumper, Screw<br>• Truss Head Tapping Screw 4x18.....4 pcs<br>• Truss Head Tapping Screw 4x16.....6 pcs<br>• Countersunk Head Tapping Screw 3x12.....2 pcs<br>• Round Head Wood Screw 3.5x16.....2 pcs<br>• Countersunk Head Tapping Screw 4x16.....5 pcs |

Optional Parts

| No. | Item Code   | Part Name | Dimensions | Description   |
|-----|-------------|-----------|------------|---|
| 5   | 250-121-430 | Cover     |            | • Material Aluminium Alloy<br>• Finish Anodized Silver<br>• Length 900 mm |

WARDROBE & CABINET DOOR HARDWARE

OVER TRAVEL SLIDING DOOR SYSTEM



# XL-GC SERIES (FOR SLIDING DOORS)



|                 |                        |
|-----------------|------------------------|
| Door Width      | Max. 500 mm            |
| Door Height     | Max. 1200 mm           |
| Glass Thickness | 8 mm                   |
| Glass Weight    | Max. 12 kg / Door      |
| Door Type       | ☐ 2 Sliding Inset Door |

Total solution for coherent design of glass showcase

**Features**

See the cut out dimensions in P.642.

WARDROBE & CABINET DOOR HARDWARE FOR GLASS DOORS XL-GC SERIES

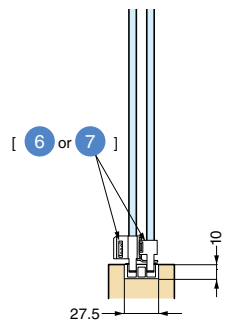
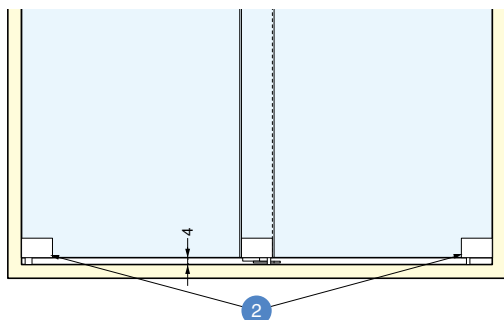
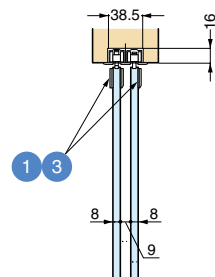
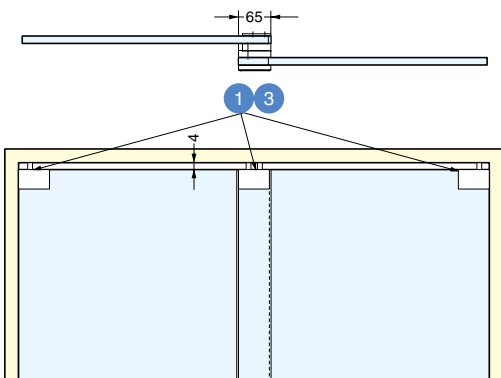
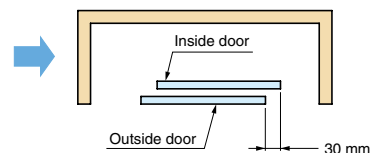
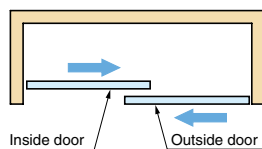
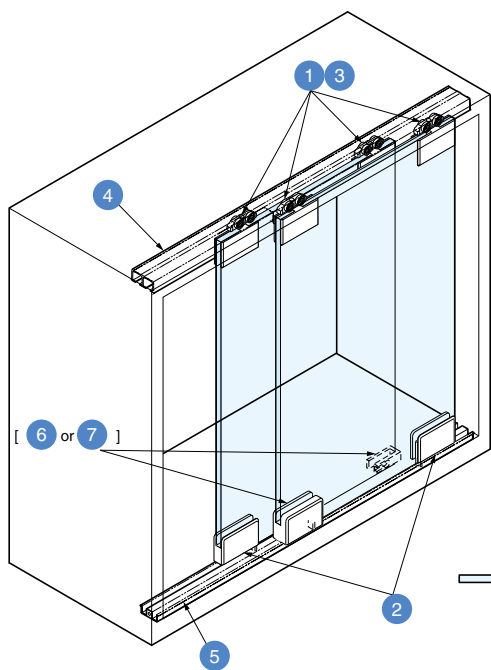

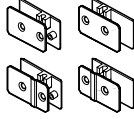
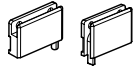
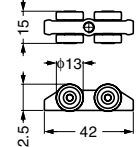
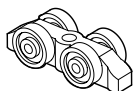
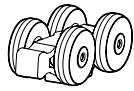
| Sliding Door Parts |   | Necessary Parts   |   |  |
|--------------------|---|---|---|--|
|                    |   | For 2 sliding doors, ① 1 set, ② 1 set and ③ 4 pcs are necessary.                  |   |  |
| No.                | Item Code   | Part Name   | Dimensions  | Description  |
| ①                  | 250-121-960   | Upper Bracket (with Hanger Bolt)  | See Dimension in P.642  | <ul style="list-style-type: none"> <li>Material: Zinc Alloy (ZDC)</li> <li>Finish: Chrome</li> </ul>   |
|                    | XL-GC06-CR  |  |   |  |
| ②                  | 250-121-961   | Bottom Guide  | See Dimension in P.642  | <ul style="list-style-type: none"> <li>Material: Zinc Alloy (ZDC)</li> <li>Finish: Chrome</li> </ul>   |
|                    | XL-GC08-CR  |  |   |  |
| ③                  | 250-120-688   | Roller (drawing 1)  | (drawing 1)  | <ul style="list-style-type: none"> <li>Material: Zinc Alloy (ZDC)</li> <li>Body: Zinc Alloy (ZDC)</li> <li>Roller: Polyacetal (POM)</li> </ul> |
|                    | 53-3061-081   |  |   |  |
|                    | 250-037-471   | (drawing 2)   |   |  |
| 57-3149-071        |  |   |   |  |

When the current stock of the roller ③ and upper rail ④ run out, their item names, codes, and shapes respectively will change to the specs featured in drawing 2. Please note that the old type and the new type can not be used together.

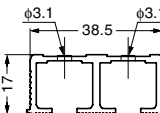
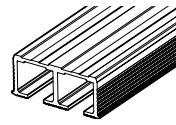
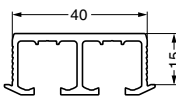
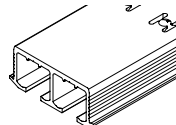
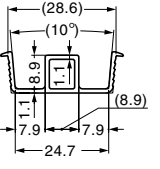
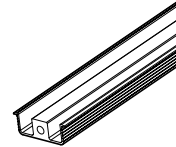
| Rail |                 | Necessary Parts  |  |   |
|------|-----------------|--|--|---|
|      |                 | ④ 1 pc and ⑤ 1 pc  |  |   |
| No.  | Item Code       | Part Name  | Dimensions   | Description   |
| ④    | 250-012-117     | Upper Rail (1200 mm)<br>(drawing 1)  | (drawing 1)   | <ul style="list-style-type: none"> <li>Material: Aluminium Alloy</li> <li>Finish: Plain</li> </ul>    |
|      | XL-GC06-UL1200  | <br>Pitch End : 50 mm<br>Pitch : 150 mm |  |   |
| ⑤    | 250-037-472     | (drawing 2)  | (drawing 2)  | <ul style="list-style-type: none"> <li>Material: Aluminium Alloy</li> <li>Finish: Anodized</li> </ul> |
|      | XL-GC06-UL1200N | <br>Pitch End : 75 mm<br>Pitch : 150 mm |  |   |
| ⑤    | 250-121-962     | Bottom Rail (1200 mm)  |              | <ul style="list-style-type: none"> <li>Material: ABS</li> <li>Finish: Black</li> </ul>                |
|      | XL-GC03-GL1200  |   |  |   |

When the current stock of the roller ③ and upper rail ④ run out, their item names, codes, and shapes respectively will change to the specs featured in drawing 2. Please note that the old type and the new type can not be used together.

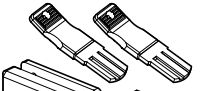
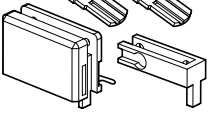
| Sliding Door Lock |                                 | Necessary Parts   |                        |  |
|-------------------|---------------------------------|---|------------------------|--|
|                   |                                 | ⑥ or ⑦ 1 pc   |                        |  |
| No.               | Item Code                       | Part Name   | Dimensions             | Description  |
| ⑥                 | 150-061-103                     | Sliding Door Lock   | See Dimension in P.642 | <ul style="list-style-type: none"> <li>Material: Zinc Alloy (ZDC)</li> <li>Finish: Chrome</li> <li>Max. 24 key changes available.</li> </ul> |
|                   | XL-GC03-CR-B<br>(Key Different) |  |                        |  |
| ⑦                 | 150-001-055                     |  |                        |  |
|                   | XL-GC03-CR-D<br>(Key Alike)     |   |                        |  |

## UPPER BRACKET



## XL-GC06



## Features

- Upper bracket for glass sliding door.
- Can be used with XL-GC03.

| No | Part Name | Material                 | Finish/Colour       |
|----|-----------|--------------------------|---------------------|
| ①  | Body      | Zinc Alloy (ZDC)         | Chrome              |
| ②  | Backplate | Steel                    | Chrome              |
| ③  | Spacer    | Rubber                   | Natural             |
| ④  | Screws    | Stainless Steel (SUS304) | Plain               |
| ⑤  | Bolt      | Steel                    | Clear Zinc Chromate |

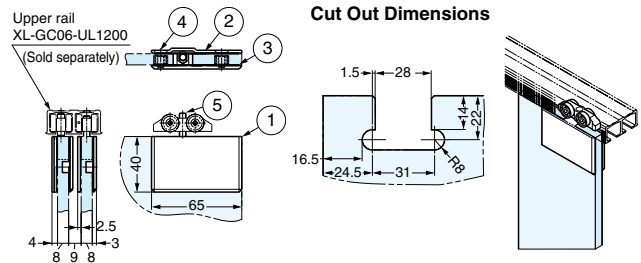

| Item Code   | Item Name  | Glass Thickness | Load Capacity | Weight      | Box   | Carton        |
|-------------|------------|-----------------|---------------|-------------|-------|---------------|
| 250-121-960 | XL-GC06-CR | 8               | 117.7 N/door  | 12 kgf/door | 400 g | 1 pc / 24 pcs |

## BOTTOM GUIDE BRACKET

## XL-GC08



## Features

- Bottom bracket for glass sliding door.
- Can be used with XL-GC03.

| No | Part Name    | Material                 | Finish/Colour |
|----|--------------|--------------------------|---------------|
| ①  | Body (Left)  | Zinc Alloy (ZDC)         | Chrome        |
| ②  | Body (Right) | Zinc Alloy (ZDC)         | Chrome        |
| ③  | Spacer       | Rubber                   | Black         |
| ④  | Screws       | Stainless Steel (SUS304) | Plain         |

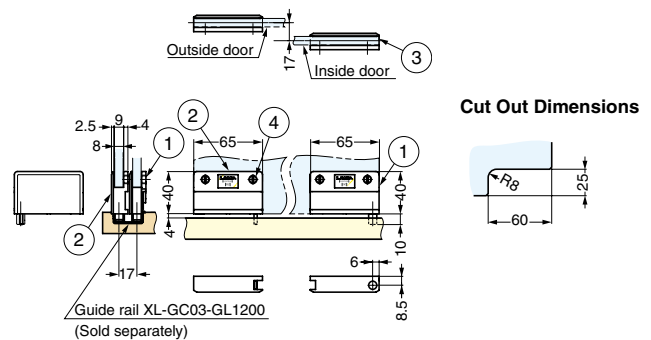

| Item Code   | Item Name  | Glass Thickness | Weight | Box  | Carton |
|-------------|------------|-----------------|--------|------|--------|
| 250-121-961 | XL-GC08-CR | 8               | 400 g  | 1 pc | 24 pcs |

## GLASS DOOR LOCK FOR SLIDING DOOR

## XL-GC03



## Features

- Non-handed. Key hole located on the right side for a clean appearance and high security.
- 24 key numbers available.

## Remarks

Please order 1 pc for 2 doors.

## Option

XL-GC03-GL1200  
(P.641)

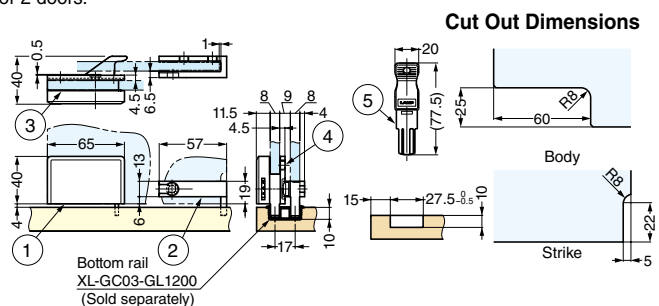

| No | Part Name | Material                 | Finish/Colour |
|----|-----------|--------------------------|---------------|
| ①  | Body      | Zinc Alloy (ZDC)         | Chrome        |
| ②  | Strike    | Zinc Alloy (ZDC)         | Chrome        |
| ③  | Spacer    | Rubber                   | Black         |
| ④  | Screws    | Stainless Steel (SUS304) | Plain         |
| ⑤  | Key       | Brass/ABS                | Nickel/Black  |

| Item Code   | Item Name    | Key Type      | Glass Thickness | Weight | Box  | Carton |
|-------------|--------------|---------------|-----------------|--------|------|--------|
| 150-061-103 | XL-GC03-CR-B | Key Different | 8               | 400 g  | 1 pc | 24 pcs |
| 150-001-055 | XL-GC03-CR-D | Key Alike     | 8               | 400 g  | 1 pc | 24 pcs |

**RUNNER FOR SLIDING DOOR**

**ASDF-1**

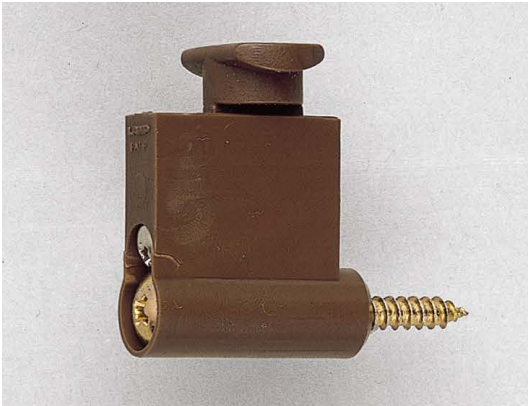

|                     |                  |
|---------------------|------------------|
| Door Thickness      | 16 - 20 mm       |
| Door Weight         | Max. 4 kg        |
| Vertical Adjustment | 3 mm             |
| Door Type           | 2 Panels (Inset) |

**Features**

- Inset type.
- Adjustable for door height.
- Upper Rail also available (Sold Separately).

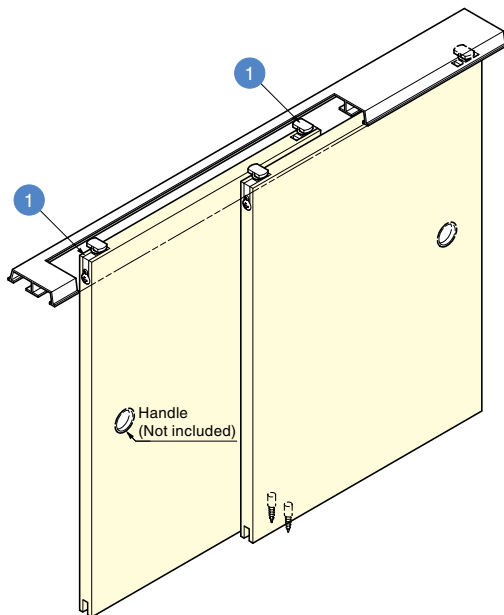

| No. | Item Code         | Part Name            | Dimensions | Description   |
|-----|-------------------|----------------------|------------|---|
| 1   | 250-120-075       | Runner               |            | 2 pcs per door are necessary.<br>• Material Plastic<br>• Colour Brown |
|     | Item Name: ASDF-1 |                      |            |   |
| 2   | 250-129-035       | Upper Rail (1820 mm) |            | • Material Polyvinyl Chlorides<br>• Colour Brown                      |
|     | Item Name: GR1820 |                      |            |   |

Bottom guide and handle are not included.

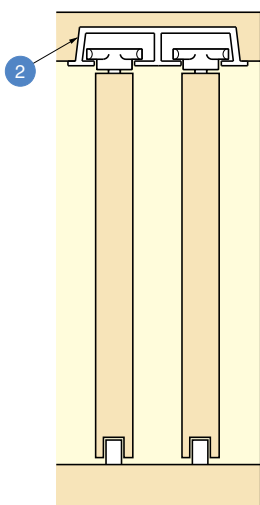

Upper rail 2  
Mortise dimension  
Width 52.2  
Depth 11.5

**Installation**

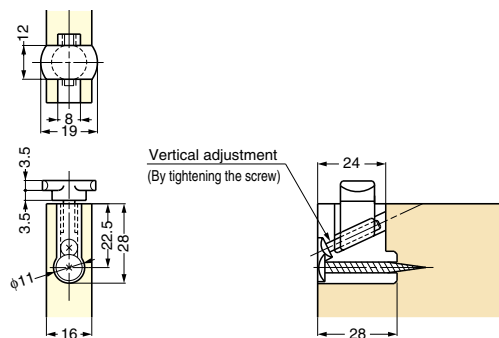

**Cut Out Dimensions**

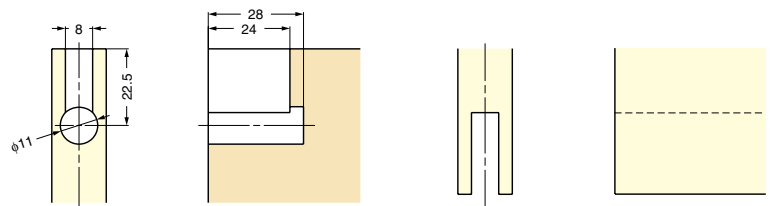





Door Width

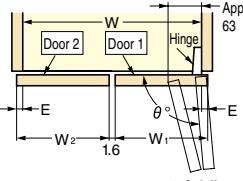
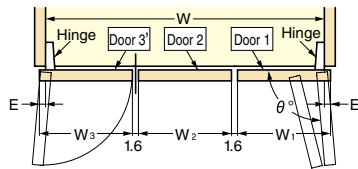
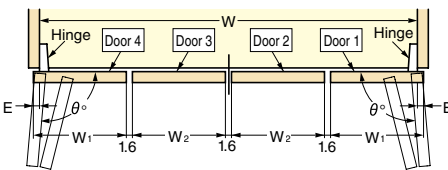

| Application   | Pivot Side Door at 90° Open  | Pivot Side Door at 95° Open   | Same Door Width<br>Pivot Side Door at 87° Open                        |
|---|--|---|---|
|  <p>Approx. 63</p> <p>W : Width of inside cabinet<br/>                     W<sub>1</sub> : Width of Door 1 and Door 4<br/>                     W<sub>2</sub> : Width of Door 2 and Door 3<br/>                     W<sub>3</sub> : Width of Door 3<br/>                     E : Coverage<br/>                     θ° : Opening angle at pivot side door</p> <p>2 folding doors</p> | $W_1 = \frac{W+2E-4.8}{2}$ $W_2 = W_1 + 3.2$   | $W_1 = \frac{W+2E-7.8}{2}$ $W_2 = W_1 + 6.2$  | $W_1 = \frac{W+2E-1.6}{2}$ $W_2 = W_1$ <p>Opening Angle=87°</p>       |
|  <p>2 folding doors+1 swing door</p>   | <ul style="list-style-type: none"> <li>• W<sub>3</sub>=W<sub>1</sub><br/> <math display="block">W_1 = W_3 = \frac{W+2E-6.4}{3}</math> <math display="block">W_2 = W_1 + 3.2</math></li> <li>• W<sub>3</sub>=W<sub>2</sub><br/> <math display="block">W_1 = \frac{W+2E-9.6}{3}</math> <math display="block">W_2 = W_3 = W_1 + 3.2</math></li> </ul> | <ul style="list-style-type: none"> <li>• W<sub>3</sub>=W<sub>1</sub><br/> <math display="block">W_1 = W_3 = \frac{W+2E-9.4}{3}</math> <math display="block">W_2 = W_1 + 6.2</math></li> <li>• W<sub>3</sub>=W<sub>2</sub><br/> <math display="block">W_1 = \frac{W+2E-15.6}{3}</math> <math display="block">W_2 = W_3 = W_1 + 6.2</math></li> </ul> | $W_1 = \frac{W+2E-3.2}{3}$ $W_1 = W_2 = W_3$ <p>Opening Angle=87°</p> |
|  <p>2 folding doors+2 folding doors</p>  | $W_1 = \frac{W+2E-11.2}{4}$ $W_2 = W_1 + 3.2$  | $W_1 = \frac{W+2E-17.2}{4}$ $W_2 = W_1 + 6.2$   | $W_1 = \frac{W+2E-4.8}{4}$ $W_1 = W_2$ <p>Opening Angle=87°</p>       |

WARDROBE & CABINET DOOR HARDWARE

Slide Guide  
Concealed Hinge  
Mounting Plate  
Centre Hinge  
Rail

Necessary Parts

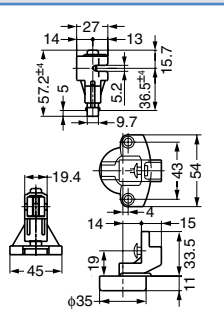
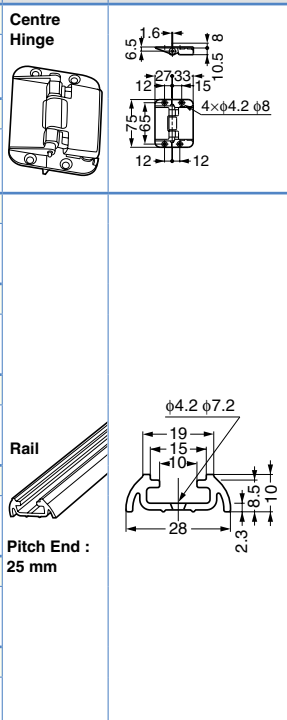
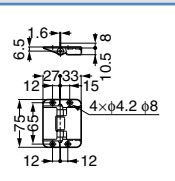
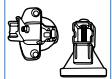
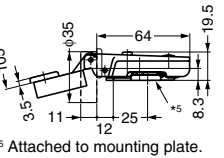
① 2 pcs are necessary for a pair of doors. Please order necessary qty of ②, ③ and ④ / ⑤ based on door height (refer to chart on P.644). Please order suitable rail ⑥ - ⑪ for the application.

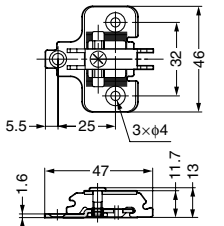
| No. | Item Code   | Part Name   | Dimensions  | Description   | No.   | Item Code                   | Part Name                    | Dimensions  | Description  |
|-----|-------------|---|---|---|---|-----------------------------|------------------------------|---|--|
| ①   | 250-120-029 | Sliding Guide   |                                        | <ul style="list-style-type: none"> <li>• Material Zinc Alloy (ZDC) Polyacetal (POM)</li> <li>• Finish Nickel</li> <li>• Body: Nickel</li> </ul> |  <p>Rail</p> <p>Pitch End : 25 mm</p> | 250-129-208                 | Centre Hinge                 |  | <ul style="list-style-type: none"> <li>• Material Zinc Alloy (ZDC) Polyamide (PA) Polyacetal (POM)</li> <li>• Hinge Axis: Steel</li> <li>• Finish Body: Nickel (NI) Bronze (GB)</li> </ul> |
|     | FD28-SG     |  | <ul style="list-style-type: none"> <li>④ CH-75NI Nickel</li> <li>⑤ CH-75GB Bronze</li> </ul>                              |   |   |                             |                              |   |  |
| ②   | 160-070-036 | Concealed Hinge   |  <p>*5 Attached to mounting plate.</p> | <ul style="list-style-type: none"> <li>• Material Steel</li> <li>• Finish Nickel</li> </ul>   |   | 250-120-039                 | FD28-910-SIL Silver 910 mm   |   | <ul style="list-style-type: none"> <li>• Material Aluminium Alloy</li> <li>• Finish Anodized/Silver</li> </ul>   |
|     | 230-26/19T  |  |   |   |   | 250-120-037                 | FD28-1220-SIL Silver 1220 mm |   |  |
| ③   | 160-070-041 | Mounting Plate  |                                        | <ul style="list-style-type: none"> <li>• Material Steel</li> <li>• Finish Nickel</li> </ul>   |   | 250-120-035                 | FD28-1820-SIL Silver 1820 mm |   | <ul style="list-style-type: none"> <li>• Material Aluminium Alloy</li> <li>• Finish Anodized/Bronze</li> </ul>   |
|     | 230-P4W-32T | 250-120-038   |   |   |   | FD28-910-GB Bronze 910 mm   |                              |   |  |
|     |             | 250-120-036   |   |   |   | FD28-1220-GB Bronze 1220 mm |                              |   |  |
|     |             | 250-120-034   |   |   |   | FD28-1820-GB Bronze 1820 mm |                              |   |  |
|     |             | 250-120-034   |   |   |   | FD28-1820-GB Bronze 1820 mm |                              |   |  |

FOLDING DOOR SYSTEM

FOLDING DOOR SYSTEM

FD30-F



WARDROBE & CABINET DOOR HARDWARE

FOLDING DOOR SYSTEM

|                | a                                  | b  | c                            | d                          |
|----------------|------------------------------------|--|------------------------------|----------------------------|
| Item Code      | 250-017-905                        | 250-017-908                                    | 250-018-312                  | 250-018-316                |
| Item Name      | FD30FKP                            | FD30UKP  | FD30URP-1P                   | FD30UMP-1P                 |
| Application    | Standard Folding (One Pivot Fixed) | Standard Folding with Roller (One Pivot Fixed) | Slidable (For Partition Use) | Slidable (For Cabinet Use) |
| Door Width     | Max. 450 mm                        |  |                              |                            |
| Door Height    | Max. 2400 mm                       |  |                              |                            |
| Door Thickness | Min. 30 mm                         |  |                              |                            |
| Door Weight    | Max. 15 kg/Door                    |  |                              |                            |

| Parts Set (Per Door)  |             | Necessary Parts |  |
|---|-------------|-----------------|--|
| Please refer to "Qty a - d" for parts included in each set. |             |                 |  |
| Item Code   | Item Name   | Description     |  |
| a   | 250-017-905 | FD30FKP         | For Pivoted Folding Door                 |
| b   | 250-017-908 | FD30UKP         | For Pivoted Folding w/ Roller            |
| c   | 250-018-312 | FD30URP-1P      | For Slidable Folding (For Partition Use) |
| d   | 250-018-316 | FD30UMP-1P      | For Slidable Folding (For Cabinet Use)   |

Parts Included

| No. | Qty  |       |       |       | Part Name                     | Dimensions   | Description |
|-----|------|-------|-------|-------|-------------------------------|--|-------------|
|     | a    | b     | c     | d     |                               |  |             |
| 1   | 1 pc | -     | -     | -     | Upper Pivot                   | Item Code : 250-017-162<br>Item Name : FD30-FTP<br>• Material : Steel / Polyamide<br>• Finish : Chromate / White           |             |
| 2   | 1 pc | -     | -     | -     | Guide Roller                  | Item Code : 250-017-140<br>Item Name : FD30-FGRU<br>• Material : Steel / Polyamide<br>• Finish : Chromate / White, Black   |             |
| 3   | -    | 2 pcs | 2 pcs | -     | Upper Roller (Recessed Mount) | Item Code : 250-026-120<br>Item Name : FD30-WRH<br>• Material : Zinc Alloy Polyacetal<br>• Finish : Chromate / Light Brown |             |
| 4   | -    | -     | -     | 2 pcs | Upper Roller (Side Mount)     | Item Code : 250-017-142<br>Item Name : FD30-WRU<br>• Material : Steel / Polyacetal<br>• Finish : Chromate / Brown          |             |
| 5   | -    | 1 pc  | -     | -     | Stopper Block                 | Item Code : 250-017-139<br>Item Name : FD30-HSB<br>• Material : Polyacetal<br>• Finish : Dark Brown                        |             |
| 6   | 1 pc | 1 pc  | -     | -     | Bottom Pin                    | Item Code : 250-017-163<br>Item Name : FD30-FBP<br>• Material : Steel / Polyacetal<br>• Finish : Chromate / White          |             |
| 7   | -    | -     | 2 pcs | 2 pcs | Guide Pin                     | Item Code : 250-017-164<br>Item Name : FD30-FGR<br>• Material : Steel / Polyacetal<br>• Finish : Chromate / White          |             |
| 8   | 1 pc | 1 pc  | 1 pc  | 1 pc  | Pin Insert Jig                | Item Code : 250-017-169<br>Item Name : FD30-FSJ  |             |
| 9   | 1 pc | 1 pc  | -     | -     | Spanner Wrench                | Item Code : 250-017-168<br>Item Name : FD30-FSP  |             |
| 10  | -    | -     | -     | -     | Top Bracket                   | Item Code : 250-017-165<br>Item Name : FD30-FSK<br>• Material : Steel<br>• Finish : Chromate                               |             |

| No. | Qty   |       |       |       | Part Name  | Dimensions  | Description |
|-----|-------|-------|-------|-------|--|---|-------------|
|     | a     | b     | c     | d     |  |   |             |
| 11  | 1 pc  | -     | -     | -     | Pivot Bracket (Upper)  | Item Code : 250-017-141<br>Item Name : FD30-FSKU<br>• Material : Steel<br>• Finish : Chromate                         |             |
| 12  | 1 pc  | 1 pc  | -     | -     | Pivot Bracket (Bottom)   | Item Code : 250-017-170<br>Item Name : FD30-FPU<br>• Material : Steel<br>• Finish : Chromate                          |             |
| 13  | -     | 1 pc  | -     | -     | Fixing Plate   | Item Code : 250-017-144<br>Item Name : FD30-FKK<br>• Material : Steel<br>• Finish : Chromate                          |             |
| 14  | -     | -     | 2 pcs | 2 pcs | Upper Stopper  | Item Code : 250-017-143<br>Item Name : FD30-FTST-DB<br>• Material : Steel / Polyacetal<br>• Finish : Chromate / Brown |             |
| 15  | -     | -     | -     | 2 pcs | Bottom Stopper   | Item Code : 250-019-297<br>Item Name : FD30-FTST-GR<br>• Material : Steel / Polyacetal<br>• Finish : Chromate / Grey  |             |
| 16  | -     | -     | 2 pcs | 2 pcs | Centre Hinge (Surface Mount, Angle Adjustable)                 | Item Code : 250-017-166<br>Item Name : FD30-FBKS<br>• Material : Steel / Polyacetal<br>• Finish : Chromate / Brown    |             |
| 17  | 3 pcs | 3 pcs | -     | -     | Centre Hinge (Recessed Mount, Angle Adjustable, W/Detent Stop) | Item Code : 250-017-146<br>Item Name : FD30-CHM<br>• Material : Steel<br>• Finish : Chromate / Black                  |             |
| 18  | -     | -     | -     | 3 pcs | Centre Hinge (Door Edge, Angle Adjustable, W/Detent Stop)      | Item Code : 250-019-899<br>Item Name : FD30-CHM-WT<br>• Material : Steel<br>• Finish : Chromate / White               |             |
| 19  | -     | -     | -     | 3 pcs | Centre Hinge (Surface Mount, Angle Adjustable)                 | Item Code : 250-017-147<br>Item Name : FD30-CHH<br>• Material : Steel<br>• Finish : Steel / Black                     |             |
| 20  | -     | -     | -     | 3 pcs | Centre Hinge (Recessed Mount, Angle Adjustable, W/Detent Stop) | Item Code : 250-019-900<br>Item Name : FD30-CHH-WT<br>• Material : Steel<br>• Finish : White                          |             |
| 21  | -     | -     | -     | 3 pcs | Centre Hinge (Door Edge, Angle Adjustable, W/Detent Stop)      | Item Code : 250-017-167<br>Item Name : FD30-CHK<br>• Material : Zinc Alloy<br>• Finish : Dark Brown                   |             |
| 22  | -     | -     | -     | 3 pcs | Centre Hinge (Surface Mount, Angle Adjustable)                 | Item Code : 250-019-901<br>Item Name : FD30-CHK-WT<br>• Material : Zinc Alloy<br>• Finish : White                     |             |

| Upper Track Necessary Parts |                  |        |                 |            | Bottom Guide Track Necessary Parts for <input type="checkbox"/> c <input type="checkbox"/> d         |     |                      |        |                  |            |  |
|-----------------------------|------------------|--------|-----------------|------------|--|-----|----------------------|--------|------------------|------------|--|
| No.                         | Installation     | Length | Item Code       | Dimensions | Description  | No. | Installation         | Length | Item Code        | Dimensions | Description  |
| 23-26                       | Surface Mount    | 910 mm | 250-017-962     |            | <ul style="list-style-type: none"> <li>Material Aluminium</li> <li>Finish Anodized Silver</li> </ul> | 31  | Floor Surface Mount  | 910 mm | 250-018-080      |            | <ul style="list-style-type: none"> <li>Material Aluminium</li> <li>Finish Anodized Silver</li> </ul> |
|                             |                  |        | FD30-TRM910SIL  |            |  |     |                      |        | FD30-FBRM910SIL  |            |  |
|                             |                  |        | 250-017-131     |            |  |     |                      |        | 250-017-160      |            |  |
|                             |                  |        | FD30-TRM1820SIL |            |  |     |                      |        | FD30-FBRM1820SIL |            |  |
|                             |                  |        | 250-017-966     |            |  |     |                      |        | 250-018-082      |            |  |
| FD30-TRM2730SIL             | FD30-FBRM2730SIL |        |                 |            |  |     |                      |        |                  |            |  |
| 250-017-970                 | 250-018-084      |        |                 |            |  |     |                      |        |                  |            |  |
| FD30-TRM3640SIL             | FD30-FBRM3640SIL |        |                 |            |  |     |                      |        |                  |            |  |
| 27-30                       | Recessed Mount   | 910 mm | 250-017-964     |            | <ul style="list-style-type: none"> <li>Material Aluminium</li> <li>Finish Anodized Silver</li> </ul> | 35  | Floor Recessed Mount | 910 mm | 250-018-074      |            | <ul style="list-style-type: none"> <li>Material Aluminium</li> <li>Finish Anodized Silver</li> </ul> |
|                             |                  |        | FD30-TRH910SIL  |            |  |     |                      |        | FD30-FBRH910SIL  |            |  |
|                             |                  |        | 250-017-133     |            |  |     |                      |        | 250-017-158      |            |  |
|                             |                  |        | FD30-TRH1820SIL |            |  |     |                      |        | FD30-FBRH1820SIL |            |  |
|                             |                  |        | 250-017-968     |            |  |     |                      |        | 250-018-076      |            |  |
| FD30-TRH2730SIL             | FD30-FBRH2730SIL |        |                 |            |  |     |                      |        |                  |            |  |
| 250-017-972                 | 205-018-078      |        |                 |            |  |     |                      |        |                  |            |  |
| FD30-TRH3640SIL             | FD30-FBRH3640SIL |        |                 |            |  |     |                      |        |                  |            |  |

| Cover Cap Necessary Parts for <input type="checkbox"/> b <input type="checkbox"/> c |                 |                            |              |   |  |
|---|-----------------|----------------------------|--------------|---|--|
| No.   | Item Code       | Item Name                  | Installation | Description   |  |
| 39  | 250-018-785     | Cover Cap for Upper Roller |              | End Cap (For Roller 3)  | <ul style="list-style-type: none"> <li>Material Polypropylene</li> <li>Finish White</li> </ul>       |
|   | FD30-WRH-CP-WT  |                            |              |   | <ul style="list-style-type: none"> <li>Material Polypropylene</li> <li>Finish Light Brown</li> </ul> |
| 250-017-138   | FD30-WRH-CP-LBR |                            |              |   |  |
| 41  | 250-018-786     | FD30-WRH-CP-DB             |              | <ul style="list-style-type: none"> <li>Material Polypropylene</li> <li>Finish Dark Brown</li> </ul> |  |

| Centre Hinge Necessary Parts |             |              |                          |        |           |
|------------------------------|-------------|--------------|--------------------------|--------|-----------|
| No.                          | Item Code   | Installation | Angle Adjustment         | Detent |           |
| 17                           | 250-017-146 |              | Surface Mount            |        | 37° Angle |
|                              | FD30-CHM    |              |                          |        |           |
| 18                           | 250-019-899 |              | Recessed Mount           |        | 50° Angle |
|                              | FD30-CHM-WT |              |                          |        |           |
| 19                           | 250-017-147 |              | Door Edge Recessed Mount |        | 47° Angle |
|                              | FD30-CHH    |              |                          |        |           |
| 20                           | 250-019-900 |              | Door Edge Recessed Mount |        | 47° Angle |
|                              | FD30-CHH-WT |              |                          |        |           |
| 21                           | 250-017-167 |              | Door Edge Recessed Mount |        | 47° Angle |
|                              | FD30-CHK    |              |                          |        |           |
| 22                           | 250-019-901 |              | Door Edge Recessed Mount |        | 47° Angle |
|                              | FD30-CHK-WT |              |                          |        |           |

| Optional Parts |             |              |  |             |  |
|----------------|-------------|--------------|--|-------------|--|
| No.            | Item Code   | Installation | Description  | Description |  |
| 42             | 250-017-171 |              | Guide Pin (Magnetic)   |             | <ul style="list-style-type: none"> <li>Material Polycarbonate</li> <li>Neodymium</li> <li>Finish Dark Brown</li> </ul> |
|                | FD30-FMF    |              |  |             |  |
| 43             | 250-017-173 |              | Guide Pin (Pin)  |             | <ul style="list-style-type: none"> <li>Material Polyamide / Steel</li> <li>Finish White / Chromate</li> </ul>          |
|                | FD30-FTF    |              |  |             |  |
| 44             | 250-017-172 |              | Latch Unit (To be Used When Ordering <input type="checkbox"/> c, <input type="checkbox"/> d) |             | <ul style="list-style-type: none"> <li>Material Polyacetal</li> <li>Finish Dark Brown</li> </ul>                       |
|                | FD30-FHL    |              |  |             |  |

WARDROBE & CABINET DOOR HARDWARE

FOLDING DOOR SYSTEM

**a Pivoted Folding Door - Surface Mount Hinge**

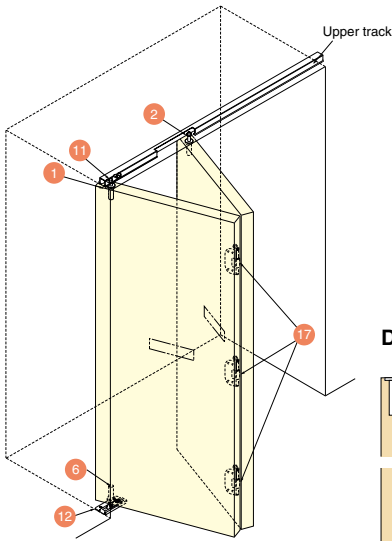

**Door Preparation**

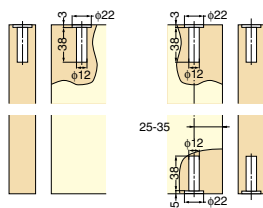

**Gap Required - Door and Frame**

| Door Thickness | Gap C Min. | Gap E Min. in Case D=30 |           |           |           |
|----------------|------------|-------------------------|-----------|-----------|-----------|
|                |            | Width 300               | Width 350 | Width 400 | Width 450 |
| 30             | 4.0        | 3.5                     | 3.0       | 2.7       | 2.4       |
| 35             | 5.2        | 4.3                     | 3.7       | 3.3       | 3.0       |
| 40             | 6.5        | 5.2                     | 4.5       | 4.0       | 3.6       |

**Features**

Centre Hinge has angle adjustment, detent stop feature and is mounted on surface at back side of door for easy installation.

**Installation Example (In case of 40 mm thick, 450 mm wide door)**

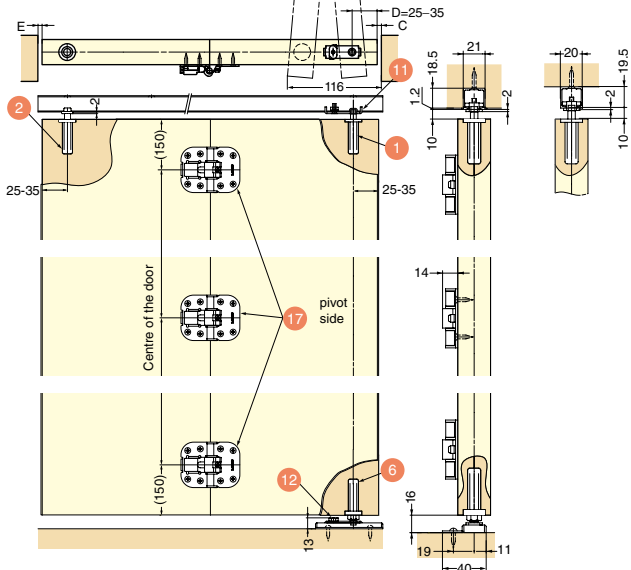

**b Pivoted Folding Door (With Roller) - Surface Mount Hinge**

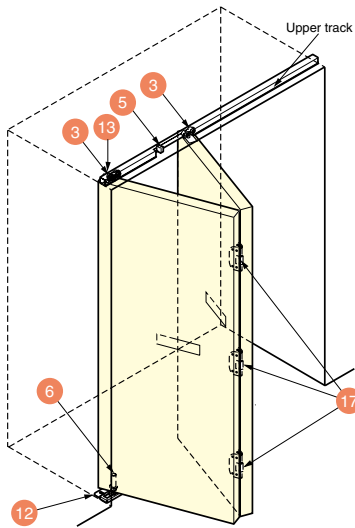

**Door Preparation**

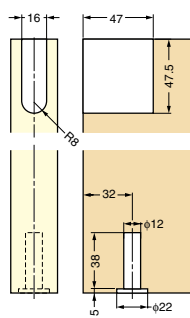

**Gap Required - Door and Frame**

| Door Thickness | Gap C Min. | Gap E Min. in Case D=30 |           |           |           |
|----------------|------------|-------------------------|-----------|-----------|-----------|
|                |            | Width 300               | Width 350 | Width 400 | Width 450 |
| 30             | 4.0        | 3.5                     | 3.0       | 2.7       | 2.4       |
| 35             | 5.2        | 4.3                     | 3.7       | 3.3       | 3.0       |
| 40             | 6.5        | 5.2                     | 4.5       | 4.0       | 3.6       |

**Features**

Centre Hinge has angle adjustment, detent stop feature and is mounted on surface at back side of door for easy installation.

**Installation Example (In case of 40 mm thick, 450 mm wide door)**

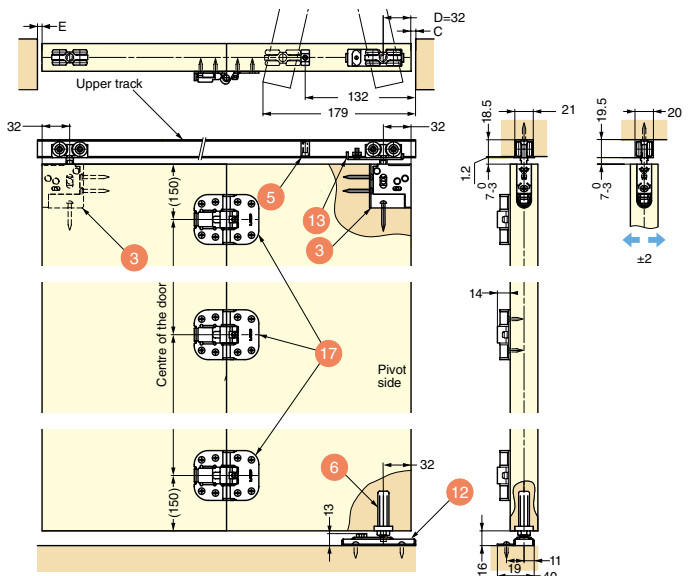



LAMP® SOFT-CLOSE FOLDING DOOR SYSTEM



SFD



|                |                            |
|----------------|----------------------------|
| Door Width     | 380-460mm                  |
| Door Height    | Max. 2600mm                |
| Door Thickness | 18-30mm                    |
| Door Weight    | Max. 8kg (Per door) *1     |
| Door Type      | Bi-Folding Doors (Overlay) |

\*1 Please prioritize door weight when selecting doors.

No guide rail on top or bottom, outfitted with soft-close mechanism.

Features

- When door is within a certain range, the door will automatically close itself due to its built-in mechanism.
- No rail on top or bottom makes installation easy.
- Door can be adjusted after installation because of concealed hinges.

Remarks

- For the top and bottom concealed hinges, please place them 100mm from the edge. (Place the middle hinge equidistance from the others)
- The bi-fold door hinge should be evenly placed depending on the doors height.
- If you are using a hinge besides the H230, please contact our sales department for more information.

WARDROBE & CABINET DOOR HARDWARE



Body

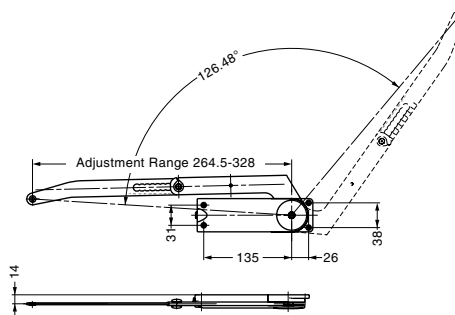

Dimension

The circled numbers are referenced on the next page.

The picture below shows a right opening door. A left opening door would be the opposite set up.

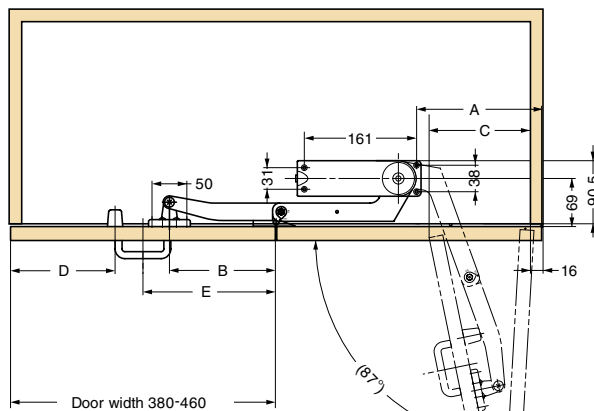
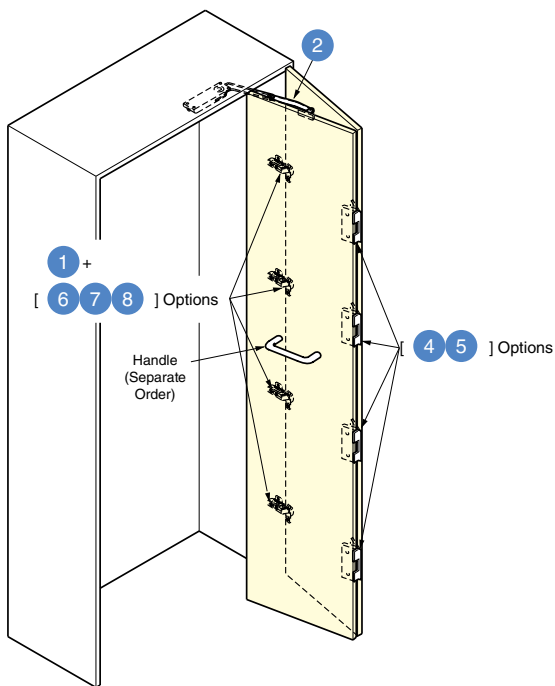

The picture features SFD-3L-R (right opening type).

The installation above is for a half overlay hinge.

The above installation can be used for a full overlay hinge.

For use with an inset hinge, please contact us directly for more information.

\*2 Install the handle between the bi-fold door hinge and the position specified in column E (below)

| Door Width | Available Range | Adjustable Position | A     | B   | C     | D     | E     |
|------------|-----------------|---------------------|-------|-----|-------|-------|-------|
| 380        | 375-385         | 1                   | 179.5 | 152 | (145) | (150) | (190) |
| 390        | 385-395         | 2                   | 184.5 | 155 | (150) | (155) | (195) |
| 400        | 395-405         | 3                   | 189.5 | 158 | (154) | (160) | (200) |
| 410        | 405-415         | 4                   | 194.5 | 161 | (158) | (165) | (205) |
| 420        | 415-425         | 5                   | 199.5 | 164 | (162) | (170) | (210) |
| 430        | 425-435         | 6                   | 204.5 | 167 | (168) | (170) | (215) |
| 440        | 435-445         | 7                   | 209.5 | 170 | (172) | (175) | (220) |
| 450        | 445-455         | 8                   | 214.5 | 173 | (177) | (180) | (225) |
| 460        | 455-465         | 9                   | 219.5 | 176 | (181) | (180) | (230) |

FOLDING DOOR SYSTEM

Door Movement

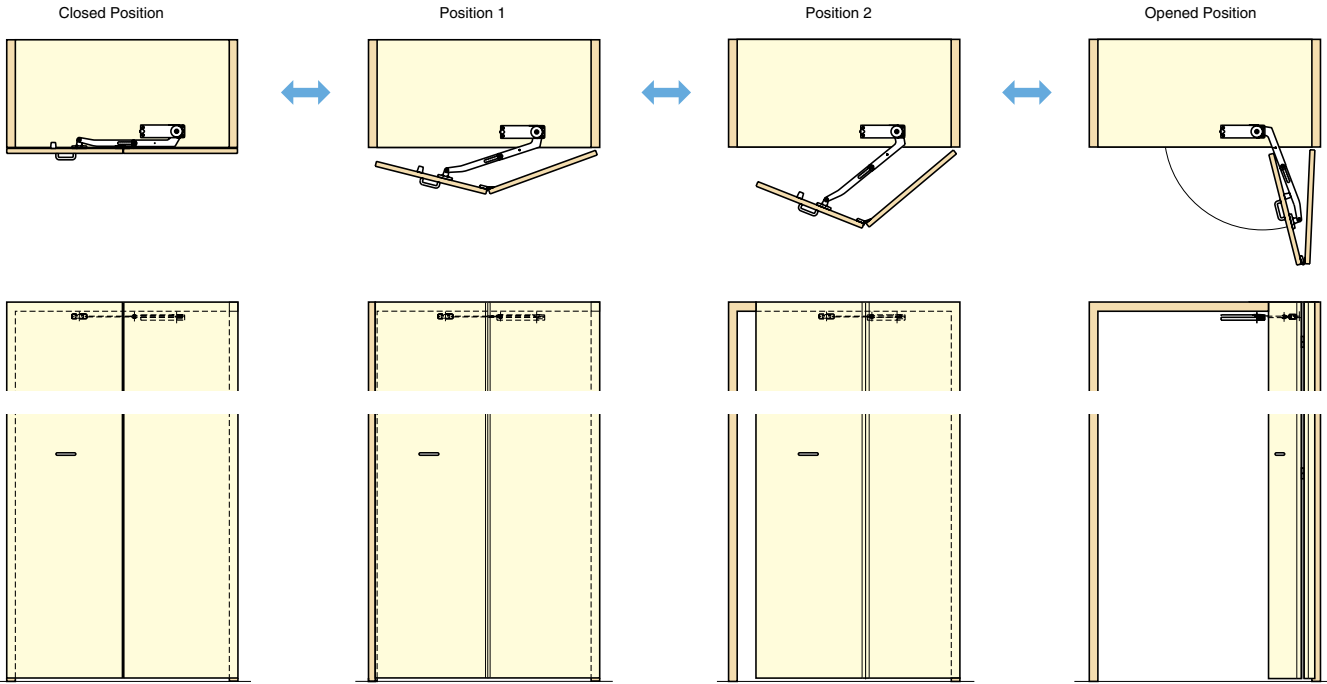

How to order the Soft-Close Folding Door System SFD

• When ordering..... Mounting Plate + Body / Bi-Fold Door Hinge / Hinge

WARDROBE & CABINET DOOR HARDWARE

FOLDING DOOR SYSTEM

Mounting Plate



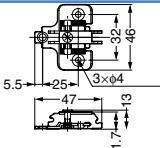





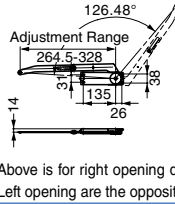

Required for every order. Please refer to the table below for number of hinges required.

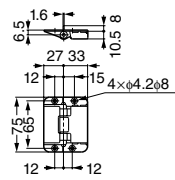
| No. | Item Code                                 | Part  | Dimensions  | Finish                                |
|-----|---|---|---|---------------------------------------|
| 1   | 160-070-041<br>[Item Name]<br>230-P4W-32T | Mounting Plate<br> |  | • Material: Steel<br>• Finish: Nickel |

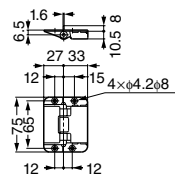
Body - Bi-Fold Door Hinge - Hinge

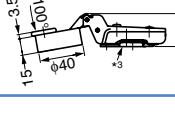
Please read the following and confirm which parts are necessary for installation.

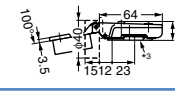
Select 2 or 3 based on the opening direction of the door. Choose between 4 and 5 bi-fold door hinges. Choose between 6, 7 and 8 concealed hinges depending on inset or overlay. Use the list on the bottom left hand of this page to find the number of hinges required for installation.

| No. | Type            | Item Code                                 | Parts   | Dimension   | Finish   |
|-----|-----------------|---|---|---|--|
| 2   | Right Open Type | 250-100-391<br>[Item Name]<br>SFD-3L-R    | Body<br>               | <br>Adjustment Range: 126.48°, 264.5-328 | • Main materials: ABS Resin, Steel<br>• Finish/Color: Nickel, Light Gray                             |
| 3   | Left Open Type  | 250-100-390<br>[Item Name]<br>SFD-3L-L    |                        | Above is for right opening door. Left opening are the opposite.   |  |
| 4   | Nickel          | 250-129-208<br>[Item Name]<br>CH-75NI     | Bi-Fold Door Hinge<br> |    | • Material: Body: ZDC, Plastic: Polyamide(PA) / Polyacetyl<br>• Finish: Body: Nickel, Plastic: Brown |
| 5   | Bronze          | 250-120-031<br>[Item Name]<br>CH-75GB     |                        |    | • Material: Body: ZDC, Plastic: Polyamide(PA) / Polyacetyl<br>• Finish: Body: Bronze, Plastic: Brown |
| 6   | Overlay         | 160-079-414<br>[Item Name]<br>H230-26/16T | Concealed Hinge<br>    |    | • Material: Steel<br>• Finish: Nickel  |
| 7   |                 | 160-079-413<br>[Item Name]<br>H230-26/26T | Concealed Hinge<br>    |    |  |
| 8   | Inset           | 160-079-415<br>[Item Name]<br>H230-26/0T  | Concealed Hinge<br>    |    |  |

Required number of concealed hinges 6, 7, 8, and bi-fold door hinges 4, 5 for installation.

| Door Height   | Bi-Fold Door Hinge 4, 5 | Hinge 6, 7, 8 | Mounting Plate 1 |
|---------------|-------------------------|---------------|------------------|
| 500mm or less | 2 pcs.                  | 2 pcs.        | 2 pcs.           |
| 500-1000mm    | 2 pcs.                  | 3 pcs.        | 3 pcs.           |
| 1000-1500mm   | 3 pcs.                  | 4 pcs.        | 4 pcs.           |
| 1500-2000mm   | 4 pcs.                  | 5 pcs.        | 5 pcs.           |
| 2000-2600mm   | 4 pcs.                  | 6 pcs.        | 6 pcs.           |

\*3 This illustration is of an attached hinge.

# ROTATING CABINET SYSTEM



# RB-600



|                |  |
|----------------|--|
| Cabinet Width  | Max. 680 mm  |
| Cabinet Height | Max. 1925 mm   |
| Overall Height | RB-600-NC...Cabinet Height+230 mm<br>RB-600-ST ...Cabinet Height+435 mm<br>RB-600-CH...Cabinet Height+660 mm |
| Cabinet Depth  | 300 mm   |
| Load Capacity  | 740 N (75.5 kgf) (Including Cabinet Weight)  |

**Features**

- Innovative "reversible" cabinet system rotates 180° for easy access to both sides.
- 3 model types available: Inset Wall Type (NC), Floor Type (ST), and Floor-to-Ceiling Type (CH).
- Stainless steel frame can be cut in height to accommodate cabinets of various heights.
- Useful for a variety of storage and display installations in residential and retail settings.

[Video Link](#)



**Application Example**

Bathroom cabinet, living room, kitchen, dressing room, store etc.

**Remarks**

Please use the special tool Z059 (sold separately for proper installation).

**Cabinet Dimensions**

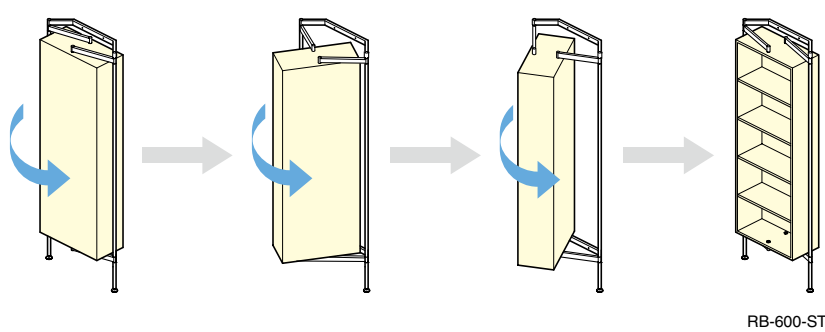
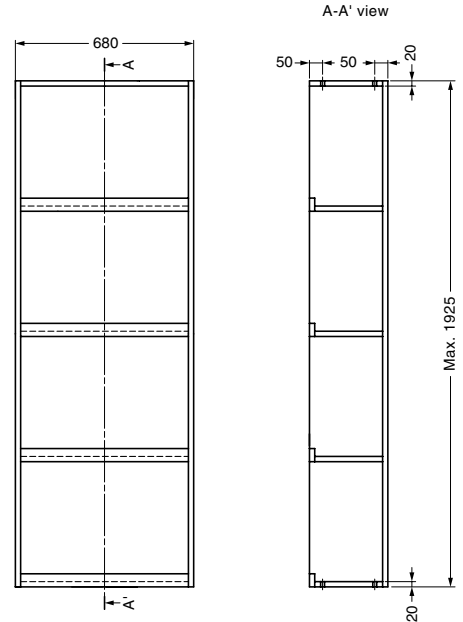
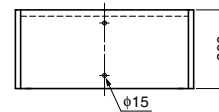

**Rotating Dimensions (cabinet width 680 mm)**

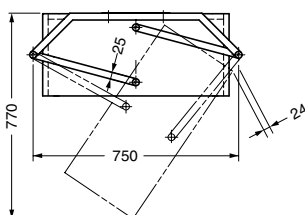

**Body**

| Item Code   | Item Name | Type                    | Material                 | Finish |
|-------------|-----------|-------------------------|--------------------------|--------|
| 110-022-225 | RB-600-NC | Inset Wall/Cabinet Type | Stainless Steel (SUS304) | Satin  |
| 110-022-224 | RB-600-ST | Floor Type              | Stainless Steel (SUS304) | Satin  |
| 110-022-223 | RB-600-CH | Floor-to-ceiling Type   | Stainless Steel (SUS304) | Satin  |

**Exclusive Tool (Sold Separately)**

| Item Code   | Item Name |
|-------------|-----------|
| 270-180-388 | Z059      |



WARDROBE & CABINET DOOR HARDWARE

ROTATING CABINET SYSTEM



Installation Example

RB-600-NC Inset wall/cabinet type

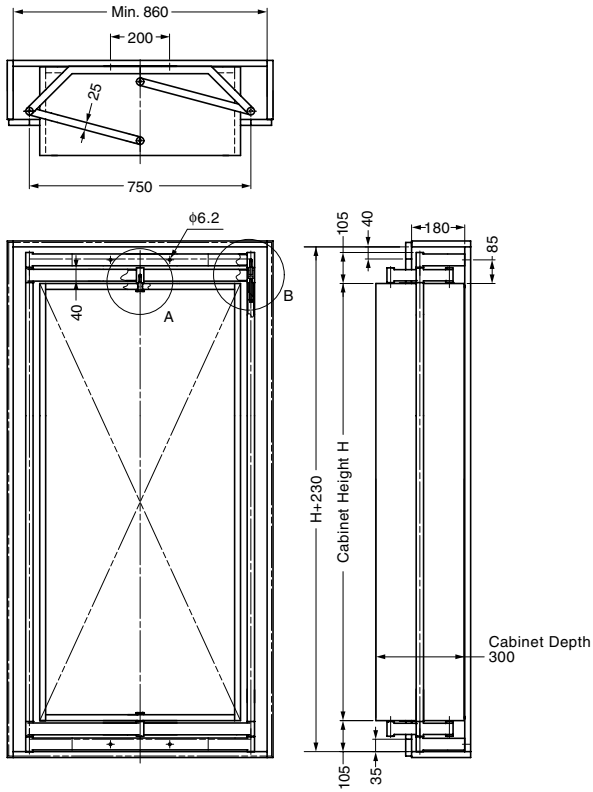

RB-600-ST Floor type

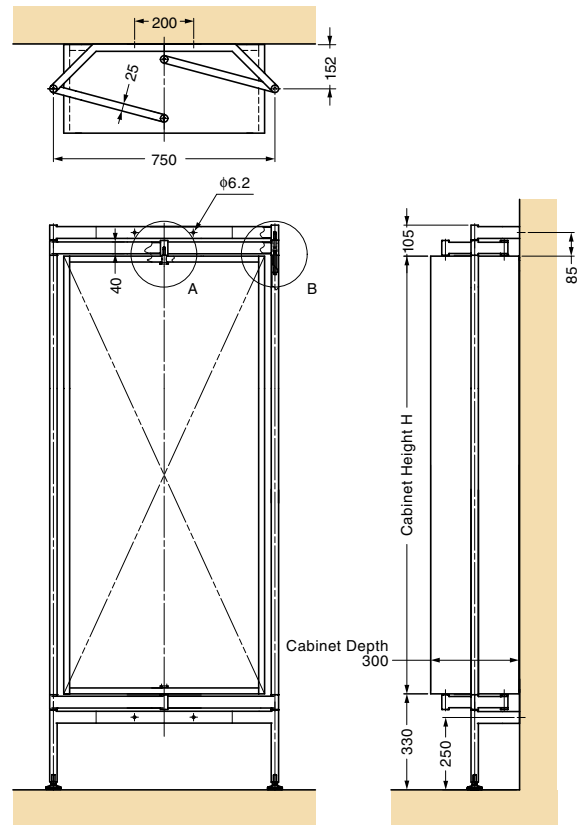

RB-600-CH Floor-to-ceiling type

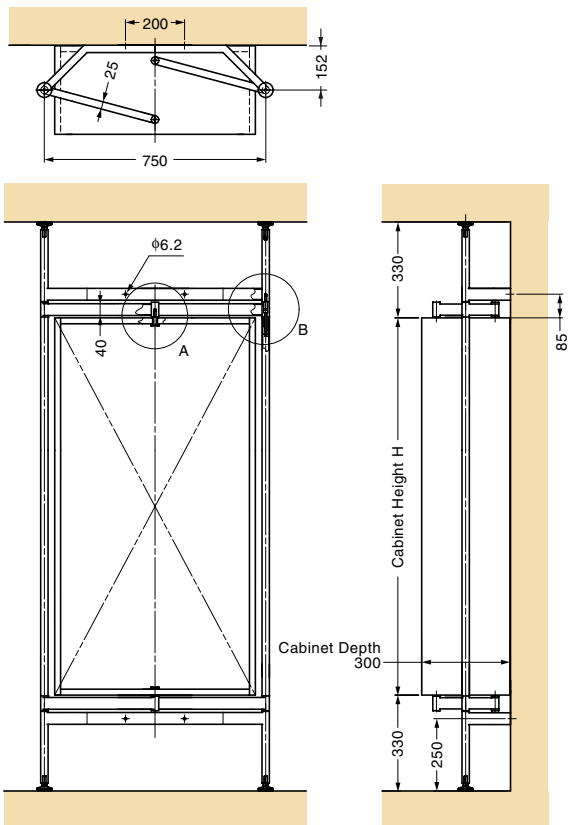

Close-up of A

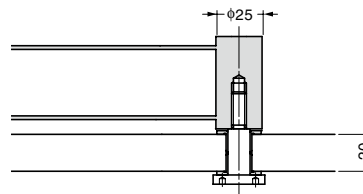

Close-up of B

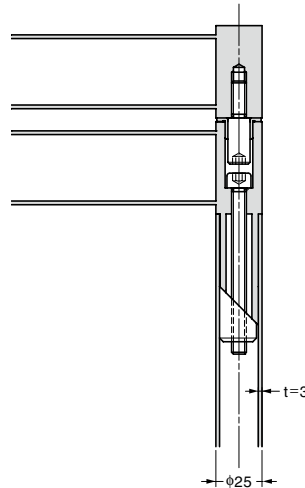

# TALLMAN CLOSET ROD LIFT MECHANISM

WARDROBE & CABINET DOOR HARDWARE

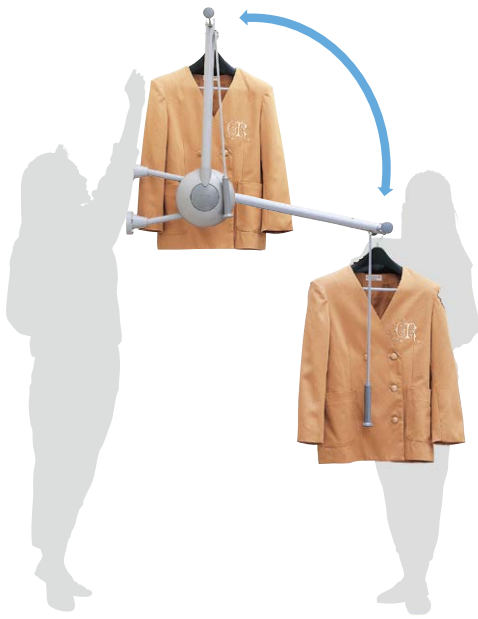

- Innovative closet storing mechanism to hang clothes in high places, allowing for your closet space to be utilized more efficiently.
- Equipped with a shock absorbing mechanism.
- Designed to soften sudden “pop-ups” even when rod is released halfway.
- Allows the closet rod to stay at position when the rod is pulled all the way down.

## Easy to Use



Easy to return the rod to normal position.

## Simple Installation



Install mounting plate on the wall, fasten rod unit to the mounting plate with one hidden screw.

## Size Variation



We offer single, double or T-type to accommodate your space requirements.

## Lower Hanging Pipe

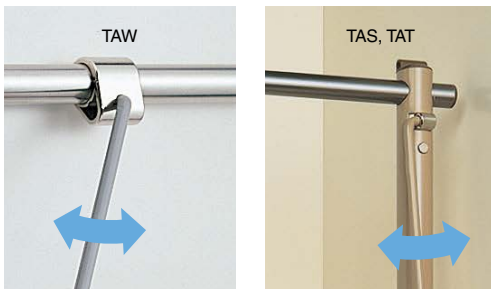

Flexible pull-down rod allows smooth operation.

TALLMAN CLOSET ROD LIFT MECHANISM

## CLOSET ROD LIFT MECHANISM (SINGLE TYPE)



TAS



### Features

- Single-type model for installation on a side wall of a cabinet or closet.
- Both right-handed and left-handed models available.

### Parts Included

Countersunk head wood screw 4.1x32

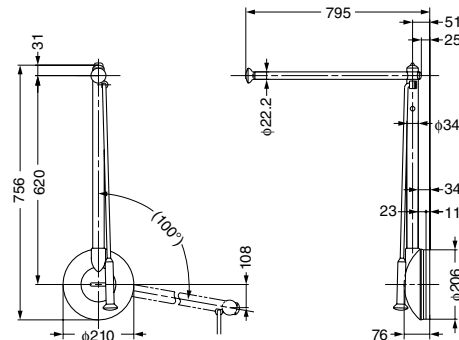
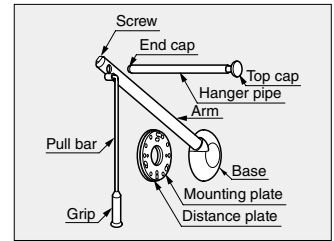

| Item Code   | Item Name  | Type       | Material               | Colour | Load Capacity |           | Weight | Box   | Carton |
|-------------|------------|------------|------------------------|--------|---------------|-----------|--------|-------|--------|
| 110-029-228 | TAS-800R-G | Right-Hand | Polystyrene (PS)/Steel | Grey   | 39.2 - 49 N   | 4 - 5 kgf | 6 kg   | 1 set | 3 sets |
| 110-029-229 | TAS-800L-G | Left-Hand  | Polystyrene (PS)/Steel | Grey   | 39.2 - 49 N   | 4 - 5 kgf | 6 kg   | 1 set | 3 sets |
| 110-029-230 | TAS-800R-U | Right-Hand | Polystyrene (PS)/Steel | Umber  | 39.2 - 49 N   | 4 - 5 kgf | 6 kg   | 1 set | 3 sets |
| 110-029-231 | TAS-800L-U | Left-Hand  | Polystyrene (PS)/Steel | Umber  | 39.2 - 49 N   | 4 - 5 kgf | 6 kg   | 1 set | 3 sets |

WARDROBE & CABINET DOOR HARDWARE

## CLOSET ROD LIFT MECHANISM (DOUBLE TYPE)



TAW



### Features

- Double-type model for installation on side walls of a cabinet or closet, using it in full width.
- Easy adjustment of rod length in just one step.

### Remarks

Not possible to cut the hanger pipe.

### Parts Included

Countersunk head wood screw 4.1x32

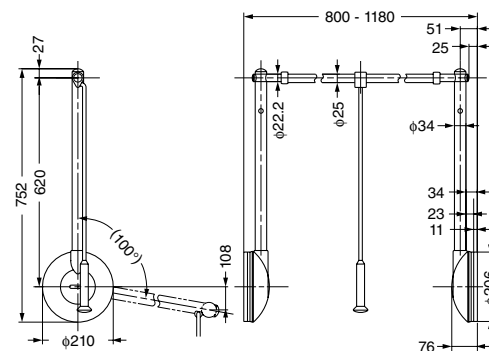
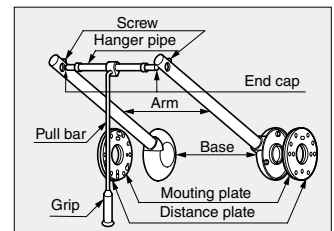

| Item Code   | Item Name  | Material               | Colour | Load Capacity |           | Weight | Box   | Carton |
|-------------|------------|------------------------|--------|---------------|-----------|--------|-------|--------|
| 110-029-001 | TAW-1200-G | Polystyrene (PS)/Steel | Grey   | 68.6 - 78.4 N | 7 - 8 kgf | 11 kg  | 1 set | 2 sets |
| 110-029-000 | TAW-1200-U | Polystyrene (PS)/Steel | Umber  | 68.6 - 78.4 N | 7 - 8 kgf | 11 kg  | 1 set | 2 sets |

TALLMAN CLOSET ROD LIFT MECHANISM

# CLOSET ROD LIFT MECHANISM (T-TYPE)



TAT



Bracket sold separately  
See below (TAB)

**Features**

- TAB, the bracket required for installation is sold separately.
- Create space more efficiently by separating short and long clothes.

**Parts Included**

Countersunk head wood screw 4.1x20

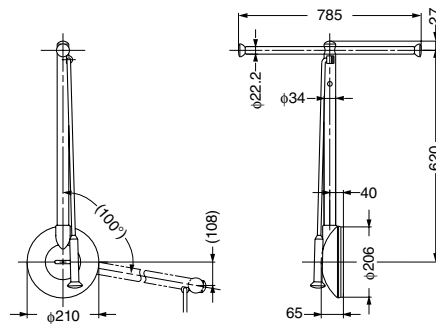
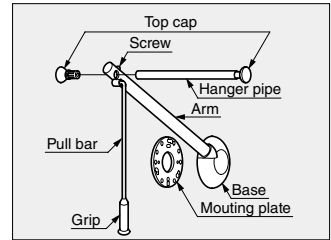

| Item Code   | Item Name  | Type       | Material               | Colour | Load Capacity |           | Weight | Box   | Carton |
|-------------|------------|------------|------------------------|--------|---------------|-----------|--------|-------|--------|
| 110-029-005 | TAT-800R-G | Right-Hand | Polystyrene (PS)/Steel | Grey   | 39.2 - 49 N   | 4 - 5 kgf | 6 kg   | 1 set | 3 sets |
| 110-029-004 | TAT-800L-G | Left-Hand  | Polystyrene (PS)/Steel | Grey   | 39.2 - 49 N   | 4 - 5 kgf | 6 kg   | 1 set | 3 sets |

# BRACKET



TAB

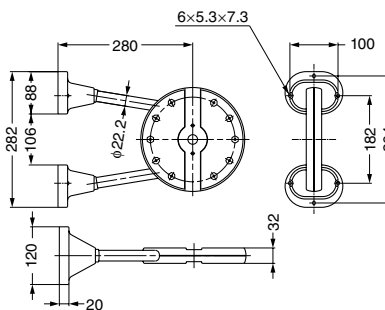

**Features**

Back wall mount bracket for TAS, TAW and TAT.

**Remarks**

Do not use impact driver.

**Parts Included**

- Wood screw 6 pcs
- Countersunk head screw 16 pcs

| Item Code   | Item Name | Material                   | Colour | Weight | Box  | Carton |
|-------------|-----------|----------------------------|--------|--------|------|--------|
| 110-020-170 | TAB-G     | Steel and Polystyrene (PS) | Grey   | 1.5 kg | 1 pc | 4 pcs  |
| 110-020-171 | TAB-U     | Steel and Polystyrene (PS) | Umber  | 1.5 kg | 1 pc | 4 pcs  |

# COVER FOR TAB BRACKET



TAC

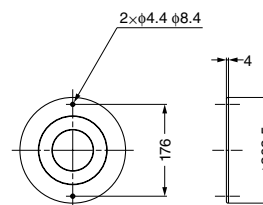

**Parts Included**

Countersunk head screw 2 pcs

| Item Code   | Item Name | Material | Colour | Weight  | Box  |
|-------------|-----------|----------|--------|---------|------|
| 110-020-176 | TAC-G     | Steel    | Grey   | 0.21 kg | 1 pc |
| 110-020-177 | TAC-U     | Steel    | Umber  | 0.21 kg | 1 pc |

LOWER HANGING PIPE

TAP, TAL

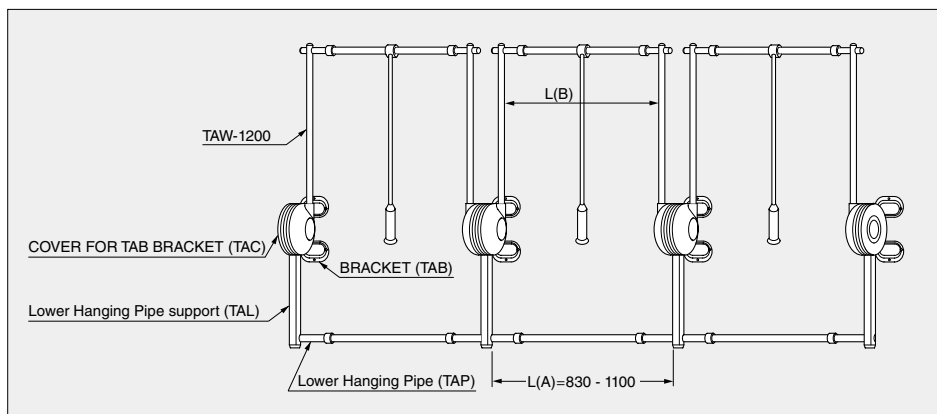

| Item Name                        | Qty. |
|----------------------------------|------|
| TAW-1200                         | 3    |
| BRACKET (TAB)                    | 4    |
| COVER FOR TAB BRACKET (TAC)      | 2    |
| Lower Hanging Pipe (TAP)         | 3    |
| Lower Hanging Pipe Support (TAL) | 4    |

Features

Allows to use the space under the unit more effectively.

Remarks

L(B) will be 120 mm shorter than L(A) in case using with TAW.

Parts Included

Wood screw 2 pcs

Lower Hanging Pipe (TAP)

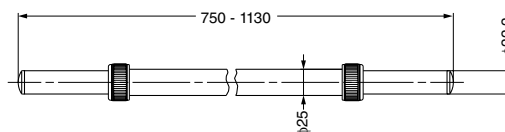

| Item Code   | Item Name  | Material            | Colour | Weight  | Box  |
|-------------|------------|---------------------|--------|---------|------|
| 110-020-184 | TAP-1200WG | Stainless Clad Pipe | Grey   | 0.85 kg | 1 pc |
| 110-020-185 | TAP-1200WU | Stainless Clad Pipe | Umber  | 0.85 kg | 1 pc |

Lower Hanging Pipe Support (TAL)

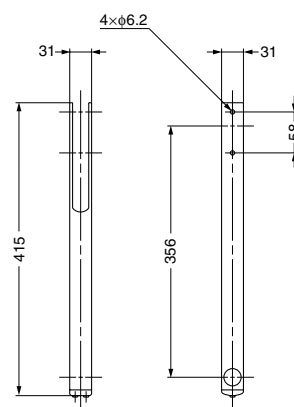

| Item Code   | Item Name | Material | Colour | Weight  | Box  |
|-------------|-----------|----------|--------|---------|------|
| 110-020-180 | TAL-G     | Steel    | Grey   | 0.42 kg | 1 pc |
| 110-020-181 | TAL-U     | Steel    | Umber  | 0.42 kg | 1 pc |

WARDROBE & CABINET DOOR HARDWARE

TALLMAN CLOSET ROD LIFT MECHANISM

## EXTENSION HANGER



WH

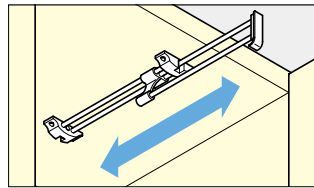
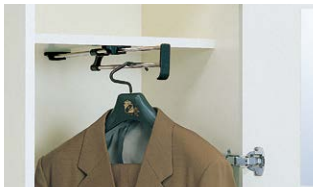
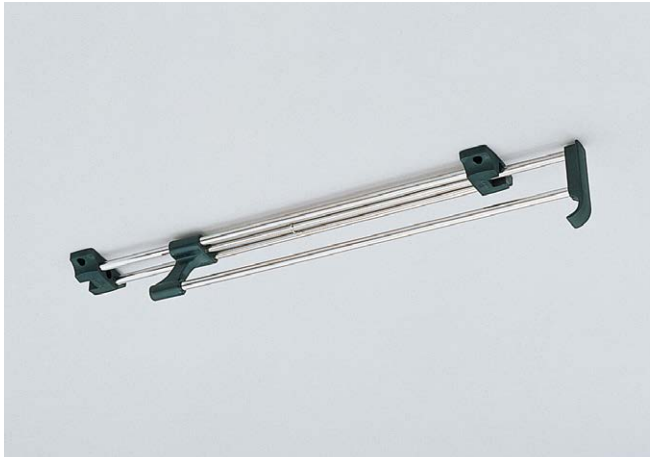

### Features

Space-saving, undermount design for narrow spaces.

### Parts Included

Pan head tapping screw 3.5x20

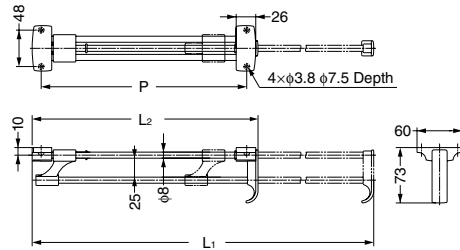

| Part Name      | Material       | Finish/Colour |
|----------------|----------------|---------------|
| Hanger Rod     | Steel          | Nickel        |
| Retainer Guide | Polyamide (PA) | Black         |

| Item Code   | Item Name | L <sub>1</sub> | L <sub>2</sub> | P   | Load Capacity |       | Weight | Box   | Carton |
|-------------|-----------|----------------|----------------|-----|---------------|-------|--------|-------|--------|
| 110-020-131 | WH-300    | 498            | 300            | 273 | 58.8 N        | 6 kgf | 485 g  | 5 pcs | 30 pcs |
| 110-020-132 | WH-350    | 570            | 350            | 323 | 49 N          | 5 kgf | 560 g  | 5 pcs | 30 pcs |
| 110-020-133 | WH-400    | 628            | 400            | 373 | 49 N          | 5 kgf | 630 g  | 5 pcs | 30 pcs |
| 110-020-134 | WH-450    | 698            | 450            | 423 | 39.2 N        | 4 kgf | 715 g  | 5 pcs | 30 pcs |

## EXTENSION HANGER



AS

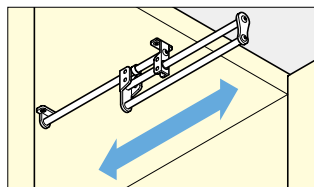

### Features

Space-saving, undermount design for narrow spaces.

### Parts Included

Raised countersunk head wood screw 3.5x25 (SUS)

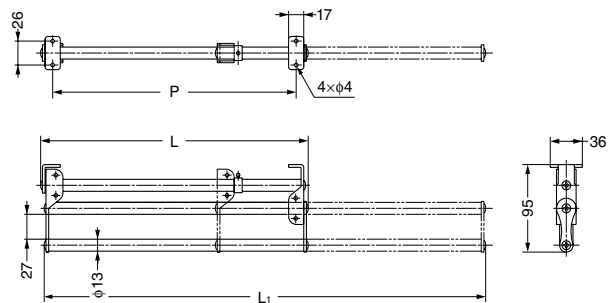

| Item Code   | Item Name | Material                 | Finish | L <sub>1</sub> | L   | P   | Load Capacity |       | Weight | Box   | Carton |
|-------------|-----------|--------------------------|--------|----------------|-----|-----|---------------|-------|--------|-------|--------|
| 110-020-138 | AS-300    | Stainless Steel (SUS430) | Satin  | 495            | 300 | 273 | 49 N          | 5 kgf | 395 g  | 5 pcs | 50 pcs |
| 110-020-139 | AS-330    | Stainless Steel (SUS430) | Satin  | 545            | 330 | 303 | 49 N          | 5 kgf | 420 g  | 5 pcs | 50 pcs |
| 110-020-140 | AS-360    | Stainless Steel (SUS430) | Satin  | 598            | 360 | 333 | 49 N          | 5 kgf | 405 g  | 5 pcs | 50 pcs |
| 110-020-141 | AS-400    | Stainless Steel (SUS430) | Satin  | 665            | 400 | 373 | 49 N          | 5 kgf | 440 g  | 5 pcs | 50 pcs |

# EXTENSION HANGER



UH



### Features

Space-saving, undermount design for narrow spaces.

### Parts Included

Tapping screw 4x25 (SUS)

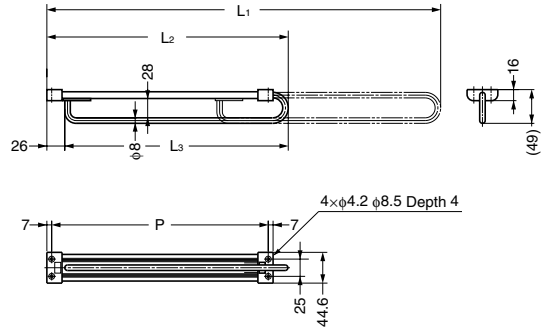

| Part Name    | Material                 | Finish/Colour |
|--------------|--------------------------|---------------|
| End Cap      | Polyamide (PA)           | Black         |
| Guide Block  | Polyethylene (PE)        | Black         |
| Hanger Rod   | Stainless Steel (SUS304) | Satin         |
| Rod Retainer | Steel                    | Chrome        |

| Item Code   | Item Name | L <sub>1</sub> | L <sub>2</sub> | L <sub>3</sub> | P   | Load Capacity |       | Weight | Box   | Carton |
|-------------|-----------|----------------|----------------|----------------|-----|---------------|-------|--------|-------|--------|
| 110-021-045 | UH-300    | 491            | 300            | 274            | 264 | 29.4 N        | 3 kgf | 365 g  | 5 pcs | 30 pcs |
| 110-021-046 | UH-350    | 571            | 350            | 324            | 314 | 29.4 N        | 3 kgf | 440 g  | 5 pcs | 30 pcs |
| 110-021-047 | UH-400    | 636            | 400            | 374            | 364 | 29.4 N        | 3 kgf | 505 g  | 5 pcs | 30 pcs |
| 110-021-048 | UH-450    | 721            | 450            | 424            | 414 | 29.4 N        | 3 kgf | 570 g  | 5 pcs | 30 pcs |

# EXTENSION HANGER



TE700, TE800



### Features

- Space-saving, undermount design for narrow, deep spaces.
- Ideal for wardrobe and large storage furniture which have a deep depth.
- 200 mm rear support can be adjusted for shorter/longer spaces.

### Remarks

Cabinet depth : TE700 (Min. 700 mm), TE800 (Min. 800 mm).

### Parts Included

Round head wood screws 4.5x20

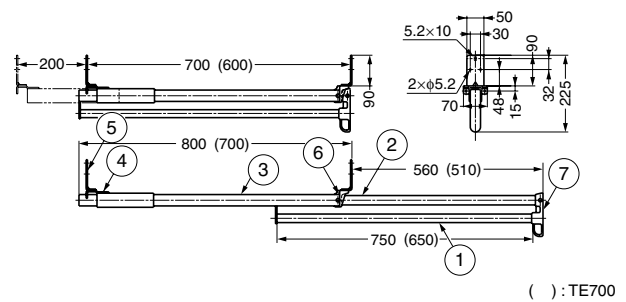

( ) : TE700

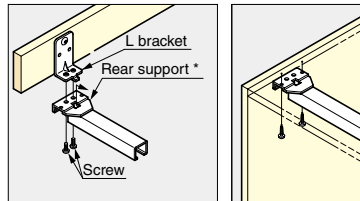
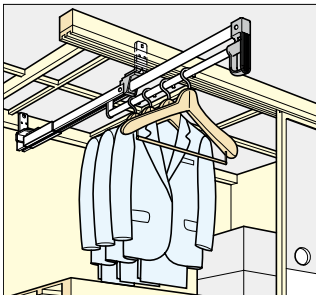

\* Use L bracket (included) for side-mount.

| No. | Part Name    | Material | Finish/Colour |
|-----|--------------|----------|---------------|
| ①   | Hanger Pipe  | Steel    | Chrome        |
| ②   | Sliding Rail | Steel    | Chrome        |
| ③   | Fix Rail     | Steel    | Metalic Brown |
| ④   | Rear Support | Steel    | Metalic Brown |
| ⑤   | L Bracket    | Steel    | Metalic Brown |
| ⑥   | Guide Cap    | Plastic  | Black         |
| ⑦   | Knob         | Plastic  | Black         |

| Item Code   | Item Name | Length | Travel Length | Depth Dimension | Load Capacity |        | Weight | Box  | Carton |
|-------------|-----------|--------|---------------|-----------------|---------------|--------|--------|------|--------|
| 110-020-147 | TE-700    | 700    | 520           | 600 - 800       | 196 N         | 20 kgf | 2.4 kg | 1 pc | 6 pcs  |
| 110-020-148 | TE-800    | 800    | 570           | 700 - 900       | 196 N         | 20 kgf | 2.7 kg | 1 pc | 6 pcs  |

# HEAVY DUTY EXTENSION HANGER

TEST METHOD 5



SH740



### Features

- Space-saving, undermount design for narrow spaces.
- Drawer slide allows smooth movement.
- Back mounting bracket can be adjusted for shorter /longer spaces (70 mm).

### Parts Included

Round head wood screws 4.5x20

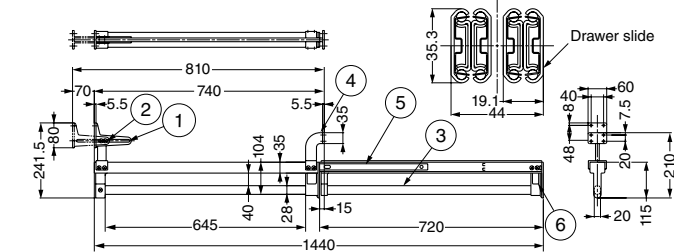
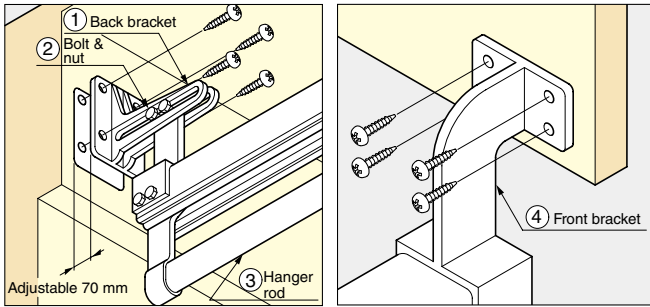

| No. | Part Name     | Material | Finish |
|-----|---------------|----------|--------|
| ①   | Back Bracket  | Brass    | Chrome |
| ②   | Bolt-Nut      | Steel    | Chrome |
| ③   | Hanger Rod    | Steel    | Chrome |
| ④   | Front Bracket | Brass    | Chrome |
| ⑤   | Drawer Slide  | Steel    | Chrome |
| ⑥   | Knob          | Brass    | Chrome |

| Item Code   | Item Name | Length    | Load Capacity    | Weight | Box  | Carton |
|-------------|-----------|-----------|------------------|--------|------|--------|
| 110-020-146 | SH740     | 740 - 810 | 401.8 N / 41 kgf | 6.1 kg | 1 pc | 2 pcs  |

# HANGER BRACKET

TEST METHOD 4



CK



### Features

Light duty hanger brackets for garments, umbrellas, etc.

### Parts Included

Truss tapping screw 4x20

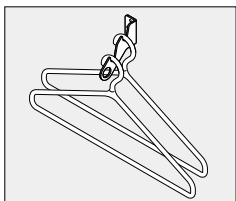

CK-60L

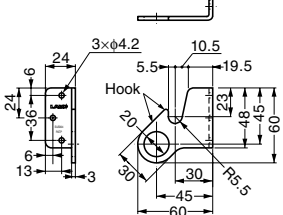

CK-90L

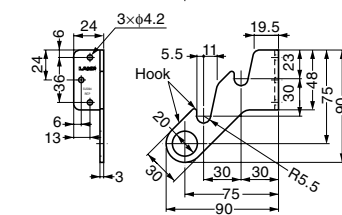

CK-120L

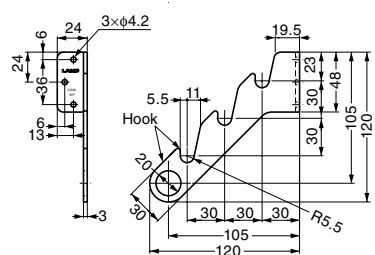

| Item Code   | Item Name | Material                 | Finish | Load Capacity/position | Weight | Box    | Carton  |
|-------------|-----------|--------------------------|--------|------------------------|--------|--------|---------|
| 110-020-260 | CK- 60L   | Stainless Steel (SUS304) | Satin  | 14.7 N / 1.5 kgf       | 66 g   | 15 pcs | 150 pcs |
| 110-020-261 | CK- 90L   | Stainless Steel (SUS304) | Satin  | 14.7 N / 1.5 kgf       | 90 g   | 15 pcs | 150 pcs |
| 110-020-262 | CK-120L   | Stainless Steel (SUS304) | Satin  | 14.7 N / 1.5 kgf       | 113 g  | 10 pcs | 100 pcs |

WARDROBE & CABINET DOOR HARDWARE

EXTENSION HANGER / HANGER BRACKET



## SWINGING HANGER

TEST METHOD 4

STAINLESS 304 STEEL

STAINLESS

## HM-250V

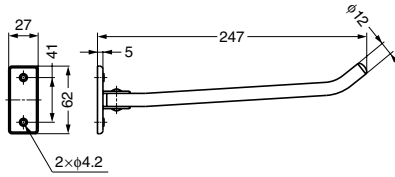

### Parts Included

Raised countersunk head wood screw 3.5x20 (SUS)

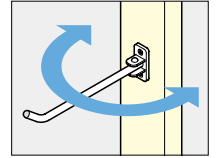

| Item Code   | Item Name | Material                      | Finish | Load Capacity | Weight | Box   | Carton |
|-------------|-----------|-------------------------------|--------|---------------|--------|-------|--------|
| 110-020-086 | HM-250V   | Stainless Steel (SUS304)/EPDM | Satin  | 29.4 N        | 3 kgf  | 120 g | 10 pcs |

## SWINGING HANGER

TEST METHOD 4

STAINLESS 304 STEEL

STAINLESS

## HM-250Y

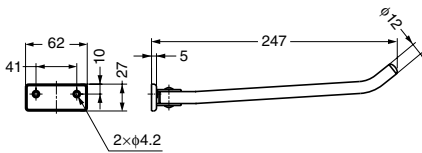

### Parts Included

Raised countersunk head wood screw 3.5x20 (SUS)

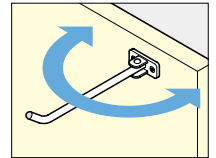

| Item Code   | Item Name | Material                      | Finish | Load Capacity | Weight | Box   | Carton |
|-------------|-----------|-------------------------------|--------|---------------|--------|-------|--------|
| 110-020-088 | HM-250Y   | Stainless Steel (SUS304)/EPDM | Satin  | 29.4 N        | 3 kgf  | 136 g | 10 pcs |

## SWINGING HANGER

TEST METHOD 4

STAINLESS 304 STEEL

STAINLESS

## HM-330

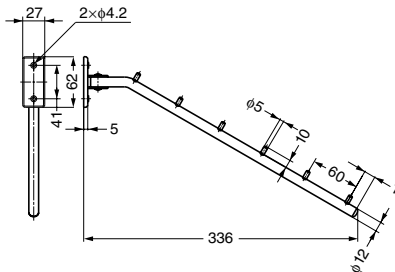

### Parts Included

Raised countersunk head wood screw 3.5x20 (SUS)

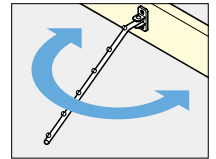

| Item Code   | Item Name | Material                      | Finish | Load Capacity | Weight | Box   | Carton |
|-------------|-----------|-------------------------------|--------|---------------|--------|-------|--------|
| 110-020-089 | HM-330    | Stainless Steel (SUS304)/EPDM | Satin  | 29.4 N        | 3 kgf  | 190 g | 10 pcs |

## PLASTIC SOCKET

## PS-37

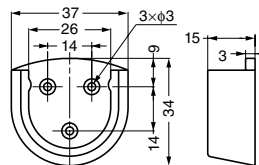

### Features

Ideal for holding pipes in wardrobes.

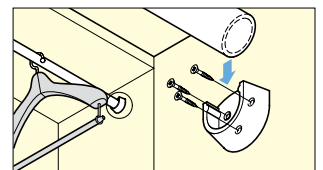

| Item Code   | Item Name | Material    | Colour | Load Capacity | Weight       | Box | Carton  |
|-------------|-----------|-------------|--------|---------------|--------------|-----|---------|
| 110-030-118 | PS-37     | Polystyrene | White  | 196 N/2 pcs   | 20 kgf/2 pcs | 8 g | 100 pcs |

WARDROBE & CABINET DOOR HARDWARE

SWINGING HANGER / PLASTIC SOCKET

TIE RACK

TIEM

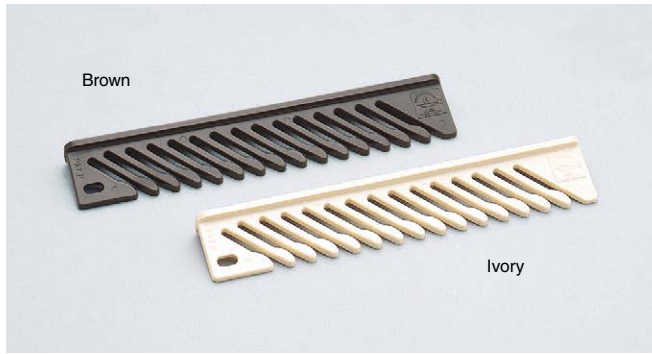

Remarks  
Screws not included.

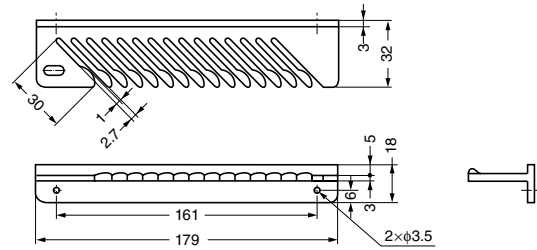

Application Example

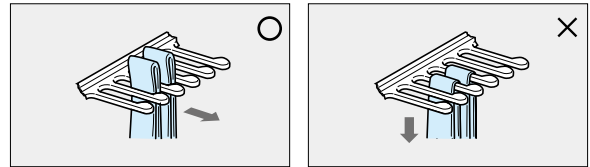
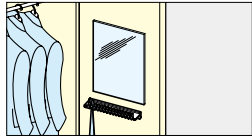

| Item Code   | Item Name | Material           | Colour | Load Capacity/position | Weight  | Box  | Carton |         |
|-------------|-----------|--------------------|--------|------------------------|---------|------|--------|---------|
| 110-020-124 | TIEM-BR   | Polycarbonate (PC) | Brown  | 2.94 N                 | 0.3 kgf | 22 g | 20 pcs | 400 pcs |
| 110-020-125 | TIEM-I    | Polycarbonate (PC) | Ivory  | 2.94 N                 | 0.3 kgf | 22 g | 20 pcs | 400 pcs |

WARDROBE & CABINET DOOR HARDWARE

TIE RACK

TIE RACK

TIE-33

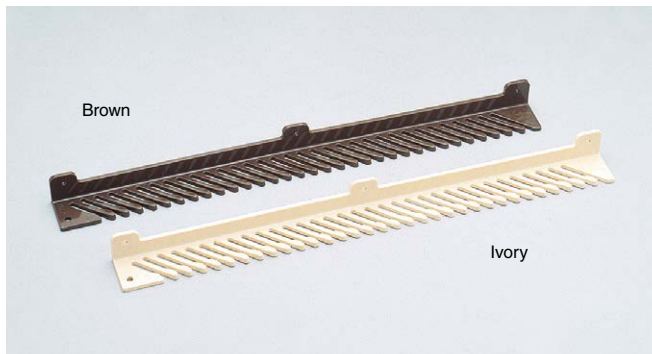

Parts Included  
Wood screws

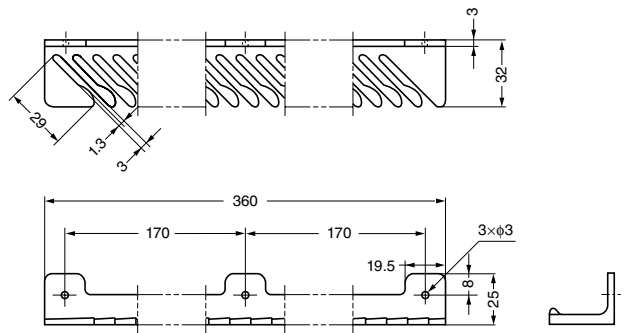

Application Example

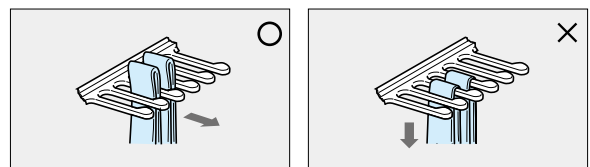

| Item Code   | Item Name | Material           | Colour | Load Capacity/position | Weight  | Box  | Carton |         |
|-------------|-----------|--------------------|--------|------------------------|---------|------|--------|---------|
| 110-020-126 | TIE-33BR  | Polycarbonate (PC) | Brown  | 2.94 N                 | 0.3 kgf | 50 g | 20 pcs | 300 pcs |
| 110-020-127 | TIE-33I   | Polycarbonate (PC) | Ivory  | 2.94 N                 | 0.3 kgf | 50 g | 20 pcs | 300 pcs |

TIE RACK



MST-20

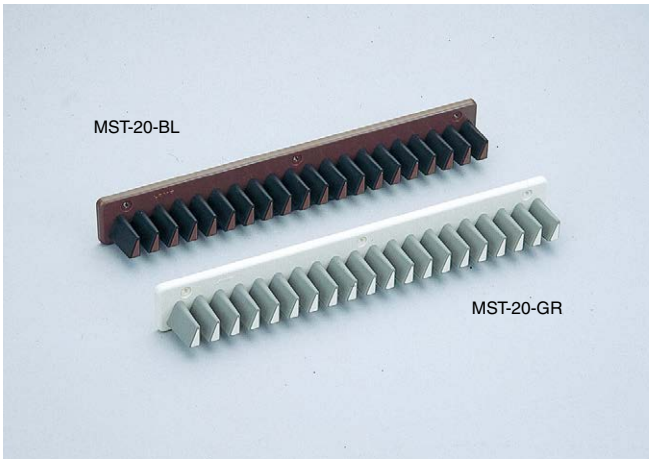

Features

2 ways of holding possible depending on tie thickness.

Parts Included

Binding head tapping screw 4 × 14 (SUS)

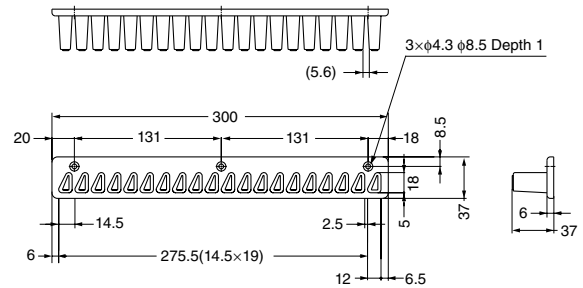

Application Example



| Part Name | Material        |
|-----------|-----------------|
| Body      | ABS             |
| Stopper   | Elastomer (TPE) |

| Item Code   | Item Name | Colour      | Load Capacity/position | Weight  | Box   | Carton           |
|-------------|-----------|-------------|------------------------|---------|-------|------------------|
| 110-025-304 | MST-20BL  | Brown+Black | 2.94 N                 | 0.3 kgf | 116 g | 10 pcs / 120 pcs |
| 110-025-305 | MST-20GR  | Ivory+Grey  | 2.94 N                 | 0.3 kgf | 116 g | 10 pcs / 120 pcs |

TIE RACK



TR



Features

Holding bar keeps the ties tidy.

Parts Included

Round head wood screw 3.1 × 16

How to Use

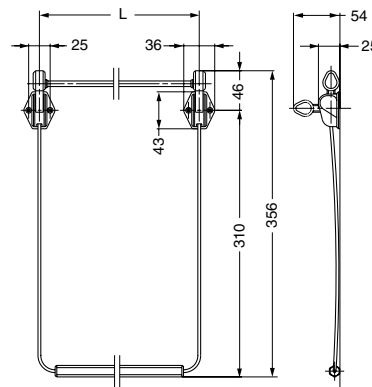
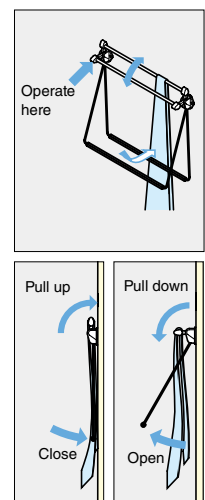

| Item Code   | Item Name | Material                                  | Colour/Finish | L   | Weight | Box    | Carton |
|-------------|-----------|---|---------------|-----|--------|--------|--------|
| 110-020-110 | TR-300    | Polyamide (PA) and Polyacetal (POM)/Steel | Brown/Chrome  | 300 | 190 g  | 10 pcs | 80 pcs |
| 110-020-111 | TR-350    | Polyamide (PA) and Polyacetal (POM)/Steel | Brown/Chrome  | 350 | 210 g  | 10 pcs | 80 pcs |
| 110-020-112 | TR-400    | Polyamide (PA) and Polyacetal (POM)/Steel | Brown/Chrome  | 400 | 243 g  | 10 pcs | 80 pcs |

\*Limited stock available Please contact your vendor.



# TIE RACK



S-350

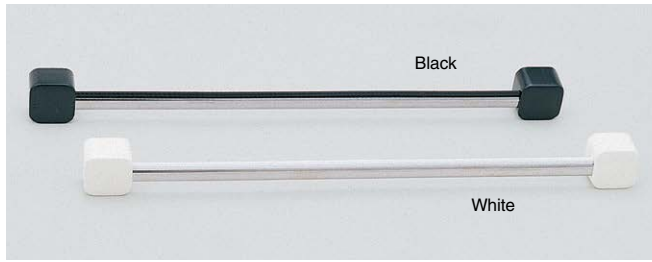

### Parts Included

- Truss head tapping screw 3 × 16

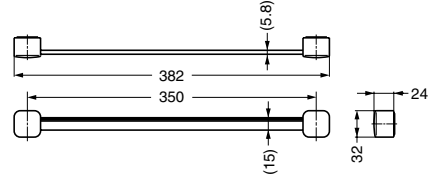

| Item Code   | Item Name | Material                     | Colour/Finish  | Weight | Box    | Carton  |
|-------------|-----------|------------------------------|----------------|--------|--------|---------|
| 110-020-118 | S-350W    | ABS/Stainless Steel (SUS304) | White/Polished | 80 g   | 10 pcs | 100 pcs |
| 110-020-119 | S-350B    | ABS/Stainless Steel (SUS304) | Black/Polished | 80 g   | 10 pcs | 100 pcs |

# TIE RACK



STR



### Parts Included

- Round head wood screw 3.1 × 16 (Chromate)
- Countersunk head screw M3 × 8 (Chrome)

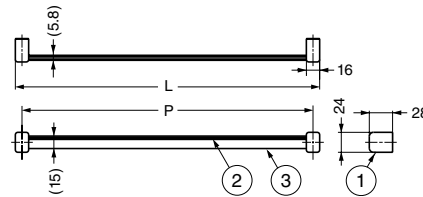

### Installation

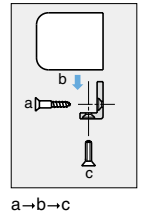

| Item Code   | Item Name | L   | P   | Weight | Box    | Carton |
|-------------|-----------|-----|-----|--------|--------|--------|
| 110-020-244 | STR-300   | 316 | 300 | 160 g  | 10 pcs | 60 pcs |
| 110-020-245 | STR-350   | 366 | 350 | 170 g  | 10 pcs | 60 pcs |
| 110-020-246 | STR-400   | 416 | 400 | 180 g  | 10 pcs | 60 pcs |
| 110-020-153 | STR-450   | 466 | 450 | 190 g  | 10 pcs | 60 pcs |

| No. | Material                   | Finish/Colour |
|-----|----------------------------|---------------|
| ①   | Zinc Alloy (ZDC)           | Chrome        |
| ②   | Vinyl Chloride Resin (PVC) | Black         |
| ③   | Stainless Steel (SUS304)   | Mirror        |

# TIE RACK



DTR



### Parts Included

- Round head wood screw 3.1 × 16 (Chromate)
- Countersunk head screw M3 × 8 (Chrome)

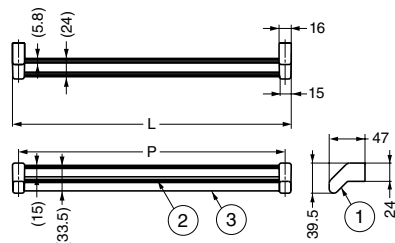

### Installation

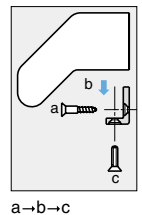

| Item Code   | Item Name | L   | P   | Weight | Box   | Carton |
|-------------|-----------|-----|-----|--------|-------|--------|
| 110-020-154 | DTR-350   | 366 | 350 | 250 g  | 5 pcs | 30 pcs |
| 110-020-155 | DTR-400   | 416 | 400 | 270 g  | 5 pcs | 30 pcs |
| 110-020-156 | DTR-450   | 466 | 450 | 285 g  | 5 pcs | 30 pcs |

| No. | Material                   | Finish/Colour |
|-----|----------------------------|---------------|
| ①   | Zinc Alloy (ZDC)           | Chrome        |
| ②   | Vinyl Chloride Resin (PVC) | Black         |
| ③   | Stainless Steel (SUS304)   | Mirror        |